

# Online Split-Phase Identification of Asymmetric Parameters Between Distribution Lines and Ground for Unbalanced Voltage Compensation Based on Power Electronics

Moufa Guo <sup>ORCID</sup>, *Member, IEEE*, Yaohui Jiao <sup>ORCID</sup>, Zeyin Zheng <sup>ORCID</sup>, *Member, IEEE*, Binlong Zhang <sup>ORCID</sup>, *Student Member, IEEE*, Jiahao Lin <sup>ORCID</sup>, *Student Member, IEEE*, and Qiteng Hong <sup>ORCID</sup>, *Senior Member, IEEE*

**Abstract**—Most of the phase-to-ground parameters induced between distribution lines and ground are asymmetric, which can result in the generation of unbalanced voltage, shifting the neutral point voltage. For compensated distribution networks, the existence of an arc suppression coil can increase the influence of asymmetric parameters and exacerbate the deviation of neutral point voltage. Maintaining the balance of three-phase voltage is a prerequisite not only for the stable operation of the distribution networks but also for improving the reliability of single-phase ground fault detection. This article proposes a novel online split-phase identification of asymmetric parameters between distribution lines and ground for unbalanced voltage compensation based on power electronics. First, an adaptive active current-type compensation method based on power electronics is proposed; it can adapt to compensate for three-phase unbalanced voltage with different neutral point grounding styles. Second, particle swarm optimization is used to realize the online split-phase identification of the phase-to-ground parameters of the distribution power lines. The identified parameters are used to calculate the reference value of the compensation current and the asymmetry of each phase-to-ground parameter. Finally, the feasibility and effectiveness of the proposed method are verified by simulation and experiment.

**Index Terms**—Asymmetric parameters, distribution networks, online parameter split-phase identification, particle swarm optimization (PSO), power electronics, unbalanced voltage compensation.

Manuscript received 15 December 2023; revised 5 March 2024; accepted 27 April 2024. Date of publication 2 May 2024; date of current version 20 June 2024. This work was supported in part by the National Natural Science Foundation of China under Award 51677030 and in part by the Natural Science Foundation of Fujian Province, China, under Award 2023J05106. Recommended for publication by Associate Editor S. Golestan. (*Corresponding author: Zeyin Zheng.*)

Moufa Guo, Yaohui Jiao, Zeyin Zheng, Binlong Zhang, and Jiahao Lin are with the College of Electrical Engineering and Automation, Fuzhou University, Fujian 350116, China, and also with the Engineering Research Center of Smart Distribution Grid Equipment, Fujian Province University, Fuzhou 350108, China (e-mail: gmf@fzu.edu.cn; 210120040@fzu.edu.cn; zhengzeyin@fzu.edu.cn; 220110011@fzu.edu.cn; 210110009@fzu.edu.cn).

Qiteng Hong is with the Department of Electronic and Electrical Engineering, University of Strathclyde, G1 1RD Glasgow, U.K. (e-mail: q.hong@strath.ac.uk).

Color versions of one or more figures in this article are available at <https://doi.org/10.1109/TPEL.2024.3396216>.

Digital Object Identifier 10.1109/TPEL.2024.3396216

## I. INTRODUCTION

THE single-phase ground (SPG) fault is the most common fault in distribution networks. According to statistics, 70% of faults that occurred in distribution networks were SPG faults, which may be accompanied by arc, leading to bushfire, electrocution, widespread power outages, etc., [1], [2]. The main component of SPG fault current is capacitive current, which is caused by the distribution line-ground capacitance. Although capacitance between individual phases also exists, it does not interact with the SPG fault current, so it is ignored. Paul [3] used the symmetrical component theory to conduct a detailed analysis of the SPG fault current. Moreover, the author explained the current flow direction and vector relationship of SPG fault current in different grounding methods of distribution networks through vector diagrams. Most countries use arc suppression coils (ASC) to compensate for SPG fault current, which is highly efficient [4], [5]. However, with the penetration of a great number of power electronics in distribution networks, the proportion of SPG fault current components has changed [6]. The proportion of harmonic and resistive components has increased, which results in traditional ASC being unable to meet the SPG fault current limiting requirements. To ensure the lowest possible SPG fault current, active compensation devices (ACD) have a more efficient performance, which is composed of an automatically tuned ASC and a residual current compensation device based on power electronics [7]. Its working principle is that when SPG faults occur, ASC compensates for the majority of the capacitive current, and the residual current compensation device compensates for the remaining component of the fault current. As one of the promising solutions to reduce SPG fault current, it has received increasing attention in distribution networks.

With the increasing demand for electricity quality from people, the key requirements for ACD mainly include two aspects. First, ACD must fully compensate for the capacitive component of SPG fault current during operation, i.e., fully tuned. This is to limit the amplitude of the fault current to the maximum extent possible, thereby ensuring the minimum energy to be released during the SPG faults. Second, the premise for complete tuning of ACD is that the three-phase-to-ground parameters are

symmetrical. This is essentially to avoid generating resonant overvoltage. Therefore, it is necessary to alleviate the asymmetry of three-phase-to-ground parameters between distribution lines and the ground.

Actually, most of the phase-to-ground parameters induced between distribution lines and ground are asymmetric [8]. It can be attributed to various factors such as the unbalanced operation of the distribution networks, overhead lines being installed without phase rotation, and uneven placement of voltage transformers or compensating capacitors [9], [10]. These factors are inevitable. Traditional methods for compensating the unbalanced voltage caused by the asymmetry of three-phase-to-ground parameters of the distribution networks can generally be categorized into two approaches. The first approach involves adding a damping resistor in series with the branch of the ASC to compensate for the asymmetry degree of phase-to-ground parameters, increasing the system damping ratio and ensuring that the unbalanced degree of three-phase voltage remains within the permitted range [11], [12]. The second approach involves adding power capacitors to the distribution lines to reduce the asymmetry of three-phase-to-ground parameters of the distribution networks, thereby compensating for the unbalanced three-phase voltage [13]. However, these two methods are highly passive and do not adapt well to the changes in the three-phase-to-ground parameters of the distribution networks. That can limit the speed and accuracy of compensating for the three-phase unbalanced voltage. More importantly, these measures tend to increase the level of fault current, which is prohibited in some situations, such as bushfire mitigation. Therefore, alleviating the asymmetry of three-phase-to-ground parameters between distribution lines and the ground is a problem worth studying.

According to recent research, ACD and dynamic voltage regulators (DVR) are effective methods to compensate for three-phase unbalanced voltage in the distribution networks. The DVR is connected in series with the power lines through a step-up transformer. It can inject three single-phase output voltages with controllable amplitude, phase, and frequency to compensate for unbalanced voltage [14]. However, for a 10-kV distribution network, DVR requires cascading more inverters to improve its withstand voltage level, which means its cost is higher. In addition, the short-circuit impedance of series transformers reduces the voltage accuracy of open-loop control and affects the performance of the device. The transformer also has problems such as saturation and inrush current. The ACD is connected to the neutral point of the distribution network, which compensates for unbalanced voltage by injecting controllable current [15]. However, DVR and ACD need to work continuously to compensate for the unbalanced voltage caused by the asymmetry of phase-to-ground parameters, which greatly reduces the service life of the device. Wang et al. [16] used mathematical methods to demonstrate the existence of an optimal injection current, which is used to compensate for the asymmetry of the phase-to-ground parameters. A certain amount of current is injected through the compensation device, the amplitude remains constant and the phase is continuously varied. The neutral point voltage is used as feedback. The phase of the current is optimal when the neutral voltage is at its minimum value and then kept constant to find the optimal current amplitude. Finally, this current is injected

through the compensation device to achieve compensation for the unbalanced voltage.

The measure of compensating for unbalanced voltage by improving the asymmetry of three-phase-to-ground parameters has not been truly resolved. There are not many existing methods for studying the asymmetry of three-phase-to-ground parameters. Most of them assume that the phase-to-ground parameters in per-phase are known, or are calculated based on power line parameters [17], [18]. However, this method is not feasible for complex distribution lines. Gargoom et al. [19] proposed a new equivalent circuit diagram for distribution networks with asymmetric ground parameters and calculated the asymmetry of each phase-to-ground parameter based on the admittance matrix operation. It needs to establish an accurate shunt admittance sequence matrix and does not adapt to dynamic changes in ground parameters.

Based on the above issues, this article proposes an online split-phase identification of asymmetric parameters between distribution lines and ground for unbalanced voltage compensation based on a cascaded H-bridge converter. The main contributions and innovations are summarized as follows.

- 1) A new calculation for the reference current is proposed that can be applied to different grounding methods of the neutral point of the distribution networks, which enables effective compensation for three-phase unbalanced voltage caused by the asymmetry of phase-to-ground parameters.
- 2) The online split-phase identification scheme of phase-to-ground parameters in the distribution networks is provided and developed. This approach addresses the challenges of high measurement cost, low measurement accuracy, and the inability to measure individual phase-to-ground parameters by traditional methods. The identified parameters can bring other benefits, such as the expansion of the arcing coil, the calculation of the asymmetry of the distribution network, etc.
- 3) The proposed scheme integrates the compensation of three-phase unbalanced voltage with the measurement of the phase-to-ground parameters in the distribution networks. It aims to minimize the neutral point voltage by adjusting the compensation current, thereby evaluating the effectiveness of parameter identification.

The rest of this article is organized as follows. The principle of three-phase voltage imbalance compensation in distribution networks is introduced in Section II. The principle of particle swarm optimization (PSO) and the phase-to-ground parameters identification based on PSO are presented in Section III. The implementation strategy of the proposed method is described in Section IV. In Section V, simulation and experimental results are provided. Finally, Section VI concludes this article.

## II. PRINCIPLE OF ASYMMETRIC COMPENSATION METHOD OF PHASE-TO-GROUND PARAMETERS IN DISTRIBUTION NETWORKS

### A. Structure of the Neutral Point Connected With an Active Compensation Device

There are existing two structures for ACD to connect to the distribution network, which are a neutral point connection type

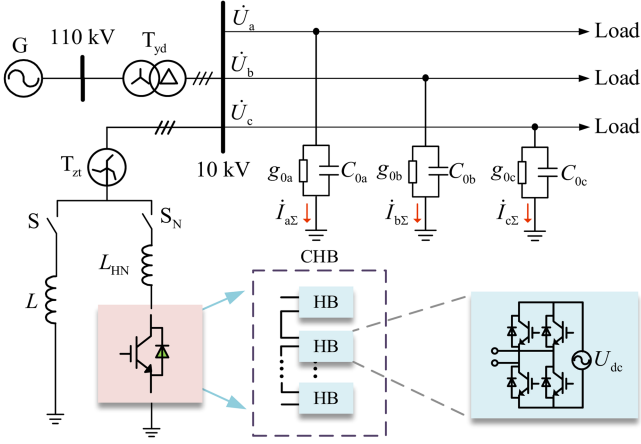

Fig. 1. Structure of the neutral point connected with the active compensation device.

and a three-phase busbar direct-mounted type. Of which, the neutral point connection type has advantages such as low cost and high equipment utilization. Therefore, this article adopts the structure of a neutral point connected with ACD, which injects current into the distribution networks to compensate for the three-phase unbalanced voltage caused by the asymmetry of phase-to-ground parameters.

The connection structure of the ACD to the neutral point of the distribution network is shown in Fig. 1, where G represents the ac grid.  $T_{yd}$  and  $T_{zt}$  represent a 110 kV/10.5 kV transformer and a grounding transformer, and  $\dot{U}_X$  ( $X = a, b, c$ ) and  $\dot{U}_0$  are the phase-ground voltage and the neutral point voltage (zero-sequence voltage), respectively. The phase-ground leakage resistances are  $g_{0a}$ ,  $g_{0b}$ , and  $g_{0c}$ , respectively. The phase-ground capacitances are  $C_{0a}$ ,  $C_{0b}$ , and  $C_{0c}$ , respectively.  $L_{HN}$  and  $L$  indicate the filter inductor and the ASC, respectively. S and  $S_N$  represent the single-phase breaker. The ACD consists of several H-bridges in series and a filter inductor together, and its dc-side voltage is denoted by  $U_{dc}$ .

During the normal operation of the distribution networks, the ACD is used as a reactive power compensation device, which adjusts the power factor to maintain the stability of the distribution networks. During the stage of compensating for neutral point voltage, ACD is used as a current source, which injects current into the distribution network to compensate for the three-phase unbalanced voltage caused by the asymmetry of phase-to-ground parameters.

### B. Strategy of Three-Phase Unbalanced Voltage Compensation for Distribution Networks

As shown in Fig. 1, when the distribution network is operating normally, it can be deduced from Kirchhoff's current law that

$$\begin{aligned} & (\dot{E}_a + \dot{U}_0)(j\omega C_{0a} + g_{0a}) + (\dot{E}_b + \dot{U}_0)(j\omega C_{0b} + g_{0b}) \\ & + (\dot{E}_c + \dot{U}_0)(j\omega C_{0c} + g_{0c}) + \dot{U}_0 Y_L = 0 \end{aligned} \quad (1)$$

where  $Y_L$  is an admittance of the ASC.

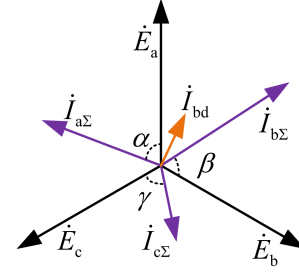

Fig. 2. Current relationship diagram.

If the system voltage is symmetrical, the relationship between each phase-to-ground voltage can be expressed as

$$\begin{cases} \dot{E}_a = V_{am} \angle 0^\circ = V_{am} \\ \dot{E}_b = V_{am} \angle -120^\circ = \alpha^2 V_{am} \\ \dot{E}_c = V_{am} \angle 120^\circ = \alpha V_{am} \end{cases} \quad (2)$$

where  $V_{am}$  is the amplitude of the phase-to-ground voltage and  $\alpha = e^{j120^\circ}$ .

Submitting (2) into (1), the neutral point voltage  $\dot{U}_0$  can be expressed as

$$\begin{aligned} \dot{U}_0 &= -(\dot{E}_a Y_a + \dot{E}_b Y_b + \dot{E}_c Y_c) / (Y_a + Y_b + Y_c + Y_L) \\ &= -\dot{E}_a (Y_a + \alpha^2 Y_b + \alpha Y_c) / (Y_a + Y_b + Y_c + Y_L) \end{aligned} \quad (3)$$

where the admittances  $Y_X = g_{0X} + j\omega C_{0X}$ ,  $X = a, b, c$ . In (3), if the ground parameter is symmetrical, then  $\dot{U}_0$  is zero.

The current relationship diagram of the grounding system is shown in Fig. 2, where  $\alpha$ ,  $\beta$ , and  $\gamma$  are the admittance angles of the three-phase-to-ground parameters, respectively. They are close to  $90^\circ$  because the power lines-to-ground capacitance is much greater than the line-to-ground conduction.  $\dot{I}_{X\Sigma} = \dot{E}_X Y_X$  represent the line-to-ground leakage current. If the asymmetry of the system power supply potential is ignored and three-phase-to-ground parameters are asymmetric,  $\dot{I}_{X\Sigma}$  are asymmetric, and its vector sum is a natural unbalanced current  $\dot{I}_{bd} = \dot{E}_a (Y_a + \alpha^2 Y_b + \alpha Y_c)$ . Therefore, the three-phase unbalanced voltage is

$$\dot{U}_{bd} = -\dot{I}_{bd} / (Y_a + Y_b + Y_c + Y_L). \quad (4)$$

Similarly, the expression for the neutral point voltage in the case of ungrounded neutral points can be derived as

$$\dot{U}_{bd} = -\dot{I}_{bd} / (Y_a + Y_b + Y_c). \quad (5)$$

Comparing (4) and (5), it can be observed that the presence of ASC greatly increases  $\dot{U}_{bd}$ . To compensate for  $\dot{U}_{bd}$  during the normal operation of the distribution networks, this article adopts ACD to inject current into the distribution networks. When  $S_N$  is closed, the injection current is rewritten as

$$\begin{aligned} \dot{I}_z &= (\dot{E}_a + \dot{U}_0)(j\omega C_{0a} + g_{0a}) + (\dot{E}_b + \dot{U}_0)(j\omega C_{0b} + g_{0b}) \\ &+ (\dot{E}_c + \dot{U}_0)(j\omega C_{0c} + g_{0c}) + \dot{U}_0 Y_L. \end{aligned} \quad (6)$$

Replacing (4) with (6), the three-phase unbalanced voltage can be restated as

$$\begin{aligned}\dot{U}_{bd} &= \dot{I}_z - (\dot{E}_a Y_a + \dot{E}_b Y_b + \dot{E}_c Y_c) / (Y_a + Y_b + Y_c + Y_L) \\ &= \dot{I}_z - \dot{I}_{bd} / Y_a + Y_b + Y_c + Y_L.\end{aligned}\quad (7)$$

Obviously, when  $\dot{U}_{bd}$  is zero, the reference current value  $\dot{I}_z$  needs to

$$\dot{I}_z = \dot{E}_a Y_a + \dot{E}_b Y_b + \dot{E}_c Y_c. \quad (8)$$

The existing active current-type compensation methods have different calculation methods for the current reference value of distribution networks under different neutral point grounding styles. In a resonant grounded system, the calculation of the injected current reference value also requires the equivalent inductance value of the ASC [15]. The proposed method can adapt to compensate for three-phase unbalanced voltage with different neutral point grounding styles. For the active voltage-type compensation method, it takes the neutral voltage as the control target and controls the neutral voltage to zero. Additionally, it has an impact on fault detection and the action of electrical protection devices. It is not recommended to compensate for a three-phase unbalanced voltage.

It is worth noticing that the calculation of  $\dot{I}_z$  in the proposed method requires phase-to-ground parameters of each phase in the distribution networks. Currently, most of the measurement methods for phase-to-ground parameters in distribution networks focus on measuring the overall phase-to-ground parameters. Therefore, the split-phase identification scheme of phase-to-ground parameters in the distribution networks is provided in the following sections.

### III. PRINCIPLE OF SPLIT-PHASE IDENTIFICATION BASED ON PSO FOR PHASE-TO-GROUND PARAMETERS IN DISTRIBUTION NETWORKS

#### A. Principle of PSO

The PSO was proposed by Eberhart and Kennedy in 1995. It has been extensively applied to various global optimization problems [20], [21]. In [22], the position and other parameters of the permanent magnet are identified by the PSO, thereby achieving fault diagnosis of permanent magnet synchronous motors. In [23], PSO is used to identify fuel cell parameters and establish a fuel cell model suitable for engineering purposes. In [24], PSO is used to estimate the electrical and mechanical parameters of permanent magnet motor drives, laying the foundation for building the model. The updated formula for speed and position can be expressed as

$$\begin{aligned}v_i(t+1) &= \omega v_i(t) + c_1 r_1 (p_i(t) - x_i(t)) \\ &\quad + c_2 r_2 (p_{gj}(t) - x_i(t)) \\ x_i(t+1) &= x_i(t) + v_i(t+1).\end{aligned}\quad (9)$$

The specific movement process of the particle is shown in Fig. 3, where  $p_i$  denotes the individual best position and  $p_{gi}$  denotes the global best position.

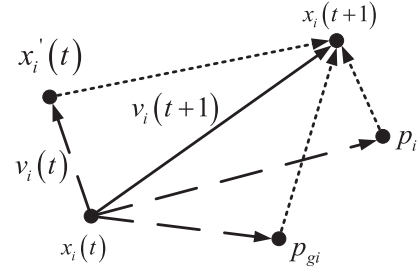

Fig. 3. Schematic of particle movement.

The direction of particle velocity at the next moment is determined by the current inertia direction, individual optimal direction, and group optimal direction. The particle continuously updates its position through velocity until the algorithm ends.

#### B. Principle of the Split-phase Identification Phase-to-Ground Parameters Based on PSO

The method proposed injects current to compensate for three-phase unbalanced voltages caused by phase-to-ground parameter asymmetry in distribution networks. The reference value of the injection current is determined by individual phase-to-ground parameters. However, traditional measurement methods for phase-to-ground parameters are unable to identify each phase-to-ground parameter. To address this issue, a split-phase identification of the three-phase-to-ground parameters method based on PSO is proposed. This study combines the parameter optimization algorithm with the measurement of phase-to-ground parameters in distribution networks. Taking the neutral point voltage to zero as the goal, the relationship between the phase-to-ground parameters of distribution networks and the injection current is constructed. By changing the reference value of the injected current of ACD and observing the suppressed neutral displacement voltage, the effectiveness of parameter identification can be determined. The specific steps are described in the following sections.

1) *Model*: To achieve reliable online identification of phase-to-ground parameters, a reasonable model of the distribution network is constructed. Since the influence of the phase-to-ground leakage resistance on three-phase unbalanced voltage can be neglected, the model is depicted in Fig. 4. Where  $\dot{I}_H$  is the output current of the ACD,  $C_a$ ,  $C_b$ , and  $C_c$  represent individual phase-to-ground parameters during the algorithm iteration, they change their own size according to (9).  $\dot{I}_X = \dot{E}_X C_{0X}$  represents the line-to-ground leakage current.

2) *Coordinated Control*: As shown in Fig. 4, the control objective of ACD is its output branch current  $i_H$ , whose reference value is  $i_z$ , which can be calculated using (8). The purpose is to counteract the neutral unbalanced current  $\dot{I}_{bd}$ , thereby limiting the neutral point voltage. However, the key to calculating the reference current value is to obtain accurate three-phase-to-ground voltages  $e_X$ , which cannot be measured directly. To accurately extract  $e_X$ , the proposed method uses a second-order generalized integral and a phase-locked loop [25]. After the reference current values  $i_z$  is calculated by (8), a proportional-integral

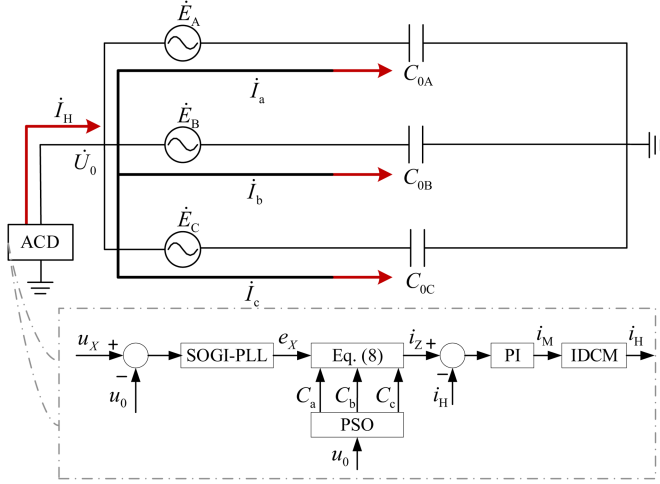

Fig. 4. Asymmetrical structure of phase-to-ground parameters of the distribution network.

(PI) controller is used to regulate the output current  $i_H$  of the ACD.  $i_M$  represents a modulation signal, which converts the output current through modulation strategy improved distributed commutation modulation (IDCM).

3) *Adaptation function*: When  $S_N$  is closed,  $\dot{I}_z$  can be expressed as

$$\dot{I}_z = \dot{E}_a C_{0a} + \dot{E}_b C_{0b} + \dot{E}_c C_{0c} + \dot{U}_0 (C_{0a} + C_{0b} + C_{0c} + Y_L). \quad (10)$$

When the inductance of the ASC in a resonant grounded system is unknown, there are four unknowns in (10). For mathematical methods, it is not possible to directly calculate unknowns, so most methods measure the sum of phase-to-ground parameters, such as the three-frequency method [26], secondary injection method [27], and resonance measurement method [28]. The PSO is used to identify the phase-to-ground parameters. It can continuously change the iteration direction and speed based on the feedback to reach the termination condition, and then get the parameters we need. More importantly, it enables online identification of phase-to-ground parameters. Furthermore, the phase-to-ground capacitance of the distribution network is unknown, which makes it difficult to assess the quality of the identification results. It is further proposed that the magnitude of the neutral voltage can be used as an indirect criterion for parameter identification results. Equation (10) can be transformed as follows:

$$\begin{aligned} \dot{U}_0 &= \frac{\dot{I}_z - (\dot{E}_a C_{0a} + \dot{E}_b C_{0b} + \dot{E}_c C_{0c})}{C_{0a} + C_{0b} + C_{0c} + Y_L} \\ \dot{I}_z &= \dot{E}_a C_a + \dot{E}_b C_b + \dot{E}_c C_c \end{aligned} \quad (11)$$

where the reference current value  $\dot{I}_z$  changes with  $C_a$ ,  $C_b$ , and  $C_c$ . When  $\dot{U}_0$  is close to zero, it indicates that the identified parameters at this point are close to the true values, i.e.,  $C_a$ ,  $C_b$ , and  $C_c$  are closed to  $C_{0a}$ ,  $C_{0b}$ , and  $C_{0c}$ .

4) *Algorithm parameters*: The parameter identification process of this algorithm requires setting certain parameters within

the algorithm itself. These parameters include the particle size, particle dimensions, and inertia weight, among others. The particle size of the PSO is set to 8 and the inertia weight  $\omega$  is set to 0.8. The particle dimensions in this study correspond to the number of parameters to be identified, which is 3. The initial values of the particles are set to one-third of the total phase-to-ground capacitance. To prevent large neutral point voltage caused by injecting incorrect current, this algorithm imposes constraints on  $\dot{U}_0$ . In the proposed method, a voltage limit of 1000 V (in China, the long-term working voltage of the neutral point voltage under normal operating conditions should not exceed 15% of the rated phase-to-ground voltage) is set for  $\dot{U}_0$ . The voltage limit represents the maximum value of  $\dot{U}_0$  caused by injecting different zero-sequence currents during the iterative process. Once  $\dot{U}_0$  exceeds the limit, the parameter value is skipped, and the previous parameter values are used to continue the iteration.

PSO is used to realize the online split-phase identification of the phase-to-ground parameters of the distribution power lines can solve problems that traditional mathematical methods can not solve through optimization. In addition, PSO can be programmed into ACD. Phase-to-ground parameters can be identified once within a certain period, which can adapt to the dynamic changes of distribution lines. More importantly, the proposed method does not require human involvement, which can reduce measurement errors.

#### IV. IMPLEMENTATION STRATEGY OF THE PROPOSED METHOD

In this article, the research focuses on the split-phase identification of three-phase-to-ground parameters of the distribution network and the compensation of the unbalanced voltage caused by the asymmetric phase-to-ground parameters. During the normal operation of the distribution networks, the identification of three-phase-to-ground parameters is realized by the idea of PSO. Subsequently, the identified parameters are used to calculate a reference value for the injected current, which is then injected through the ACD to compensate for the three-phase unbalanced voltage. This method can not only identify the capacitance of each phase-to-ground but also maintain the balance of three-phase voltage. The flowchart of the proposed strategy is shown in Fig. 5.

First, the parameters of the algorithm are initialized, and a set of root mean squares (RMS) of zero-sequence voltage  $\dot{U}_0^{\text{RMS}}$  is constructed, which is used to store  $\dot{U}_0^{\text{RMS}}$  corresponding to different particles. Second, the level signal is generated through the pulse generator. At the rising or falling edge of the level,  $\dot{U}_0^{\text{RMS}}$  caused by the particle compare with the value of the corresponding voltage in the set of  $\dot{U}_0^{\text{RMS}}$ . Once  $\dot{U}_0^{\text{RMS}}$  is smaller than the corresponding voltage in the set of  $\dot{U}_0^{\text{RMS}}$ ,  $\dot{U}_0^{\text{RMS}}$  is updated in the set of  $\dot{U}_0^{\text{RMS}}$ , and phase-to-ground parameters are recorded and stored at this time, and vice versa. When a group of eight particles is judged, the optimal parameters and the minimum  $\dot{U}_0^{\text{RMS}}$  within the group are recorded and stored. With the iteration of the algorithm, the optimal parameters and the minimum  $\dot{U}_0^{\text{RMS}}$  are continuously updated until the algorithm is terminated. The last updated optimal parameters are the ones closest to the real value. It should be noted that the proposed

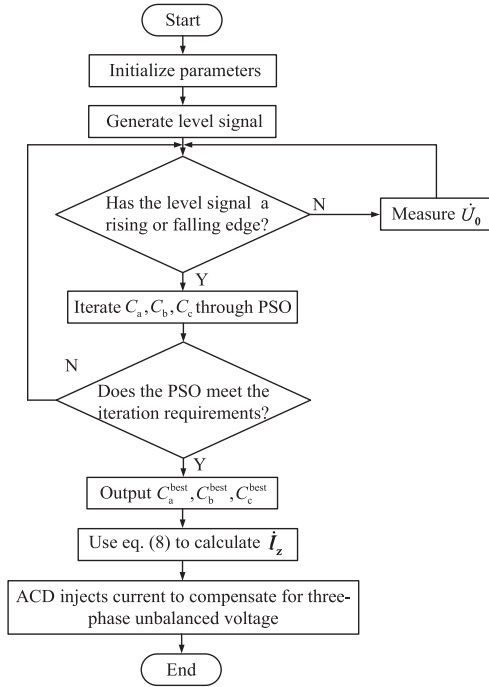

Fig. 5. Flowchart of the proposed strategy.

method is an online parameter identification of the distribution networks. It cannot be like traditional PSO that generates several particles to search for the optimal value parallelly. It only serially searches for the optimal value. Algorithms generate a group of phase-to-ground parameters, and the corresponding compensation current is injected into the distribution networks and  $\dot{U}_0^{\text{RMS}}$  is collected. After a group of 8 particles has all obtained corresponding  $\dot{U}_0^{\text{RMS}}$  in turn, each particle is iterated according to the speed formula until the algorithm stops. When  $\dot{U}_{\text{bd}}$  exceeds a certain threshold, ASD injects current into the distribution networks to compensate for the three-phase unbalanced voltage.

Compared with other traditional measurement methods, this method can achieve online identification of each phase-to-ground parameter, reducing errors caused by human operation and measurement calculation. Second, for power lines with frequent parameter changes, ACD can be used to compensate for the unbalanced voltage caused by the asymmetry of three-phase-to-ground parameters. For power lines with infrequent parameter changes, the asymmetry of each phase can be calculated by identifying the parameters. The asymmetry of the three-phase-to-ground parameters can be permanently compensated through parallel capacitors, which can reduce device action time and increase device service life. More importantly, when SPG faults occur, ACD can inject the current calculated from the identified parameters to suppress the fault current.

## V. SIMULATION AND EXPERIMENTAL RESULTS

### A. Simulation Results

To verify the feasibility and effectiveness of the proposed method, a simulation model of the distribution network based

TABLE I  
SIMULATION PARAMETERS

Parameters	Value
Single phase-to-ground leakage resistance	10 k $\Omega$
A-phase-to-ground capacitance	6 $\mu\text{F}$
B-phase-to-ground capacitance	7 $\mu\text{F}$
C-phase-to-ground capacitance	8 $\mu\text{F}$
Switching frequency	10 kHz
Filter inductance	70 mH
DC-link voltage of each HB	90 V

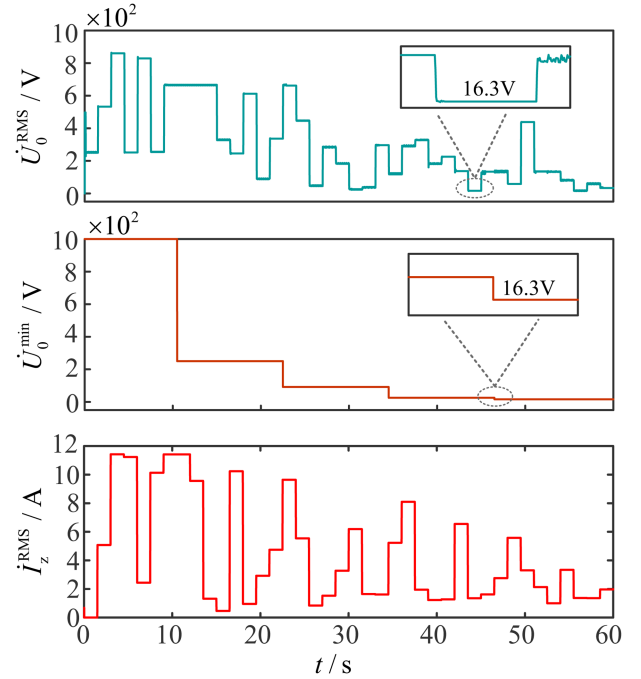

Fig. 6. Iteration process of RMS zero-sequence voltage and the minimum of zero-sequence voltage.

on a cascaded H-bridge converter is built using Matlab/Simulink software. The simulation parameters are shown in Table I.

To validate the effectiveness of the split-phase identification method for phase-to-ground parameters based on the PSO, the iteration of  $\dot{U}_0^{\text{RMS}}$ ,  $\dot{U}_0^{\text{min}}$  and the variations in target parameters during the PSO iterations are depicted in Figs. 6 and 7, respectively, where  $\dot{U}_0^{\text{min}}$  represents the minimum  $\dot{U}_0^{\text{RMS}}$ .  $C_a^{\text{best}}$ ,  $C_b^{\text{best}}$ , and  $C_c^{\text{best}}$  represent the optimization parameters for phase A, phase B, and phase C respectively.  $\dot{I}_z^{\text{RMS}}$  represents the RMS of injected current.  $\dot{U}_0$  serves as an indicator of the quality of the identification results and the direction of particle velocity. In Fig. 6, it can be observed that  $\dot{U}_0^{\text{min}}$  occurs from 43.5 to 45 s, which is 16.3 V. It indicates that the identified phase-ground capacitance value is closest to the true value at this moment. As the parameters iterate and update,  $\dot{U}_0^{\text{min}}$  becomes progressively smaller. It can be observed that at 46.5 s,  $\dot{U}_0^{\text{min}}$  reaches its minimum value. Comparing with  $\dot{U}_0^{\text{RMS}}$ , the reason for this discrepancy is that  $\dot{U}_0^{\text{RMS}}$  is recorded and stored with a delay

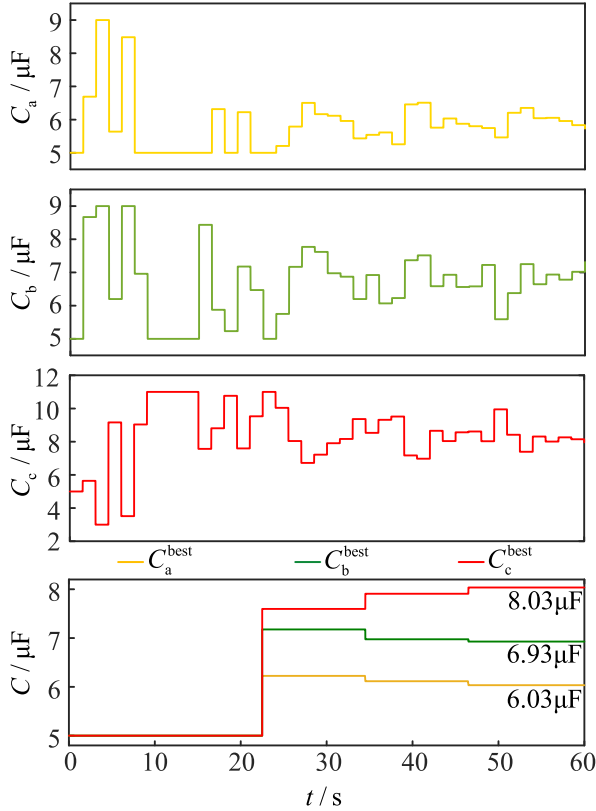

Fig. 7. Iteration process of each phase-to-ground capacitance and the optimal capacitances.

of one cycle, which is 3 s. At this moment, it indicates that the identified phase-to-ground capacitances of the distribution network are closest to the true values, which are recorded and stored.

Since the capacitance values cannot change abruptly to prevent the generation of a large inrush current, the parameter values are set to change every 1.5 s. The initial value of  $C_a$ ,  $C_b$ , and  $C_c$  are set to 5  $\mu\text{F}$ . Then the values of them are continuously updated as the algorithm iterates. In addition, it is an online parameter identification of the distribution networks, the particles can only be changed serially, that is one particle corresponds to the reference value of the injected current. After injecting current into the distribution networks through the ASD and collecting  $\dot{U}_0$ . Then, the same operation is performed on the next particle. Therefore, each group of particles requires a duration of 12 s, i.e., the optimal particles are updated every 12 s.

In Fig. 7, from 43.5 to 45 s,  $C_a^{\text{best}}$ ,  $C_b^{\text{best}}$ , and  $C_c^{\text{best}}$  are the closest to the real values. The accuracy rate of the identified results (phase A, phase B, phase C) is as high as 99.1%, 99.1%, and 99.9%, respectively. The accuracy rate is defined as the ratio of identified results to the real values.

Figs. 8 and 9 verify the effectiveness of compensating the three-phase unbalanced voltage in the distribution networks. The reference value of compensation current is calculated by identifying parameters and injected into the distribution network through ACD.  $\dot{U}_a$ ,  $\dot{U}_b$ , and  $\dot{U}_c$  represent the phase A voltage, phase B voltage, and phase C voltage, respectively. In Fig. 8,

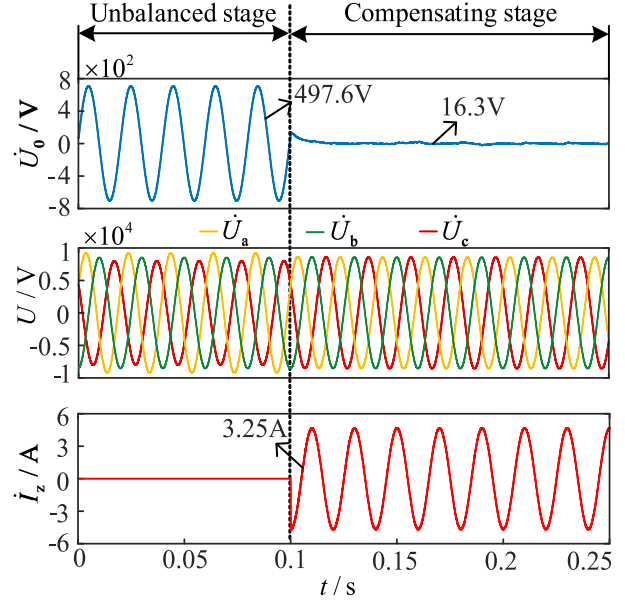

Fig. 8. Waveforms of compensation three-phase unbalanced voltage under neutral point ungrounded.

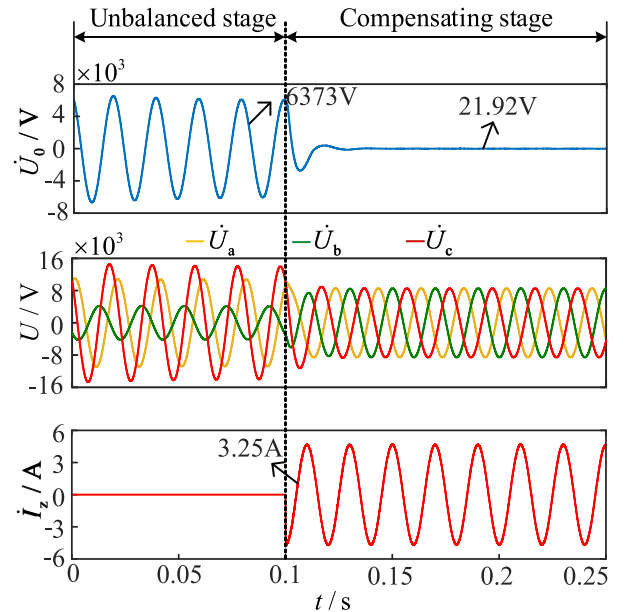

Fig. 9. Waveforms of compensation three-phase unbalanced voltage under neutral point grounded through arc suppression coil.

within the first 0.1 s, the unbalanced stage of the distribution network is caused by the asymmetry of the phase-to-ground parameters.  $\dot{U}_0^{\text{RMS}}$  is 497.6 V. At 0.1 s, ACD injects current to compensate for the three-phase unbalanced voltage. During the stage of the compensation stabilization,  $\dot{U}_0^{\text{RMS}}$  becomes 16.3 V, resulting in a compensation rate of 96.6%. The compensation rate is defined as the ratio of the reduction in the neutral point voltage to the original value. Clearly, the three-phase unbalanced voltage is effectively compensated.

Different from the case of Fig. 8, Fig. 9 represents the grounding of the neutral point in the distribution networks through the ASC. The presence of the ASC exacerbates the unbalanced

TABLE II  
SIMULATION RESULTS UNDER NEUTRAL POINT UNGROUNDED

$K\%$	$C_{0a}$ / $\mu\text{F}$	$C_{0b}$ / $\mu\text{F}$	$C_{0c}$ / $\mu\text{F}$	$\dot{U}_0$ /V	$C_a$ / $\mu\text{F}$	$C_b$ / $\mu\text{F}$	$C_c$ / $\mu\text{F}$	$\dot{U}_0^{\text{com}}$ /V
2.2	7.2	7.1	6.7	133.2	7.18	7.01	6.78	16.07
4.4	7.2	7.4	6.4	263.9	7.18	7.38	6.44	9.32
6.3	7.2	7.64	6.16	377.6	7.22	7.63	6.15	9.59
8.2	6	7	8	497.6	6.03	6.93	8.03	16.3

TABLE III  
SIMULATION RESULTS UNDER NEUTRAL POINT GROUNDED THROUGH ARC SUPPRESSION COIL

$K\%$	$C_{0a}$ / $\mu\text{F}$	$C_{0b}$ / $\mu\text{F}$	$C_{0c}$ / $\mu\text{F}$	$\dot{U}_0$ /V	$C_a$ / $\mu\text{F}$	$C_b$ / $\mu\text{F}$	$C_c$ / $\mu\text{F}$	$\dot{U}_0^{\text{com}}$ /V
2.2	7.2	7.1	6.7	1646	7.15	7.13	6.71	19.14
4.4	7.2	7.4	6.4	3324	7.19	7.44	6.37	11.16
6.3	7.2	7.64	6.16	4812	7.21	7.64	6.14	7.23
8.2	6	7	8	6373	6.01	6.96	8.04	21.92

voltage caused by the asymmetry in phase-to-ground parameters. During the unbalanced stage,  $\dot{U}_0^{\text{RMS}}$  reaches up to 6373 V. However, after injecting the compensation current,  $\dot{U}_0^{\text{RMS}}$  reduces to 21.92 V, resulting in a suppression rate of 99.66%.

In Tables II and III, the three-phase-asymmetry coefficient is expressed as  $K\% = |(C_{0a} + \alpha^2 C_{0b} + \alpha C_{0c}) / (C_{0a} + C_{0b} + C_{0c})| \times 100$ .  $\dot{U}_0^{\text{com}}$  represents compensated neutral point voltage. It can be observed that the impact of grounding parameter asymmetry in distribution networks varies depending on the neutral point grounding configuration. After the ACD injects a certain compensating current, the three-phase voltage imbalance caused by the asymmetry of phase-to-ground parameters is effectively compensated. It is worth mentioning that the proposed method can adapt to compensate for three-phase unbalanced voltage with different neutral point grounding styles.

### B. Experimental Results

To verify further the feasibility of the proposed method, experiments were conducted on a physical simulation system of a distribution network. The physical simulation system has a line-to-line voltage of 380 V. It includes six feeders, and the line model uses an equivalent  $\pi$  model, as shown in Fig. 10.

The physical prototype of the ACD is shown in Fig. 11. The ACD consists of six H-bridge modules connected in cascade, the head end of which is connected to the neutral point of the Z-type transformer at the busbar through a filter inductor and a switch, the tail end is directly earthed. The dc side power supply of this device is obtained from a bus voltage of 380 V through a three-phase adjustable transformer, a three-phase multiwinding isolation transformer, and a three-phase uncontrolled rectifier bridge. The experimental parameters are listed in Table IV.

Figs. 12–17 show the experimental results of parameter identification and unbalanced voltage compensation under different

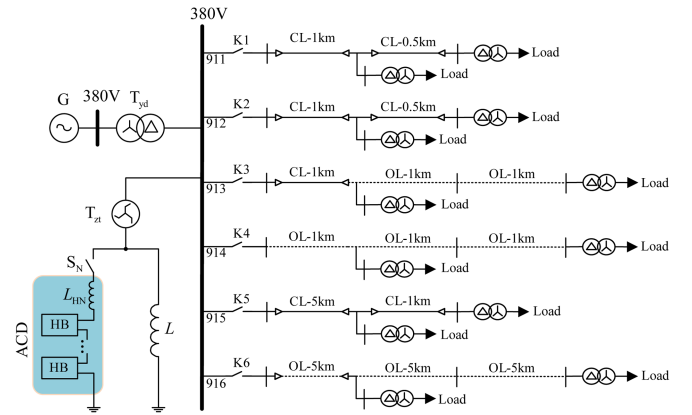

Fig. 10. Single-line diagram of the experimental setup.



Fig. 11. Experimental platform and ACD physical prototype.

neutral point grounding styles. The first 20 s is the parameter identification stage. ACD is equivalent to a controlled current source. As the algorithm iterates, the individual parameters are constantly updated. From 20 to 25 s, ACD is equivalent to a constant current source. The identified parameters are used to calculate the reference value of the injected current, which is modulated and controlled. Then the ACD outputs a stable current to compensate for the three-phase unbalanced voltage.

From Figs. 12 and 15, when the convergence condition is reached,  $\dot{U}_0^{\text{RMS}}$  reaches its minimum value, and the corresponding  $\dot{U}_0^{\text{min}}$  also reaches its minimum value after a delay of 1.5 s. The algorithm has identified the optimum parameters and stored them at this time. The accuracy of recognition results is high, which meets the requirements of the distribution network.

As shown in Figs. 14 and 17, in the parameter identification stage, the parameters are constantly updated, which in turn

TABLE IV  
 EXPERIMENTAL PARAMETERS

Parameters	Value
Sample frequency	6 kHz
Switching frequency	5 kHz
Filter inductance	100 mH
Number of H-bridges in CHB	6
DC-link voltage of each HB	20 V
DC-link capacitor of HB	4700 $\mu\text{F}$
Single phase-to-ground leakage resistance	10 k $\Omega$

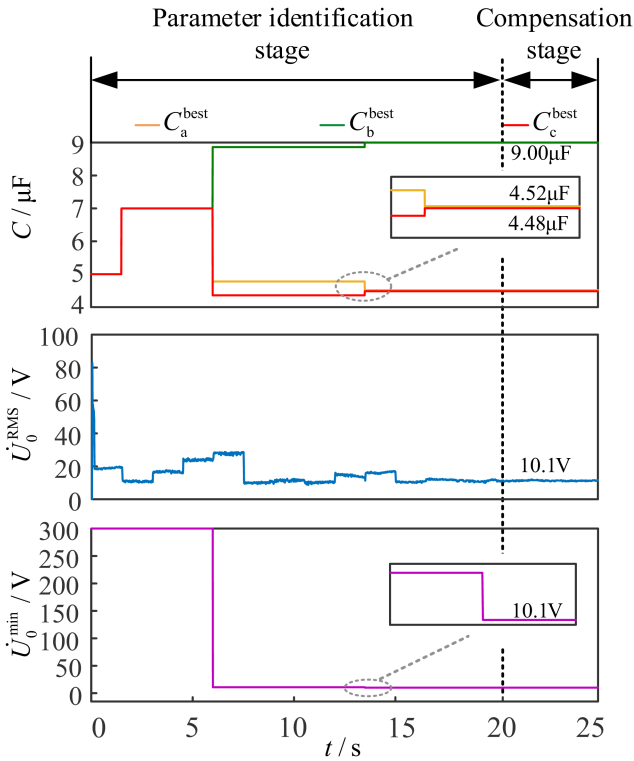
 Fig. 12. Iteration process of algorithm parameters ( $C_{0a} = 4.54 \mu\text{F}$ ,  $C_{0b} = 8.86 \mu\text{F}$ , and  $C_{0c} = 4.56 \mu\text{F}$ ).

affects the change of the CHB branch output current. Ultimately, it leads to changes in the neutral point voltage of the distribution network. During the compensation stage, the CHB branch output current is stabilized and the neutral point voltage is suppressed to a minimum value. The neutral point voltage and reference current values are zoomed in Figs. 13 and 16. Experimental waveforms verified the validity of the proposed method.

A comprehensive comparison of different measurement methods is shown in Table V. From the table, the proposed method has high accuracy. It can identify each phase-to-ground parameter online without any other parameters. Although the comprehensive cost is high, it has multifunctionality. When the distribution network is operating normally, the ACD is used for online identification of each phase-to-ground parameter in distribution networks. The obtained parameters are used to calculate the

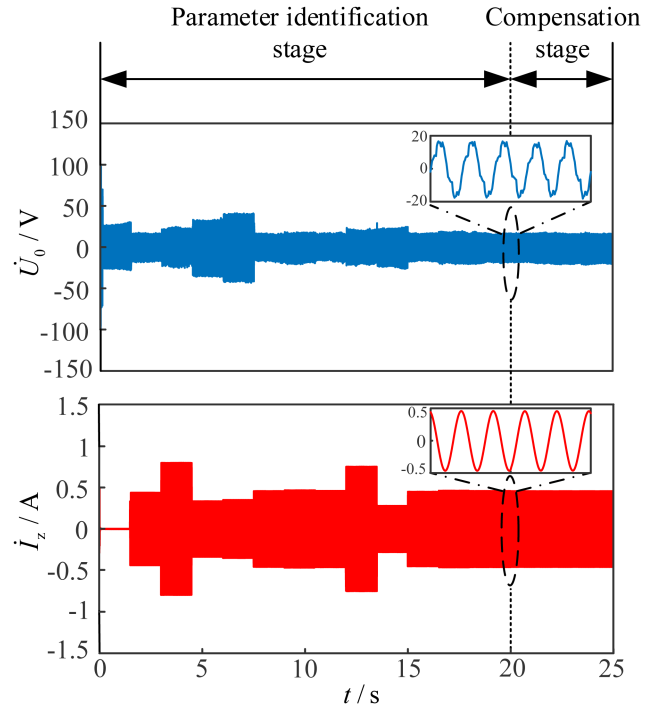

Fig. 13. Experimental waveforms of neutral point voltage and reference current values under neutral point grounded through arc suppression coil.

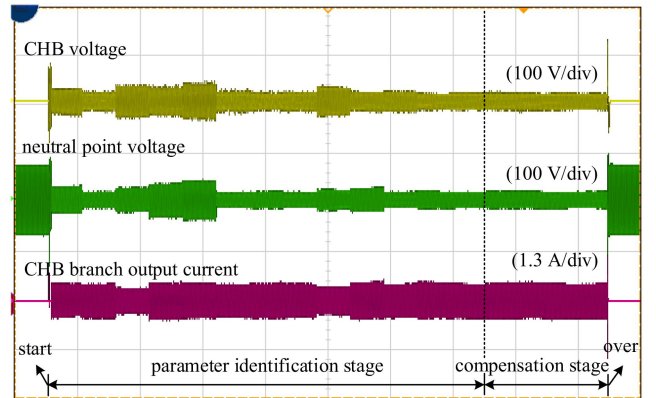

Fig. 14. Waveforms of experimental under neutral point grounded through arc suppression coil.

 TABLE V  
 COMPARISON OF DIFFERENT MEASUREMENT METHODS

Method	Method 1	Method 2	Method 3	Proposed method
Measurement accuracy of $C_0$ (%)	98.6	97.6	98.8	99.1
Identification ( $C_{0a}$ , $C_{0b}$ , $C_{0c}$ )	N	N	N	Y
Additional parameters required	Y	N	Y	N
Online measurement	N	N	N	Y
Comprehensive cost	Low	High	Low	High

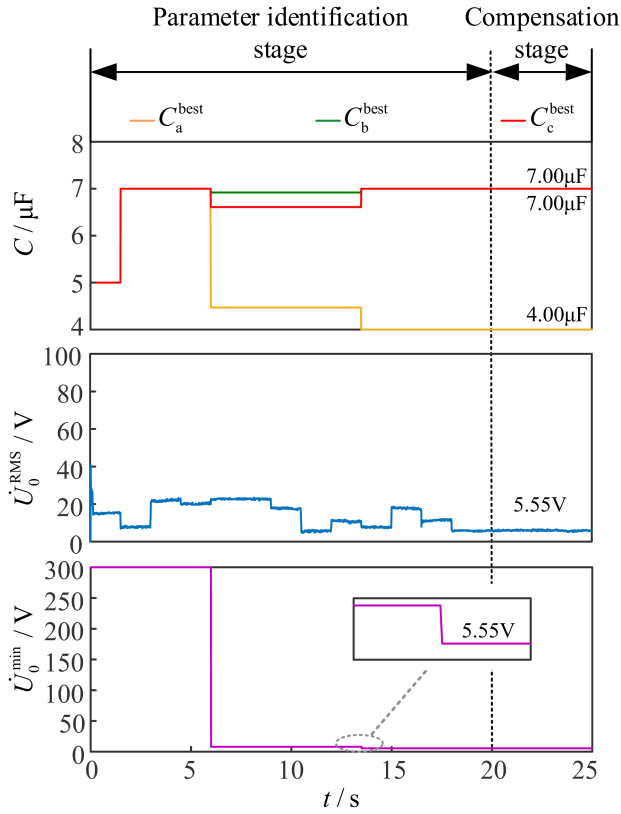

Fig. 15. Iteration process of algorithm parameters ( $C_{0a} = 4.32 \mu\text{F}$ ,  $C_{0b} = 6.89 \mu\text{F}$ , and  $C_{0c} = 6.94 \mu\text{F}$ ).

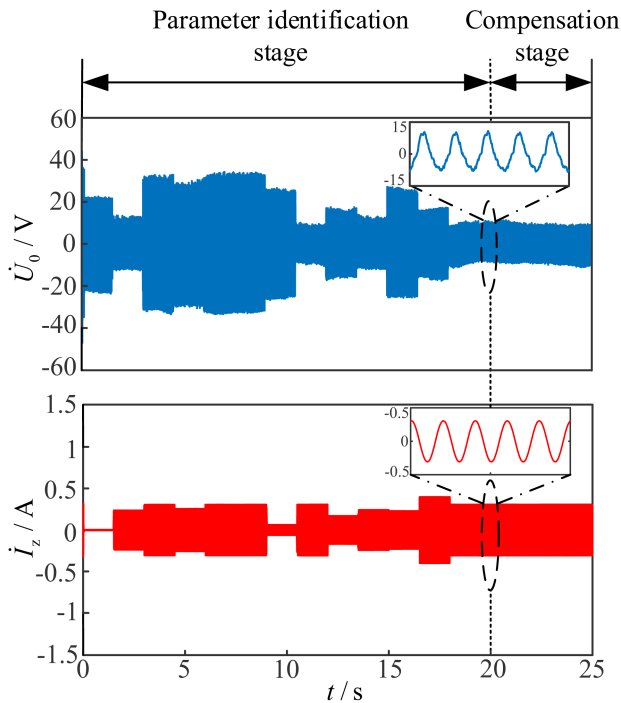

Fig. 16. Experimental waveforms of neutral point voltage and reference current values under neutral point ungrounded.

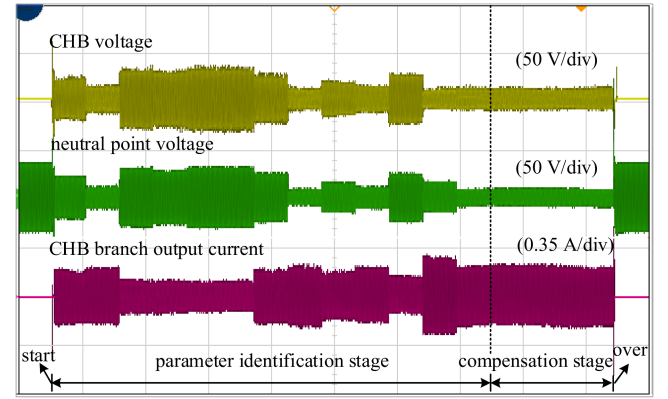

Fig. 17. Waveforms of experimental under neutral point ungrounded.

reference current value, which is injected into the distribution network by ACD to compensate for the three-phase unbalanced voltage caused by the asymmetry of three-phase-to-ground parameters. When an SPG fault occurs, the obtained parameters are used to calculate the reference value for compensating fault current, the ACD is used to limit the current at the fault point.

## VI. CONCLUSION

Most of the phase-to-ground parameters induced between distribution lines and ground are asymmetric, which can result in the generation of unbalanced voltage, shifting the neutral point voltage. To avoid the potential negative impact of asymmetric three-phase-to-ground parameters, this article has analyzed the generation mechanism of three-phase unbalanced voltage and summarized the differences in three-phase unbalanced voltage caused by the asymmetry of three-phase-to-ground parameters under different grounding systems. Therefore, an adaptive active current-type compensation method based on power electronics is proposed. It can adapt to compensate for three-phase unbalanced voltage with different neutral point grounding styles.

In addition, an online split-phase identification parameters strategy based on PSO is proposed in this article, which can accurately identify the individual phase-to-ground parameters of the distribution lines in real time. More importantly, this method can adapt to dynamics in power lines. These parameters can not only be used to calculate the compensation current for three-phase unbalanced voltage and SPG faults but also provide data support for the tuning of ASC and some protective devices. Finally, the feasibility and effectiveness of the proposed method were verified through experiments and simulations, achieving online parameter split-phase identification and three-phase unbalanced voltage compensation.

## REFERENCES

- [1] B. Zhang, M. Guo, Z. Zheng, and Q. Hong, "Fault current limitation with energy recovery based on power electronics in hybrid ac-dc active distribution networks," *IEEE Trans. Power Electron.*, vol. 38, no. 10, pp. 12593–12606, Oct. 2023.

- [2] J. Gao, M. Guo, S. Lin, and D. Chen, "Application of semantic segmentation in high-impedance fault diagnosis combined signal envelope and hilbert marginal spectrum for resonant distribution networks," *Expert Syst. Appl.*, vol. 231, Nov. 2023, Art. no. 120631.
- [3] D. Paul, "Phase-ground fault current analysis and protection of a high-resistance grounded power system," *IEEE Trans. Ind. Appl.*, vol. 56, no. 4, pp. 3306–3314, Jul./Aug. 2020.
- [4] M. Guo, X. Zheng, D. Chen, and N. Yang, "Deep-learning-based earth fault detection using continuous wavelet transform and convolutional neural network in resonant grounding distribution systems," *IEEE Sensors J.*, vol. 18, no. 3, pp. 1291–1300, Feb. 2018.
- [5] X. Wang, H. Zhang, F. Shi, and Q. Wu, "Location of single phase to ground faults in distribution networks based on synchronous transients energy analysis," *IEEE Trans. Smart Grid*, vol. 11, no. 1, pp. 774–785, Jan. 2020.
- [6] K. Liu et al., "Flexible grounding system for single-phase to ground faults in distribution networks: A systematic review of developments," *IEEE Trans. Power Del.*, vol. 37, no. 3, pp. 1640–1649, Jun. 2022.
- [7] Y. Hou et al., "Adaptive active voltage-type arc suppression strategy considering the influence of line parameters in active distribution network," *IEEE Trans. Ind. Electron.*, vol. 70, no. 5, pp. 4799–4808, May 2023.
- [8] R. You and X. Lu, "Voltage unbalance compensation in distribution feeders using soft open points," *J. Mod. Power Syst. Clean Energy*, vol. 10, pp. 1000–1008, May 2022.
- [9] Y. Xue, J. Xie, and B. Xu, "Methods of unbalanced voltage control in non-solidly grounded systems based on current injection," *Int. Trans. Elect. Energy Syst.*, vol. 27, no. 5, 2017, Art. no. e2301.
- [10] R. Zivanovic, P. Schegner, O. Seifert, and G. Pilz, "Identification of the resonant-grounded system parameters by evaluating fault measurement records," *IEEE Trans. Power Del.*, vol. 19, no. 3, pp. 1085–1090, Jul. 2004.
- [11] B. Gustavsen and J. A. Walseth, "A case of abnormal overvoltages in a Petersen grounded 132 kV system caused by broken conductor," *IEEE Trans. Power Del.*, vol. 18, no. 1, pp. 195–200, Jan. 2003.
- [12] P. Toman, J. Drapela, and J. Orsagova, "Solution of voltage asymmetry and reduction of outage time in MV compensated networks," in *Proc. 13th Int. Conf. Harmon. Qual. Power*, 2008, pp. 1–7.
- [13] A. Askarzadeh, "Capacitor placement in distribution systems for power loss reduction and voltage improvement: A new methodology," *IET Gener. Transmiss. Distrib.*, vol. 10, no. 14, pp. 3631–3638, Nov. 2016.
- [14] A. Goharizi, S. Hosseini, M. Sabahi, and G. Gharehpetian, "Three-phase HFL-DVR with independently controlled phases," *IEEE Trans. Power Electron.*, vol. 27, no. 4, pp. 1706–1718, Apr. 2012.
- [15] H. Wang, M. Guo, and W. Cai, "Suppression strategy on neutral point over-voltage in resonant grounding system considering single line-to-ground fault," *Electric Power Syst. Res.*, vol. 206, May 2022, Art. no. 107782.
- [16] W. Wang, L. Yan, X. Zeng, B. Fan, and J. Guerrero, "Principle and design of a single-phase inverter-based grounding system for neutral-to-ground voltage compensation in distribution networks," *IEEE Trans. Ind. Electron.*, vol. 64, no. 2, pp. 1204–1213, Feb. 2017.
- [17] V. Leitloff, L. Pierrat, and R. Feuillet, "Study of the neutral-to-ground voltage in a compensated power system," *Eur. Trans. Elect. Power*, vol. 4, no. 2, pp. 145–153, 1994.
- [18] P. Wang, B. Chen, C. Tian, B. Sun, M. Zhou, and J. Yuan, "A novel neutral electromagnetic hybrid flexible grounding method in distribution networks," *IEEE Trans. Power Del.*, vol. 32, no. 3, pp. 1350–1358, Jun. 2017.
- [19] A. Gargoom, A. Oo, and M. Cavanagh, "A method for calculating the asymmetry in the shunt parameters of power lines in compensated distribution networks," *IEEE Trans. Power Del.*, vol. 35, no. 5, pp. 2168–2176, Oct. 2020.
- [20] K. Ishaque, Z. Salam, M. Amjad, and S. Mekhilef, "An improved particle swarm optimization (PSO)-based MPPT for PV with reduced steady-state oscillation," *IEEE Trans. Power Electron.*, vol. 27, no. 8, pp. 3627–3638, Aug. 2012.
- [21] Z. Liu, H. Wei, Q. Zhong, K. Liu, X. Xiao, and L. Wu, "Parameter estimation for VSI-fed PMSM based on a dynamic PSO with learning strategies," *IEEE Trans. Power Electron.*, vol. 32, no. 4, pp. 3154–3165, Apr. 2017.
- [22] X. Song, J. Zhao, J. Song, and F. Dong, "Local demagnetization fault recognition of permanent magnet synchronous linear motor based on S-transform and PSO-LSSVM," *IEEE Trans. Power Electron.*, vol. 35, no. 8, pp. 7816–7825, Aug. 2020.
- [23] Q. Li, W. Chen, and Y. Wang, "Parameter identification for PEM fuel-cell mechanism model based on effective informed adaptive particle swarm optimization," *IEEE Trans. Ind. Electron.*, vol. 58, no. 6, pp. 10858–10871, Jun. 2011.
- [24] Z. Liu, H. Wei, X. Li, K. Liu, and Q. Zhong, "Global identification of electrical and mechanical parameters in PMSM drive based on dynamic self-learning PSO," *IEEE Trans. Power Electron.*, vol. 33, no. 12, pp. 10858–10871, Dec. 2018.
- [25] Z. Zheng, M. Guo, N. Yang, and T. Jin, "Single-phase flexible arc suppression device based on BSC-SOGI-PLL method for distribution networks," *Int. J. Elect. Power Energy Syst.*, vol. 121, Oct. 2020, Art. no. 106100.
- [26] Z. Wang and X. Meng, "Design of new measurement system for capacitance current in distribution network," *J. Elect. Meas. Instrum.*, vol. 26, no. 1, pp. 78–83, 2012.
- [27] Z. Zheng, M. Guo, T. Jin, and J. Liu, "A novel method of insulation parameters measurement based on hybrid flexible arc suppression device in distribution networks," *Int. J. Elect. Power Energy Syst.*, vol. 130, Sep. 2021, Art. no. 106982.
- [28] K. Yu et al., "Insulation parameter online measurement technology based on extended zero-sequence circuits for resonant grounding distribution networks," *IEEE Trans. Power Del.*, vol. 37, no. 6, pp. 4679–4689, Dec. 2022.



**Moufa Guo** (Member, IEEE) was born in Fujian province, China, in 1973. He received the B.S. and M.S. degrees in electrical engineering from Fuzhou University, Fuzhou, China, in 1996 and 1999, respectively, and the Ph.D. degree in electrical engineering from Yuan Ze University, Taoyuan, Taiwan, in 2018.

Since 2000, he has been with Fuzhou University, where he is currently a Professor with the College of Electrical Engineering and Automation. His research interests include information processing, protection control, and flexible arc suppression of single-line-to-ground fault in distribution networks.



**Yaohui Jiao** was born in Henan province, China, in 1999. He received the B.S. degree in electric engineering from Hebei Agricultural University, Hebei, China, in 2021. He is currently working toward the M.S. degree in electric machines and electric apparatus from Fuzhou University.

His current research focuses on the protection control and flexible arc suppression of single-line-to-ground fault in distribution networks.



**Zeyin Zheng** (Member, IEEE) received the B.S. degree in electrical engineering from Fuzhou University, Fuzhou, China, in 2014, and the Ph.D. degree in electrical engineering from Fuzhou University and Yuan Ze University, Taoyuan, Taiwan, in 2021.

He is currently an Associate Professor with Fuzhou University. His research interests include power distribution system automation, flexible active arc suppression of single-phase ground faults, and protection and control of distribution systems.



**Binlong Zhang** (Student Member, IEEE) received the B.S. degree in electrical engineering in 2020 from Fuzhou University, Fujian, China, where he is currently working toward the Ph.D. degree in electrical engineering.

His current research focuses on the protection and control of power systems with a high penetration of renewable energy resources with power electronics.



**Qiteng Hong** (Senior Member, IEEE) received the B.Eng. (Hons.) and Ph.D. degrees in electronic and electrical engineering from the University of Strathclyde, Glasgow, U.K., in 2011 and 2015, respectively.

He is currently a Senior Lecturer (Associate Professor) with the University of Strathclyde. His current research focuses on power system protection and control in future networks with high penetration of renewables.

Dr. Hong is a member of IEEE Working Group P2004 and IEEE Task Force on Cloud-Based Control and Co-Simulation of Multi-Party Resources in Energy Internet. He was a Regular Member of the completed CIGRE WG B5.50.



**Jiahao Lin** (Student Member, IEEE) was born in Fujian province, China, in 1997. He received the B.S. degree in electric machines and electric apparatus in 2019 from Fuzhou University, Fujian, China, where he is currently working toward the Ph.D. degree in electric machines and electric apparatus.

His current research focuses on the detection and location of single-line-to-ground faults in distribution networks.