

# Accurate Analysis and Design of the Circuit Parameters of *LLC* DC–DC Converter With Synchronous Rectification

Xiang Zhou , Member, IEEE, Laili Wang , Senior Member, IEEE, Yongmei Gan , Member, IEEE, Huan Luo , Member, IEEE, Yan-Fei Liu , Fellow, IEEE, and Paresh C. Sen, Life Fellow, IEEE

**Abstract**—In high-load-current *LLC* dc–dc converter, synchronous rectification (SR) is usually used to reduce the secondary loss. As a lossless, low-cost, and small-volume SR control strategy, the drain–source voltage of SR switches sensing method is used widely in industrial applications. However, when the load current increases, the voltage ringing across SR switches during O stage is more and more severe and reaches zero eventually. When the voltage ringing reaches around zero in *LLC* converter, the voltage-sensing-method SR controller will generate the false driving signal, which makes SR switches turn ON early and causes the converter works abnormally. This article presents the accurate analysis and design of the circuit parameters of *LLC* dc–dc converter to prevent the voltage ringing across the SR switches reaches around zero. The voltage ringing model is established, and the parameters design principle is given. By using the proposed design guideline, the voltage ringing across SR switches will always be higher than zero over the full load range, which eliminates the turn-ON early issue or turn-ON several times in one cycle issue. Therefore, this article can provide a design reference and guideline for the high-load-current and high-output-power *LLC* converter with voltage sensing SR control strategy. A 2.16 kW SR *LLC* dc–dc converter prototype is built according to the proposed design guideline, and the experimental results verify the correctness and effectiveness of the analysis.

**Index Terms**—*LLC* dc–dc converter, parameters design, synchronous rectifier, turn-ON early.

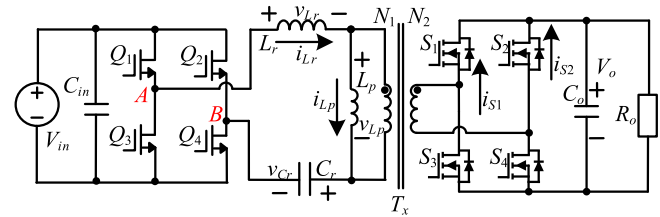

Fig. 1. Full-bridge *LLC* converter with SR.

## I. INTRODUCTION

**L**LC resonant converter is becoming more and more popular as both zero-voltage switching (ZVS) of the primary-side switches and zero-current switching of the secondary-side rectifiers can be achieved [1]. Along with the maturity and widespread application of the wide bandgap devices, the higher switching frequency, power density, and efficiency become the developing trend of the *LLC* converters. As the switching frequency is high, the parasitic parameters have an increasing effect on the performance of the *LLC* converter. The voltage oscillation of the *LLC* resonant converter caused by the parasitic parameters under light load is studied in [2]–[4]. Wu and Shi [5] reveal that the parasitic parameters of the switches in the *LLC* converter are the key parameter for determining the primary conduction losses. In [6]–[10], the various optimal parameters' designs of *LLC* converter are presented to improve the performance of the efficiency, switching frequency range, and voltage gain.

In decades, *LLC* resonant converters are used widely in many different applications. The typical applications for *LLC* converters are electric vehicles' applications, renewable generation systems, data center applications, etc. In these applications, the converters usually operate with a low output voltage and a high load current [11], [12]. As the conduction loss is related to the square of rms current, the transformer secondary conduction loss is dominant as the secondary current stress is high. Because the ON-state resistance of the switch ( $R_{ds,on}$ ) is very small, and the product of the  $R_{ds,on}$  and the current flowing through the switch is much smaller than the forward voltage  $V_F$  of the diode. Therefore, synchronous rectification (SR) can reduce the conduction loss significantly [12], [13].

The full-bridge *LLC* converter with SR is shown in Fig. 1. To improve further efficiency of the *LLC* converter, an optimal SR

Manuscript received 16 March 2022; revised 2 June 2022; accepted 24 July 2022. Date of publication 28 July 2022; date of current version 6 September 2022. This work was supported in part by the State Key Laboratory of Electrical Insulation and Power Equipment under Grant EIPE22319, in part by the Fundamental Research Funds for the Central Universities under Grant xzy012022050, in part by China Postdoctoral Science Foundation under Grant 2020M673397, and in part by grants from the Power Electronics Science and Education Development Program of Delta Group. Recommended for publication by Associate Editor D. Qiu. (Corresponding author: Laili Wang.)

Xiang Zhou, Laili Wang, and Yongmei Gan are with the State Key Laboratory of Electrical Insulation and Power Equipment, Xi'an Jiaotong University, Xi'an 710049, China (e-mail: pecel\_zhouxiang@163.com; llwang@mail.xjtu.edu.cn; ymgan@mail.xjtu.edu.cn).

Huan Luo is with the College of Electrical Engineering, Sichuan University, Chengdu 610064, China (e-mail: luohuan\_swjtu@163.com).

Yan-Fei Liu and Paresh C. Sen are with the Department of Electrical and Computer Engineering, Queen's University, Kingston, ON K7L 3N6, Canada (e-mail: yanfei.liu@queensu.ca; senp@queensu.ca).

Color versions of one or more figures in this article are available at <https://doi.org/10.1109/TPEL.2022.3194588>.

Digital Object Identifier 10.1109/TPEL.2022.3194588

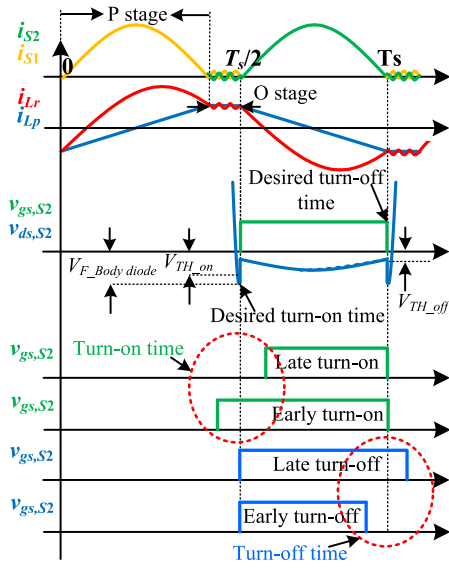

Fig. 2. Issues when the SR switches are turned ON and turned OFF.

control is required to keep the SR switches always conducting when the secondary current flows to load and avoid a long conduction time of the body diode [13]. However, there are some issues when the SR switches are turned ON and turned OFF.

From Figs. 1 and 2, during the time 0 to  $T_s/2$ , when the voltage across inductor  $L_p$  is positive clamped and the voltage  $v_{Lp} = nV_O$ , this operation stage is denoted as P stage. When the voltage across inductor  $L_p$  is negative clamped and the voltage  $v_{Lp} = -nV_O$ , this operation stage is denoted as N stage. When the voltage across inductor  $L_p$  is not clamped and the secondary switches are turned OFF, this operation stage is denoted as O stage. Generally, the LLC converter could operate in six major modes, which are PO, PON, PN, NP, NOP, and OPO [6], and PO mode is shown in Fig. 2. As the voltage ringing generally occurred during O stage, only the operation mode including O stage is analyzed in this article. NOP mode suffers the reverse recovery current problem; thus, this stage is not designed in the proposed prototype to optimize the efficiency. In PON mode, the O stage is short; thus, the voltage ringing has a limit effect on the converter even if the SR switches are turned ON early. OPO mode exits in light-load condition, and the voltage ringing is not severe according to the theoretical analysis in this article. Therefore, the PO mode is selected as an example to analyze in this article.

Fig. 2 shows the late turn-ON, early turn-ON, late turn-ON, and early turn-OFF four issues in the LLC converter with SR. For these issues, current sensing, voltage sensing, and theoretical calculation are the three main methods that are proposed to make the SR switches conduct properly and achieve optimal efficiency.

#### A. Late Turn-ON Issue

In LLC converter, the transformer secondary current flows through the rectifier to the load during P stage, and there is no current flowing through the rectifier during O stage [14]. At the beginning of the P stage, the parasitic output capacitance of the

SR switches needs to be discharged to achieve ZVS turn-ON. As the transformer secondary current is small at the beginning of the P stage under light load, a long time is required to discharge the output capacitance of the SR switches fully. In [15], the SR switches turn-ON signal is synchronized with the primary-side gate signal with a small delay by considering the microchip delay. If the delay time is too short, ZVS turn-ON of the SR switches cannot be achieved. If the delay time is too long, the SR switches will be turned ON late and cause a large loss due to the long conduction time of the body diodes of the switches.

In [16], the secondary current is sensed to generate a proper driving signal of the SR switches by the current transformers (CTs). However, the transformer secondary current stress is high. Thus, the CTs will cause extra loss and cost, which is unsuitable for secondary current sensing. The low-current-stress primary current is detected in [17] and [18] to reduce the conduction loss of CTs. As the primary resonant current cannot reflect the rectifier current due to the magnetizing current, an extra compensating winding is required to cancel out the magnetizing current [17], [18]. The auxiliary winding and the detecting circuits are proposed in [19] and [20] to emulate the secondary rectification current by using the lossless and impassive components. But it still increases the complexity and cost of the converter.

Although the current sensing can make SR switches conduct well, it is not a popular method due to extra loss, cost, and bulky. The voltage sensing is used in many industrial applications as only the voltage across the drain to the source of the SR switches is required to detect, which benefits from no extra loss, small volume, and cheap. As shown in Fig. 2, at the end of the O stage, the voltage  $v_{ds,S2}$  decreases. When the voltage  $v_{ds,S2}$  decreases to the voltage of body diodes  $-V_F$  at the beginning of the P stage, the voltage  $v_{ds,S2}$  is lower than the threshold voltage  $V_{TH,on}$ , then the SR switches are turned ON. Along with the transformer secondary current decreasing to zero, the voltages across SR switches are higher than the threshold voltage  $V_{TH,off}$ , then the SR switches are turned OFF.

In industrial applications, many manufacturers propose the voltage sensing chips for the SR due to high efficiency, low cost, and stable performance, for example, SRK2000A of the ST, NCP4305 of the Onsemi, UCC24624 of the TI, TEA1795T of the NXP, and MP6924 of the MPS.

#### B. Early Turn-OFF Issue

For the LLC converter with a short fixed conduction time of SR switches over full load range and input voltage conditions, the early turn-OFF issue is occurring as the P stage time changes along with load and input voltage changes [21].

As mentioned above, voltage sensing is an economical and reliable method to solve abnormal turn ON or OFF. However, due to the stray inductance in both the PCB traces and the SR switches package, the voltage across the stray inductance is also detected, which causes the SR switches turn-OFF early and increases the loss of body diodes of SR switches [13]. To solve this problem and improve the efficiency of the converter, Wang et al. [22]–[24] proposed the auxiliary circuit to compensate

for the stray inductance, and SRs can be turned OFF properly with almost no body diode conduction. However,  $R_{ds,on}$  is not constant at different current stresses, temperatures, driving voltages, etc. Thus, the compensation circuits are not precise at all the operating conditions.

In [25] and [26], the digital detecting methods for the SR switches are proposed based on the voltage sensing method. When the voltage of body diodes  $-V_F$  is detected after the SR switches are turned OFF, it means that the SR switches are turned OFF early and the body diodes are turned ON. In the next cycle, the digital controller generates a longer conduction time for SR switches. When the voltage of body diodes  $-V_F$  is not detected after the SR switches are turned OFF, it means that the SR switches are turned OFF properly. In the next cycle, the digital controller generates a shorter conduction time for SR switches. By using this control strategy, the conventional turn-OFF threshold voltage  $V_{TH,off}$  is not required to be detected. Thus, the early turn-OFF issues are solved in the conventional voltage sensing method, and the SR switches can be turned ON with almost no body diode conduction. To improve the steady-state performance and reliability during transients, the primary current is also sensed in [27] to generate an analytic–adaptive method based on the digital detecting of SR switches voltage.

A high-voltage sensing method is proposed in [28]. The resonant capacitor voltage is detected to control the SR switches. As the resonant capacitor voltage is high, the sensing circuit is complex and limited to the high voltage stress.

To remove the current or voltage sensing circuits and reduce the cost, Zhu et al. [15] and Ren et al. [29]–[33] build some accurate mathematical modes to calculate the turn-ON time, the turn-OFF time, and the conduction time related to the switching frequency and load condition, which makes the driving signals of SR switches adjusted adaptively. However, the precise information of the output voltage, the load current, and the input voltage is required to judge which operation stage of the *LLC* converter is. Thus, these methods are not suitable in the high-load-current applications as the precise load-current sensing still requires a lossy resistor sensor, complex detecting circuits, or bulky CTs.

### C. Late Turn-OFF Issue

As shown in Fig. 2, if the SR switches still conduct after the end of P stage, the load current would flow from the drain to the source of the SR switches; thus, the output energy would be transferred back to the primary side. In [34] and [35], when the secondary switches are turned OFF late than the primary switches, the circulating energy caused by a reverse current increases rms currents, which deteriorate the efficiency of the converter. In addition, a large reverse current increases the turn-OFF current and induce a huge drain spike, which increases the switching loss and voltage stress of the secondary switches [36].

For *LLC* converter, under the very light-load condition, there is an unintended increase of output voltage beyond the regulation limit, and the output voltage is difficult to regulate even if the converter operates at a very high switching frequency [37]. In

[38], the regulation capability can be improved and the output voltage is stable under a very light load by using the reverse current. By adjusting the turn-OFF delay time to control the reverse current, the output energy can be transferred to the primary side; thus, the voltage gain can be reduced. Therefore, a lower switching frequency can regulate the output voltage under the light load, which reduces the switching loss and driver loss significantly.

### D. Early Turn-ON Issue

Similar to the late turn-OFF issue, the early turn-ON issue also causes the reverse current and increases rms currents and conduction loss. However, the relevant past works of early turn-ON issues are scarce.

As mentioned above, lots of voltage sensing Integrate Circuit (ICs) are proposed by the main power management companies due to lossless, low cost, and stable performance. Thus, voltage sensing ICs are very popular for SR switches in industrial applications. However, a severe voltage ringing occurs during O stage due to the resonant components and the parasitic parameters. If the voltage sensing ICs are used to generate the driving signal for SR switches, a voltage ringing will lead to the early turn-ON issue [39].

As a severe voltage ringing causes the voltage across the SR switches reaches to zero several times during O stage, in [10] and [34], the calculated control strategy is used for the primary and secondary switches by the digital controller; thus, the SR switches can be turned ON correctly. A turn-ON delay time longer than the O stage time is designed in [36] to prevent the permuted turn-ON of SR switches and the leading edge inversion current. However, when there is no voltage ringing across SR switches, a long turn-ON delay time will make the body diodes of SR switches conduct and increase the conduction loss. The control of a variable turn-ON delay time is proposed in [36], but it still increases the cost and complexity of the controller as the leading edge inversion current is required to be detected. In [40], the polarity of the voltage across the transformer is detected to judge that SR switches should be conducted in P stage instead of O stage, which eliminates the misconducting of the SR switches caused by the voltage sensing ICs detecting voltage ringing. Similarly, the polarity of the resonant current is obtained by detecting the inductor voltage to avoid the false driving pulses problem caused by the oscillation in O stage [41]. However, in these methods, the polarity is hard to determine due to the oscillation of the rectifier voltage. In addition, extra sensing circuits are required, which increases the cost and the complexity compared to only using the voltage sensing ICs.

In some voltage sensing ICs, the minimum turn-ON and turn-OFF time can be set to avoid the oscillation closed to the threshold turn-ON or turn-OFF voltage [42]. However, it is still difficult to design a proper fixed minimum turn-ON and turn-OFF time that can be used over the full load and input voltage ranges.

Fig. 3(a) shows that the voltage sensing method IC is used in the SR *LLC* converter in Fig. 1. In Fig. 3(b), if the minimum turn-ON time is longer than the O stage time, the switches  $S_1$  and

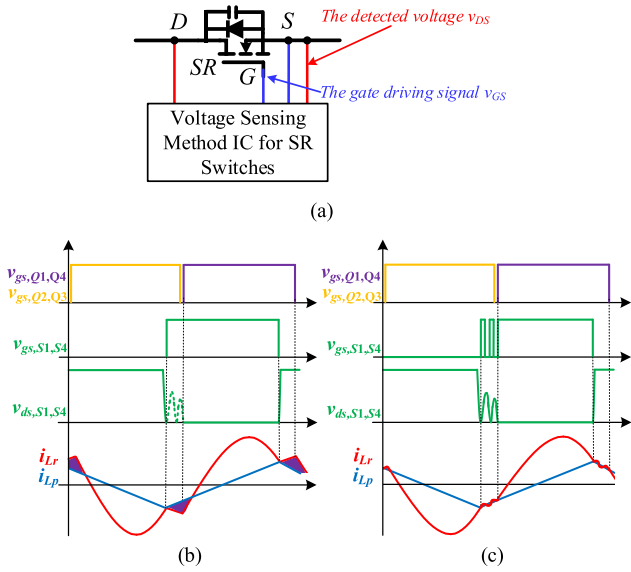

Fig. 3. Waveforms of the SR *LLC* converter when (a) voltage sensing method IC is used, (b) minimum turn-ON time is too long, and (c) minimum turn-ON time is too short.

$S_4$  are turned ON when  $v_{ds,S1}$  and  $v_{ds,S4}$  decreases to  $-V_F$  for the first time at O stage, which causes the early turn-ON issue and reverse current shown with purple block. As shown in Fig. 3(c), if the minimum turn-ON time is shorter than the oscillation time, the switches  $S_1$  and  $S_4$  are turned ON when  $v_{ds,S1}$  and  $v_{ds,S4}$  decrease to  $-V_F$  every time at O stage, which causes the SR switches to switch several times during one cycle and increases the switching loss significantly. As the switching frequency range of the *LLC* converter is wide, the O stage time range is very wide. Thus, a proper minimum turn-ON time is difficult to design. Corresponding to the theoretical waveforms in Fig. 3, the SIMPLIS simulated waveforms of the *LLC* converter with the voltage sensing method IC NCP4305 are shown in Fig. 4. The waveforms in Fig. 4 are consistent with that in Fig. 3, which verifies the early turn-ON issue by using the voltage sensing ICs in the *LLC* converter.

In summary, if we want to use only the voltage sensing ICs and eliminate the issues, as shown in Figs. 3 and 4, an effective and useful method is the voltage ringing during O stage that should be studied and a severe voltage ringing is eliminated by an optimal design of the circuit parameters.

In this article, the accurate analysis and design of the circuit parameters of *LLC* dc-dc converter with SR is proposed to avoid the voltage ringing reaching zero during O stage. Thus, the early turn-ON issue can be solved, and the voltage sensing ICs can be used directly to drive the SR switches well, which simplifies the driving circuit and control strategy of the SR switches. The rest of this article is organized as follows. The analysis of the voltage across SRs is presented in Section II. Section III proposes the optimal design of the circuit parameters to avoid the turn-ON early issue of the SR switches. The simulated and experimental verification is shown in Sections IV and V. Finally, Section VI concludes this article.

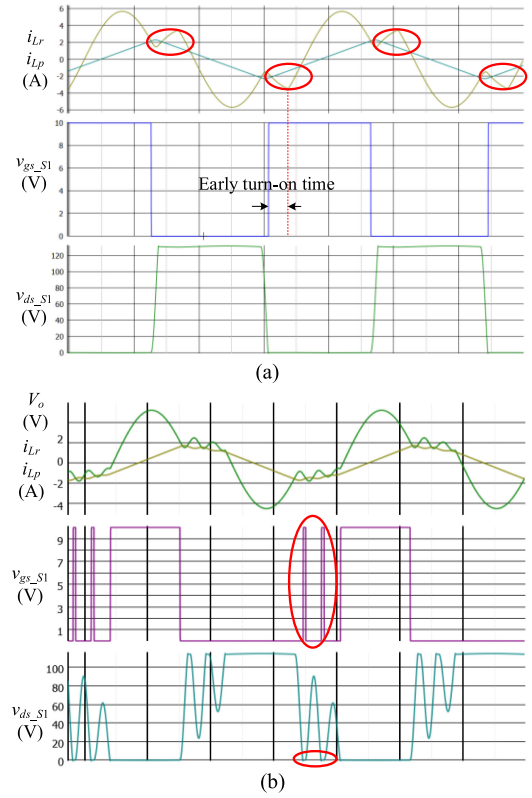

Fig. 4. SIMPLIS simulated waveforms of the *LLC* converter with the voltage sensing ICs NCP4305. (a) Minimum turn-ON time is too long. (b) Minimum turn-ON time is too short.

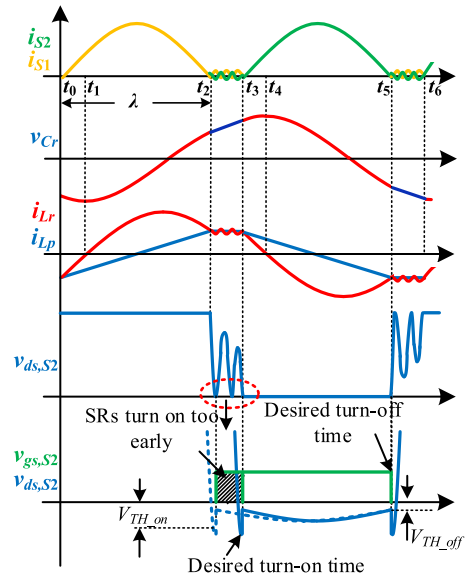

Fig. 5. Key waveforms of the *LLC* converter with SR.

## II. ANALYSIS OF THE VOLTAGE ACROSS SR SWITCHES

Fig. 5 shows the key waveforms of the *LLC* converter with SR by using the voltages sensing ICs.

As shown in Fig. 5, during O stage ( $t_2-t_3$ ), there is voltage ringing across the SR switches, such as  $v_{ds,S2}$ . In *LLC* converter,

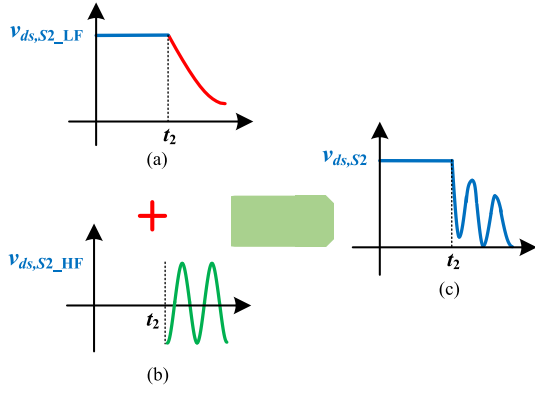

Fig. 6. Synthesis of the voltage ringing across the SR switches. (a) Low-frequency component. (b) High-frequency component. (c) Synthesized voltage ringing across the SRs.

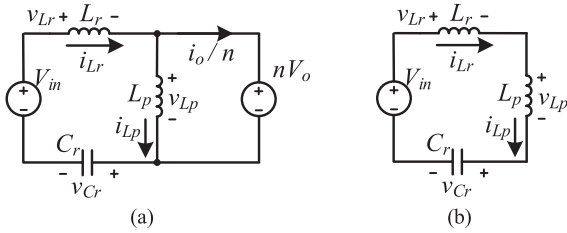

Fig. 7. Equivalent circuit of the LLC dc-dc converter at (a) P stage and (b) O stage.

the SR switches are always turned-OFF during O stage, and there is no energy that is transferred from the transformer primary to the secondary. However, for the LLC converter with voltage sensing SR controller, if the voltage ringing across the SR switches reaches threshold voltage  $-V_{th,on}$  for several ten nanoseconds continuously, the gate driving signals of the SR switches are generated by the SR controller. Then, the SR switches are turned ON early, and the energy is transferred back to the transformer primary from the transformer secondary, which makes the circuit work abnormally. In Fig. 5, the  $v_{ds,S2}$  shown with dashed line presents the real waveforms caused by the voltage ringing, and the  $v_{ds,S2}$  shown with solid line presents the desired turn-ON gate driving signal, and the shaded area presents the turn-ON early time.

To solve the turn-ON early issue of the SR switches, the voltage ringing across SR switches is analyzed first. As shown in Fig. 6, since  $t_2$ , the voltage ringing across the SR switches is synthesized by the low-frequency component and the high-frequency component. The two components are analyzed in detail below.

#### A. Low-Frequency Component Analysis of the Voltage Ringing Across the SR Switches

During  $t_0-t_2$  in Fig. 5, the equivalent circuit of P stage of the LLC dc-dc converter in Fig. 1 is shown in Fig. 7(a). During  $t_2-t_3$  in Fig. 5, the equivalent circuit of O stage of the LLC dc-dc converter in Fig. 1 is shown in Fig. 7(b).

Defining that the  $K$ , the resonant angle frequency  $\omega_r$  between  $L_r$  and  $C_r$ , and the resonant angle frequency  $\omega_p$  between

$(L_p+L_r)$  and  $C_r$  are

$$\begin{cases} K = \frac{L_p}{L_r} \\ \omega_r = \frac{1}{\sqrt{L_r C_r}} \\ \omega_p = \frac{1}{\sqrt{(L_r+L_p)C_r}} \end{cases} \quad (1)$$

As shown in Fig. 5,  $\lambda = t_2-t_0$  is the duration of P stage. To simplify the analysis, according to [43],  $\lambda$  can be approximated as

$$\lambda \approx \frac{f_s}{f_{r1}} \cdot \frac{T_s}{2} = \frac{\pi}{\omega_r} \quad (2)$$

By using the analysis method in [6], the resonant capacitor voltage  $v_{Cr,LF}(t)$  during  $t_2-t_3$  can be obtained as

$$\begin{aligned} v_{Cr,LF}(t-t_2) = & \left( -2nV_o + V_{in} + \frac{V_o^2}{4C_r R_o V_{in} f_s} \right) \\ & \times \cos \omega_p(t-t_2) + \frac{nV_o \pi \sqrt{K+1}}{2K} \sin \omega_p(t-t_2) + V_{in} \end{aligned} \quad (3)$$

where transformer turns ratio is  $n = N_1:N_2$ .

During  $t_2-t_3$ , the current  $i_{Lr}$  can be regarded as equal to  $i_{Lp}$ . Therefore, the magnetizing inductor voltage  $v_{Lp,LF}$  can be calculated as

$$v_{Lp,LF}(t-t_2) = \frac{L_p}{L_p+L_r} [V_{in} - v_{Cr,LF}(t-t_2)]. \quad (4)$$

According to Kirchhoff voltage laws (KVL), the low-frequency component of the voltage ringing across the SR switch  $S_2$   $v_{ds,S2,LF}(t)$  during  $t_2-t_3$  is

$$v_{ds,S2,LF}(t-t_2) = \left( V_o + \frac{v_{Lp}(t-t_2)}{n} \right) / 2. \quad (5)$$

Substituting (3) and (4) into (5), the low-frequency component of the voltage ringing across the SR switch  $S_2$   $v_{ds,S2,LF}(t)$  can be rewritten as

$$\begin{aligned} v_{ds,S2,LF}(t-t_2) = & \frac{V_o}{2} - \frac{K}{2n(K+1)} \\ & \times \left[ \left( -2nV_o + V_{in} + \frac{V_o^2}{4C_r R_o V_{in} f_s} \right) \cos \omega_p(t-t_2) \right. \\ & \left. + \frac{nV_o \pi \sqrt{K+1}}{2K} \sin \omega_p(t-t_2) \right]. \end{aligned} \quad (6)$$

#### B. High-Frequency Component Analysis of the Voltage Ringing Across the SR Switches

During  $t_2-t_3$  in Fig. 5, the converter circuit is shown in Fig. 8(a) when the parasitic capacitance  $C_p$  of the transformer and the parasitic output capacitance  $C_{oss}$  of the SR switches are considered.

As the capacitance  $C_r$  is much higher than  $(C_{oss}+C_p)/n^2$ , the dc source  $V_{in}$  and  $V_o$ , and the capacitance  $C_r$  can be ignored when the high-frequency component of the voltage ringing across the SR switches is analyzed. Thus, the equivalent circuit of the converter during  $t_2-t_3$  is shown in Fig. 8(b). Defining that the  $C_e$  is

$$C_e = (C_{oss} + C_p). \quad (7)$$

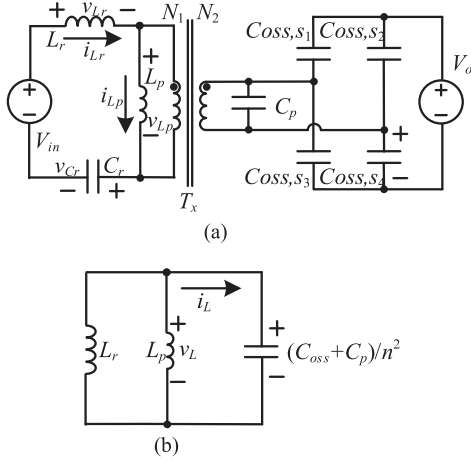

Fig. 8. Equivalent circuit of the LLC dc-dc converter during  $t_2-t_3$ . (a) Converter circuit during  $t_2-t_3$ . (b) Equivalent circuit.

The resonant angle frequency  $\omega_h$  between  $(L_p//L_r)$  and  $C_e/n^2$  is

$$\omega_h = \frac{1}{\sqrt{\frac{L_r L_p}{(L_r + L_p)} \frac{C_e}{n^2}}}. \quad (8)$$

According to KVL, the equation of the equivalent circuit in Fig. 8(b) satisfies

$$\frac{L_r L_p}{(L_r + L_p)} \frac{C_e}{n^2} \frac{d^2 v_L}{dt^2} + v_L = 0. \quad (9)$$

Then, the general solution of  $v_{L,HF}(t-t_2)$  during  $t_2-t_3$  can be obtained as

$$v_{L,HF}(t-t_2) = C_1 \cos \omega_h(t-t_2) + C_2 \sin \omega_h(t-t_2). \quad (10)$$

From (10), the general solution of  $i_{L,HF}(t-t_2)$  is

$$i_{L,HF}(t-t_2) = \frac{C_e}{n^2} \frac{dv_{L,HF}(t-t_2)}{dt} = \frac{\omega_h C_e}{n^2} [-C_1 \sin \omega_h(t-t_2) + C_2 \cos \omega_h(t-t_2)]. \quad (11)$$

As the resonant capacitor voltage  $v_{C_r}(t)$  and the resonant inductor current  $i_{L_r}(t)$  are continued, it has

$$\begin{cases} v_{L,HF}(t_{2+}) = v_{L,HF}(t_{2-}) = nV_o - v_{L_p,LF}(t_2) \\ i_{L,HF}(t_{2+}) = i_{L,HF}(t_{2-}) = 0. \end{cases} \quad (12)$$

As the current flows from the primary side to the secondary side of the transformer is zero during O stage, the current  $i_L(t_2)$  is zero. In addition, substituting (4) into (12), it has

$$\begin{cases} C_1 = nV_o - v_{L_p,O}(t_2) \\ \quad = nV_o + \frac{K}{K+1} \left( -2nV_o + V_{in} + \frac{V_o^2}{4C_r R_o V_{in} f_s} \right) \\ C_2 = 0. \end{cases} \quad (13)$$

Thus, the voltage  $v_{L,HF}$  is

$$v_{L,HF}(t-t_2) = \left[ nV_o + \frac{K}{K+1} \left( -2nV_o + V_{in} + \frac{V_o^2}{4C_r R_o V_{in} f_s} \right) \right]$$

$$\cos \omega_h(t-t_2). \quad (14)$$

As the voltage across switch  $S_2$  and the voltage across switch  $S_3$  are the same, the high-frequency component of the voltage  $v_{ds,S2,HF}$  is

$$\begin{aligned} v_{ds,S2,HF}(t-t_2) &= \frac{v_{L,HF}}{2} n \\ &= \left[ \frac{V_o}{2} + \frac{K}{2n(K+1)} \left( -2nV_o + V_{in} + \frac{V_o^2}{4C_r R_o V_{in} f_s} \right) \right] \\ &\quad \times \cos \omega_h(t-t_2). \end{aligned} \quad (15)$$

Combining the high-frequency component analysis and the low-frequency component analysis, according to (6) and (15), the real voltage  $v_{ds,S2}$  during  $t_2-t_3$  can be obtained as

$$\begin{aligned} v_{ds,S2}(t-t_2) &= v_{ds,S2,LF}(t-t_2) + v_{ds,S2,HF}(t-t_2) \\ &= \frac{V_o}{2} - \frac{K}{2n(K+1)} \left[ \begin{aligned} &\left( -2nV_o + V_{in} + \frac{V_o^2}{4C_r R_o V_{in} f_s} \right) \\ &\times \cos \omega_p(t-t_2) \\ &+ \frac{nV_o \pi \sqrt{K+1}}{2K} \sin \omega_p(t-t_2) \end{aligned} \right] \\ &\quad + \left[ \frac{V_o}{2} + \frac{K}{2n(K+1)} \left( -2nV_o + V_{in} + \frac{V_o^2}{4C_r R_o V_{in} f_s} \right) \right] \\ &\quad \times \cos \omega_h(t-t_2). \end{aligned} \quad (16)$$

### C. Simulated Verification

To verify the calculated results, a PSIM simulation is built. The following assumptions are made: the resonant components are  $L_r = 20 \mu\text{H}$ ,  $L_p = 220 \mu\text{H}$ , and  $C_r = 5 \text{ nF}$ , the switching frequency is 330 kHz, and the parasitic output capacitance of the SR switches  $C_{oss,SR} = 1500 \text{ pF}$ . When the full-bridge LLC converter operates at 400 V input and 54 V output, Fig. 9(a) shows the simulated results and the theoretical results with the 10 A load current, and Fig. 9(b) shows the simulated results and the theoretical results with 20 A load current. The upper parts in Fig. 9(a) and (b) are the simulated results of the voltage  $v_{ds,S2}$ , and the voltages ringing during O stage are zoomed in and shown in the lower parts in Fig. 9(a) and (b), respectively.

From Fig. 9, the simulated results and the theoretical results are highly consistent, which verify the correctness of the theoretical analysis shown in (16). As can be seen from Fig. 9(a) and (b), along with the increasing load current, the voltage across the SR switch reaches zero during  $t_2-t_3$ . If the voltages across the SR switches are always higher than zero during  $t_2-t_3$ , the turn-ON early issue can be solved. Thus, an optimal design of the circuit parameters and the load conditions should be analyzed to solve the turn-ON early issue.

### III. OPTIMAL DESIGN OF THE CIRCUIT PARAMETERS TO AVOID THE TURN-ON EARLY ISSUE OF SR SWITCHES

From (16), we can see that the voltage ringing across the SR switches depends on 12 variables, which are the output voltage  $V_o$ , the input voltage  $V_{in}$ , the magnetizing inductance  $L_p$ , the series resonant frequency  $f_r$ , the series resonant inductance

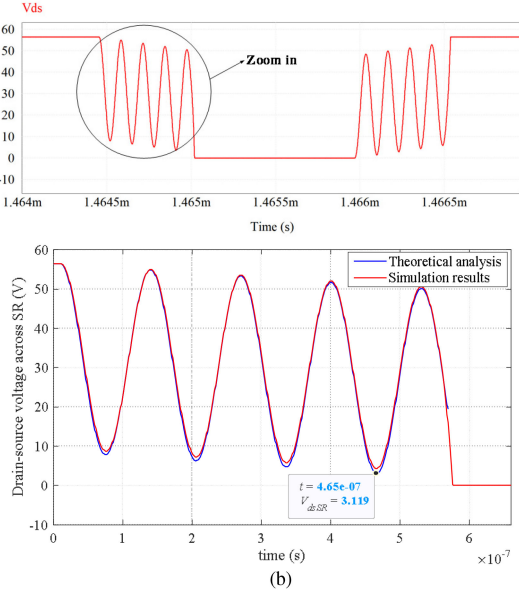
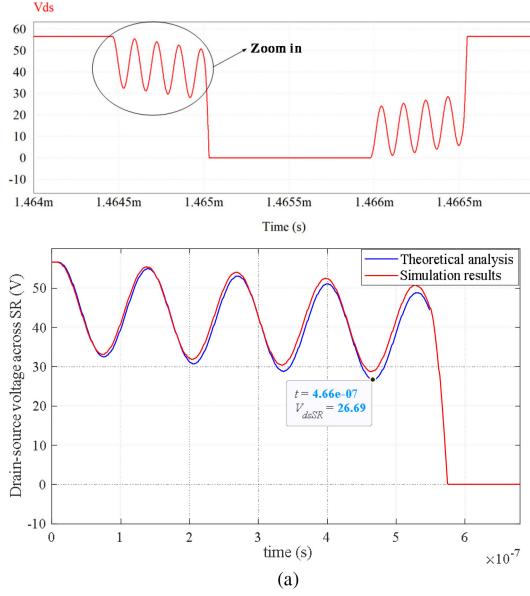

Fig. 9. Comparisons between the simulated results and the theoretical results of the voltage ringing during  $t_2$ – $t_3$ . (a) With 10 A load current. (b) With 20 A load current.

$L_r$ , the resonant capacitance  $C_r$ , the transformer turns ratio  $n$ , the parasitic output capacitance of the SR switches  $C_{oss}$ , the parasitic capacitance of the transformer  $C_p$ , the load resistance  $R_o$ , the switching frequency  $f_s$ , and the time  $t$ . Defining  $t_{zero}$  is the first time that the drain to the source voltage across SR switches reaches to zero during  $t_2$ – $t_3$ . As shown in Fig. 10, the voltage ringing starts at the end of P stage  $t_2$ , and the O stage ends when the switch  $Q_1$  is turned ON at  $t_3$ . When  $t_{zero} > t_3$ , the SR switches are not turned ON during  $t_2$ – $t_3$ . When  $t_{zero} < t_3$ , the SR switches will be turned ON early by using the voltage sensing ICs.

Thus, to avoid the turn-ON early, the condition  $t_{zero} > t_3$  is required by the optimal design of the circuit parameters. The

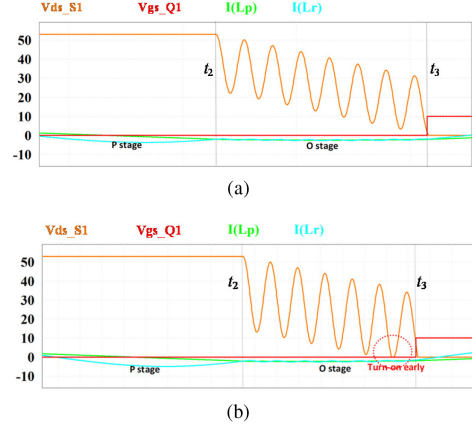

Fig. 10. First time  $t_{zero}$  that the drain-to-source voltage across SR switches reaches to zero during  $t_2$ – $t_3$ . (a)  $t_{zero} > t_3$ . (b)  $t_{zero} < t_3$ .

objective function is

$$\begin{cases} t_{zero} > t_3 \approx \frac{1}{f_s} - \frac{1}{f_r} \\ t_{zero} = \min \{v_{ds,SR2}(t - t_2) = 0\}. \end{cases} \quad (17)$$

Considering that the range of some circuit parameters is narrow in industrial applications, we define some circuit parameters as constant to simplify the complexity. Taking the datacenter application as an example, assuming that the nominal output voltage  $V_o = 54$  V, the series resonant frequency  $f_r = 500$  kHz, and the transformer turns ratio  $n = 8$ .

As PO stage is usually considered as the major preferable operation stage, the PO stage is taken as an example in this article [8]. According to [14] and (2), the state equations of the LLC converter are

$$\begin{cases} I_r P_n \sin(\theta_P + \theta_{P0}) = I_r O_n \sin(\theta_{O0}) \\ -I_r P_n \cos(\theta_P + \theta_{P0}) - 1 + \frac{1}{M} \\ = -\sqrt{m} \cdot I_r O_n \cos(\theta_{O0}) + \frac{1}{M} \\ I_r P_n \sin(\theta_{P0}) = -I_r O_n \sin\left(\frac{\theta_O}{\sqrt{m}} + \theta_{O0}\right) \\ -I_r P_n \cos(\theta_{P0}) - 1 + \frac{1}{M} \\ = \sqrt{m} \cdot I_r O_n \cos\left(\frac{\theta_O}{\sqrt{m}} + \theta_{O0}\right) - \frac{1}{M} \\ I_r P_n \sin(\theta_P + \theta_{P0}) = I_r P_n \sin(\theta_{P0}) + \frac{\theta_p}{m-1} \\ p_{on} \frac{\pi}{f_s} = I_r P_n \cos(\theta_{P0}) - I_r P_n \cos(\theta_P + \theta_{P0}) \\ - I_r P_n \sin(\theta_{P0}) \theta_P - \frac{\theta_p^2}{2(m-1)} \\ \theta_P + \theta_O = \frac{\pi}{f_s} \\ m = (L_p + L_r)/L_r \end{cases} \quad (18)$$

where  $\theta_P$  and  $\theta_O$  represent the length of P and O stage, respectively, and  $P_{ON}$  is the normalized output power;  $I_r P_n$  is the normalized magnitude of the current  $i_{Lr}$  in P stage,  $\theta_{P0}$  is the initial phase angle of  $i_{rPn}$ ;  $I_r O_n$  is the normalized magnitude of the current  $i_{Lr}$  in O stage, and  $\theta_{O0}$  is the initial phase angle.

From (18), as the voltage gain of the LLC converter can be derived by the resonant components' parameters  $L_r$ ,  $L_p$ , and  $C_r$ , the switching frequency  $f_s$ , the transformer turns ratio  $n$ , and the load resistance  $R_o$ , the input voltage can be obtained by output

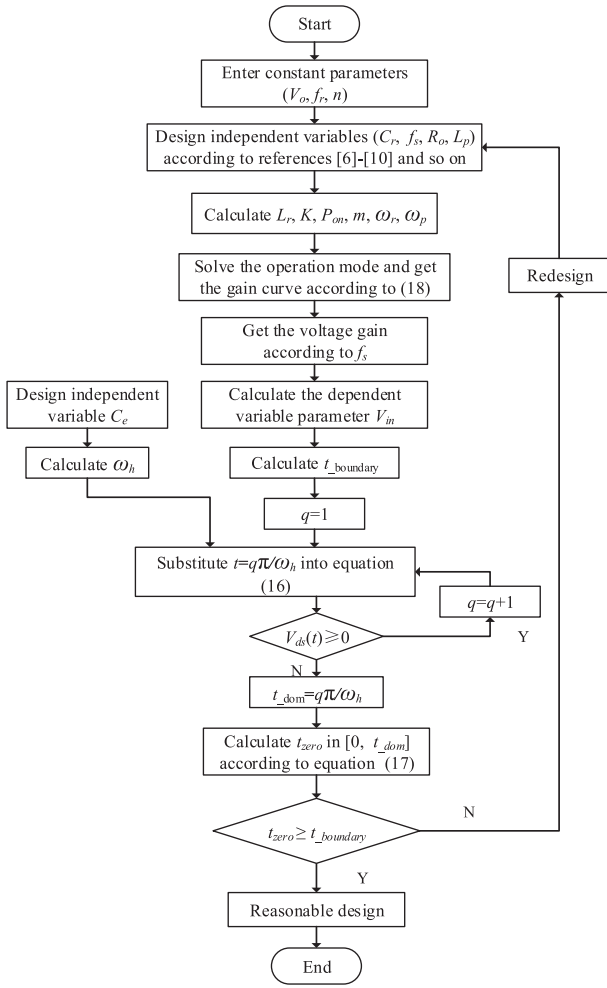

Fig. 11. Flowchart of the optimal design of the circuit parameters.

voltage and the voltage gain. Therefore, the input voltage  $V_{in}$  is not an independent variable.

The flowchart of the optimal design of the circuit parameters is shown in Fig. 11. Among the variables  $V_{in}$ ,  $V_o$ ,  $L_p$ ,  $L_r$ ,  $C_r$ ,  $C_e$ ,  $R_o$ ,  $n$ ,  $f_r$ , and  $f_s$ , some circuit parameters are selected as constant to simplify the analysis, such as  $V_o$ ,  $n$ , and  $f_r$ . Then, the variables  $L_p$ ,  $C_r$ ,  $C_e$ ,  $R_o$ , and  $f_s$  can be designed according to [6]–[10] and so on. As the variable  $L_r$  can be obtained by  $C_r$  and  $f_r$ , and  $V_{in}$  can be obtained by  $L_p$ ,  $C_r$ ,  $L_r$ ,  $R_o$ ,  $V_o$ ,  $n$ , and  $f_s$  according to (18), the  $t_{zero}$  only depends on the five independent variables  $L_p$ ,  $C_r$ ,  $C_e$ ,  $R_o$ , and  $f_s$ .

Fig. 12 shows the relationship between the  $t_{zero}$  and the five independent variables. The area above the pink surface represents a safe area, which means  $t_{zero} > t_3$  and there is no turn-ON early issue; the area below the pink surface represents an unsafe area, which means  $t_{zero} < t_3$  and the SR switches will be turned ON early by using the voltage sensing method. Points A and B located above and below the pink surface are shown in Fig. 12. The two points are very close to the pink surface; thus, the accuracy of the voltage ringing model can be verified by the simulation results of the two points in Section IV.

From Fig. 12(b), (e), (f), and (h), the voltage ringing is more and more severe along with increasing load current  $I_o$ . From Fig. 12(a), (d), (e), and (g), the voltage ringing is more and more severe along with decreasing resonant capacitance  $C_r$ . From Fig. 12(a)–(c) and (j), the voltage ringing is more and more severe along with decreasing the switching frequency  $f_s/f_r$ . According to Fig. 12(c), (d), (f), and (i), and Fig. 12(g)–(j), the resonant inductance  $L_p$  and the parasitic capacitance  $C_e$  have a relatively small effect on the voltage ringing across SR switches.

In summary, when the circuit parameters of the LLC converter are designed by using the flowchart in Fig. 11, we can relieve the voltage ringing by decreasing load current, increasing resonant capacitance, or increasing switching frequency. From Fig. 11, if the designed circuit parameters satisfy the (17), the turn-ON early issue caused by the voltage ringing can be eliminated.

## IV. SIMULATED VERIFICATION

### A. Accuracy Verification

To verify the theoretical analysis, the PSIM simulation modes of the testing points in Fig. 12 are established. As there are ten A points and ten B points in Fig. 12, if 20 figures are given in this article, too many simulated waveforms will make confusion for the reader. Therefore, only the simulation waveforms corresponding to  $t_{zero}$  against  $C_r$ ,  $R_o$ , and  $f_s$  in Fig. 12 are given in Fig. 13 because  $L_p$  and  $C_e$  have a relatively small effect on the voltage ringing across SR switches. The circuit parameters of testing points in Fig. 12(a), (b), and I are shown in Table I, and the simulation results of all the cases in Fig. 12 are given in Table II.

By using the circuit parameters, as shown in Table I, the PSIM simulation waveforms are shown in Fig. 13. From Fig. 13, although points A and B are very close, there is no turn-ON early issue in the simulation waveforms with all A points in Fig. 12(a), (b), and (e), and the SR switches are turned ON early in the simulation waveforms with all B points in Fig. 12(a), (b), and (e), which is consistent with the theoretical analysis.

To verify the accuracy of the theoretical analysis, the comparison between the calculated  $t_{zero}$  and the simulated  $t_{zero}$  is made in Table II. From Table II, the error between the calculation results in Fig. 12 and the simulation results in Fig. 12 is smaller than 0.43%, which shows that the theoretical model is very accurate. Therefore, by using the theoretical model to design the SR LLC converter with voltage sensing ICs, the turn-ON early caused by the voltage ringing will be eliminated.

### B. Simulation Verification of the Designed Prototype

From the flowchart of the optimal design of the circuit parameters in Fig. 11, taking a prototype design as an example with 350–400 V input, 54 V output, and 20 A full load. According to [6]–[10] and the proposed design procedure and the voltage ringing across SR switches calculation model, the circuit resonant parameters  $L_p = 165 \mu\text{H}$ ,  $L_r = 23.2 \mu\text{H}$ ,  $C_r = 5 \text{ nF}$ , and  $n = 25:3$  are designed. Taking the circuit parameters and the parasitic capacitance  $C_e = 7 \text{ nF}$  to (17), the testing point is located in the safe region in the calculation model. Fig. 14 shows

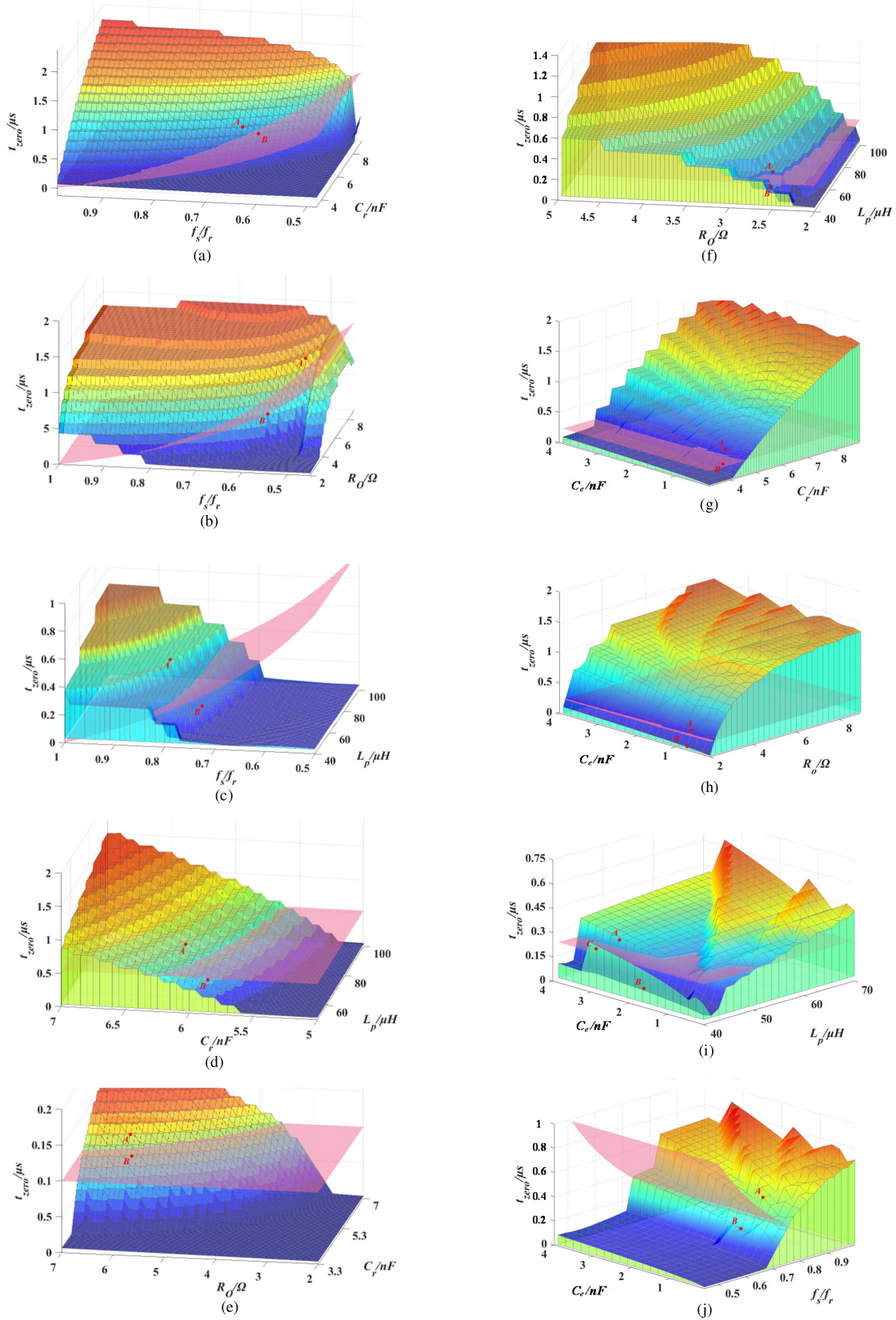

Fig. 12. Relationship between  $t_{zero}$  and the independent variables. (a)  $Cr - fs - t$  ( $L_p = 100 \mu\text{H}$ ,  $R_o = 2.43 \Omega$ , and  $C_e = 1.5 \text{ nF}$ ). (b)  $Ro - fs - t$  ( $L_p = 100 \mu\text{H}$ ,  $Cr = 5 \text{ nF}$ , and  $C_e = 1.5 \text{ nF}$ ). (c)  $Lp - fs - t$  ( $R_o = 2.43 \Omega$ ,  $Cr = 5 \text{ nF}$ , and  $C_e = 1.5 \text{ nF}$ ). (d)  $Cr - Lp - t$  ( $R_o = 2.43 \Omega$ ,  $fs/fr = 0.65$ , and  $C_e = 1.5 \text{ nF}$ ). (e)  $Cr - Ro - t$  ( $L_p = 100 \mu\text{H}$ ,  $fs/fr = 0.5$ , and  $C_e = 1.5 \text{ nF}$ ). (f)  $Lp - Ro - t$  ( $Cr = 5 \text{ nF}$ ,  $fs/fr = 0.8$ , and  $C_e = 1.5 \text{ nF}$ ). (g)  $Cr - Ce - t$  ( $L_p = 100 \mu\text{H}$ ,  $R_o = 2.43 \Omega$ , and  $fs/fr = 0.8$ ). (h)  $Ro - Ce - t$  ( $L_p = 100 \mu\text{H}$ ,  $Cr = 5 \text{ nF}$ , and  $fs/fr = 0.8$ ). (i)  $Lp - Ce - t$  ( $R_o = 2.43 \Omega$ ,  $Cr = 5 \text{ nF}$ , and  $fs/fr = 0.8$ ). (j)  $fs - Ce - t$  ( $R_o = 2.43 \Omega$ ,  $Cr = 5 \text{ nF}$ , and  $L_p = 100 \mu\text{H}$ ).

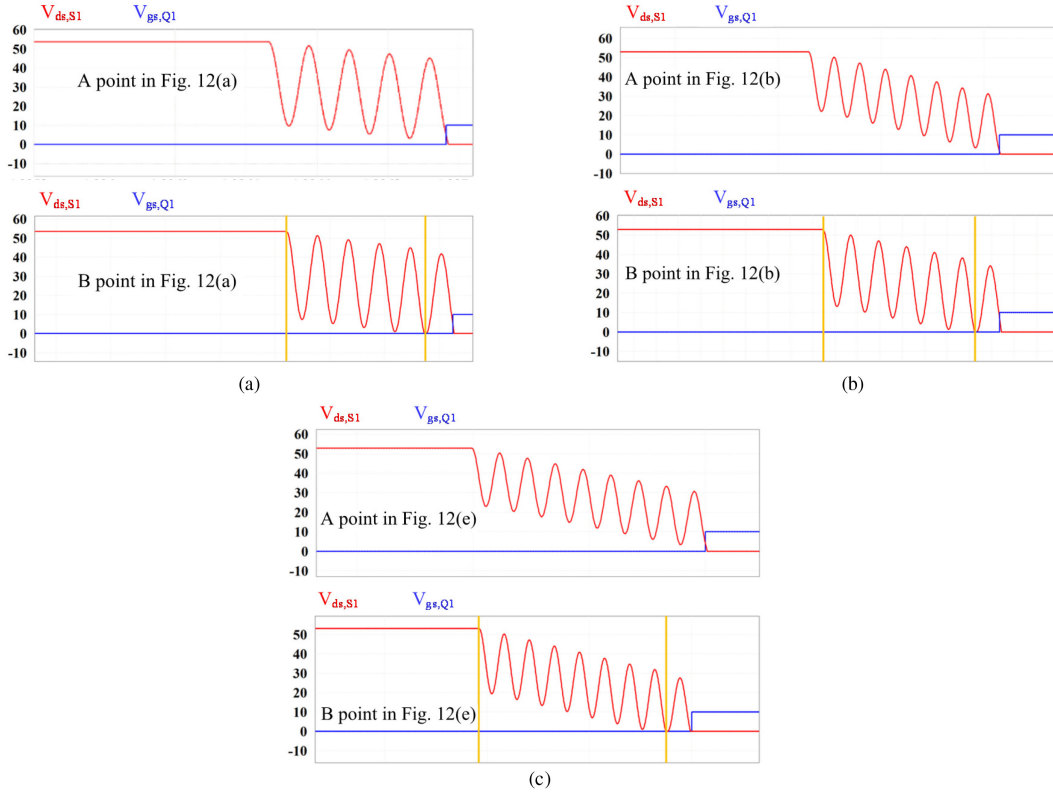

Fig. 13. PSIM simulation waveforms of the testing points in Fig. 12. (a) Simulated waveforms of the testing points in Fig. 12(a). (b) Simulated waveforms of the testing points in Fig. 12(b). (c) Simulated waveforms of the testing points in Fig. 12(e).

TABLE I  
SIMULATED MODES OF THE TESTING POINTS OF FIG. 12

Test points	Parameters	$C_r$ (nF)	$L_p$ ( $\mu$ H)	$L_r$ ( $\mu$ H)	$f_s/f_r$	$V_{in}$ (V)	$V_o$ (V)	$I_o$ (A)	$C_e$ (nF)
$C_r - f_s - t$	A (safe)	6.2	100	16.342	0.67	343.5420	54	22.2222	1.5
	B (unsafe)	6.3	100	16.083	0.63	327.7279	54	22.2222	1.5
$R_o - f_s - t$	A (safe)	5.0	100	20.264	0.52	204.7871	54	8.4375	1.5
	B (unsafe)	5.0	100	20.264	0.57	256.9875	54	12.8571	1.5
$C_r - R_o - t$	A (safe)	5.5	100	18.422	0.50	205.1445	54	8.8525	1.5
	B (unsafe)	5.2	100	19.485	0.50	195.3497	54	9.0000	1.5

the PSIM simulation waveforms of SR switches with 20 A load at 400 V input and 14 A load at 350 V input by using the designed circuit parameters. From Fig. 14, the load current is increased to 20 A at 400 V input, and the minimum value of the voltage ringing across SR switches is around 6 V. It can be seen that the drain–source voltages of SR switches are higher than zero during O stage, and the SR controller can generate the correct driving signal. From Fig. 14(b), the measured resonant period of the voltage ringing is 289 ns. Taking the circuit parameters and the parasitic capacitance  $C_e = 7$  nF to (8), the calculated resonant period of the voltage ringing is 284 ns, which is consistent with the measured value and verifies the correction and accuracy of the theoretical analysis.

By using the voltage sensing SR control strategy, this article can provide a design guideline for the high-load-current and high-output-power *LLC* converter.

## V. EXPERIMENTAL RESULTS

From the aforementioned analysis and simulated results, a two-phase interleaved *LLC* dc–dc converter is designed to verify the theoretical analysis, which consists of two paralleled *LLC* converters, as shown in Fig. 1, with 20 A rated load current for each phase. A 2.16-kW prototype with 350–400 V input and 54 V output is built according to the proposed guideline of the circuit parameters design. In the proposed prototype, the rated output current of one phase is 20 A when the input voltage is 400 V, while the output current of one phase is  $70\% \times 20$  A = 14 A when the input voltage is lower than 400 V rated input voltage. The specification and circuit parameters of the converter are shown in Table III, and the two-phase interleaved waveforms are shown in Figs. 15(b), 16, and 17.

Fig. 15(a) shows the ZVS turn-ON of switch  $Q_1$  in the phase 1 circuit, and Fig. 15(b) shows the transformer secondary currents

TABLE II  
 SIMULATED MODELS OF THE TESTING POINTS IN FIG. 12

Results		Calculation results	Simulation results	Error
		$t_{zero}(\mu s)$	$t_{zero}(\mu s)$	
$C_r - f_s - t$	B point	0.5033	0.5037	0.079%
$R_o - f_s - t$	B point	0.6778	0.6766	0.177%
$L_p - f_s - t$	B point	0.1669	0.1669	0.000%
$C_r - L_p - t$	B point	0.3618	0.3614	0.110%
$C_r - R_o - t$	B point	0.9124	0.9129	0.055%
$L_p - R_o - t$	B point	0.0555	0.0556	0.179%
$C_r - C_e - t$	B point	0.1560	0.1561	0.064%
$R_o - C_e - t$	B point	0.1866	0.1868	0.107%
$L_p - C_e - t$	B point	0.8924	0.8924	0.000%
$f_s - C_e - t$	B point	0.2100	0.2109	0.427%

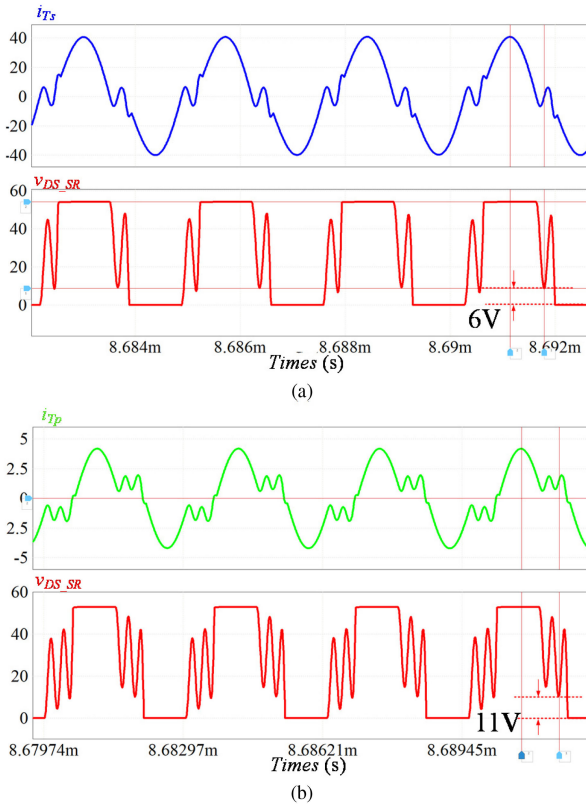
 Fig. 14. Simulation waveforms of the designed *LLC* converter at (a) 400 V input, 54 V and 20 A output, and (b) 350 V input, 54 V and 14 A output.

in phase 1 and phase 2. As shown in Fig. 15(b), by using the voltage sensing IC NCP4305, the SR gate driving signals are generated for switches  $S_1$  and  $S_2$  in the phase 1 circuit, which keeps the transformer secondary currents flowing through SR switches to reduce the conduction loss. The gate signals of transformer primary switches are shown in Fig. 15(a), and the gate signals of transformer secondary switches are shown in Fig. 15(b). From Fig. 15(b), the SR switches are turned ON properly, and there is no turn-ON early issue at full load.

 TABLE III  
 SPECIFICATIONS AND PARAMETERS OF THE PROPOSED *LLC* CONVERTER

<i>System Specification</i>	
Input voltage	350 V – 400 V
Output voltage	54 V
Rated output current	20 A×2 for two-phase converter (400 V input)
Rated output power	1080 W×2=2160 W
<i>Circuit Parameter</i>	
Transformer	$N = 25/3$ , PQ35/35 core, 3C97 material
Magnetizing inductor ( $L_m$ )	165 $\mu$ H integrated in the transformer
Series inductor ( $L_r$ )	23.2 $\mu$ H, PQ32/20 core, 3C97 material
Series capacitor ( $C_r$ )	5 nF
Parasitic capacitance ( $C_e$ )	$C_{oss, SR} = 4.9$ nF ( $V_{DS} = 54$ V) $C_p = C_e - C_{oss, SR} = 7.1$ nF – 4.9 nF = 2.2 nF
Primary-side switches	GPI65010DF56 (650 V, 10 A) × 4
Secondary-side switches	IPT012N08N5 (80 V, 300 A) × 4
Output capacitor	C3225X7R1N106K250AC, 250 V, 10 $\mu$ F × 9 + 470 $\mu$ F E-cap
Microcontroller	dsPIC33EP16GS06

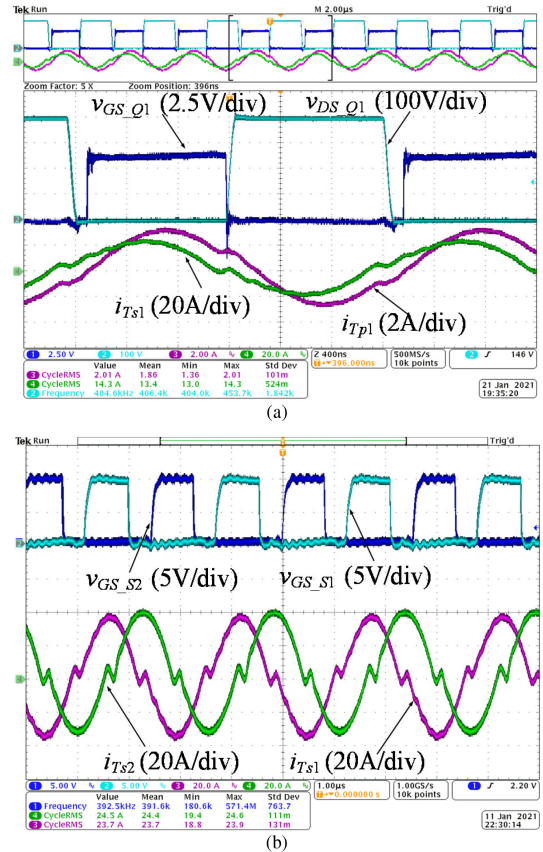
 Fig. 15. Experimental waveforms of the designed *LLC* converter at (a) 400 V input, 54 V output, and 7.5 A load current for each phase and (b) 400 V input, 54 V output, and 20 A load current for each phase.

From Fig. 12(b), (e), (f), and (h), the voltage ringing is more and more severe along with increasing load current  $I_o$ . Thus, the experimental waveforms under the rated load current are shown in Fig. 16(b). Although only 70% rated load current is provided when the input voltage is lower than 400 V, switching

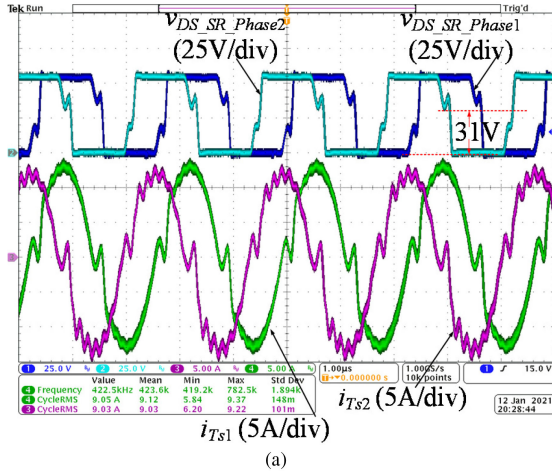

(a)

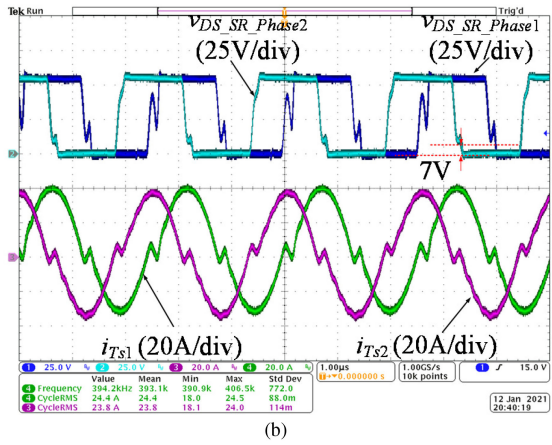

(b)

Fig. 16. Experimental waveforms of the designed LLC converter at (a) 400 V input, 54 V output, and 7.5 A load current for each phase, and (b) 400 V input, 54 V output, and 20 A load current for each phase.

frequency  $f_s$  is lower to increase voltage gain to keep 54 V output. From Fig. 12(a)–(c) and (j), the voltage ringing is more and more severe along with decreasing the switching frequency  $f_s/f_r$ . Therefore, the experimental waveforms under 70% rated load current and 350 V input are shown in Fig. 17(b) to judge which is the worst case for the voltage ringing in the proposed prototype.

Fig. 16 shows the drain-to-source voltages across the SR switches and the transformer secondary currents of phase 1 and phase 2 circuits at 400 V input and 54 V output. As shown in Fig. 16, along with the load-current increment from 7.5 to 20 A, the minimum value of the voltage ringing across SR switches is changed from 31 to 7 V, which verifies the analysis in which the voltage ringing is more and more severe along with increasing load current. According to Fig. 16, if the load current is increased further, the voltage ringing would reach to zero and the converter operates at unsafe region. By substituting the circuit parameters in [10] and [34] to (17), the calculation results show the converters operate at unsafe region, which are consistent with the experimental results of the safe region and unsafe region in [10] and [34].

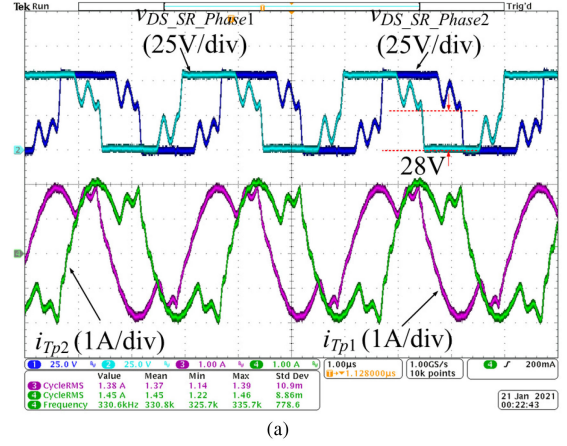

(a)

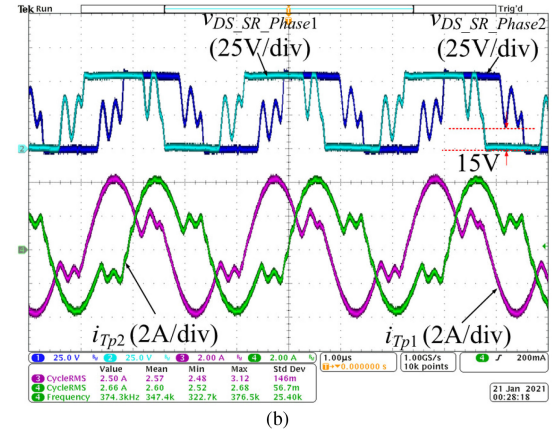

(b)

Fig. 17. Experimental waveforms of the designed LLC converter at (a) 350 V input, 54 V output, and 7.5 A load current for each phase, and (b) 350 V input, 54 V output, and 14 A load current for each phase.

Fig. 17 shows the drain-to-source voltages across the SR switches and the transformer primary-side currents of the two-phase LLC converters at 350 V input and 54 V output. When the load current is 7.5 A and 14 A load current for each phase, the minimum values of the  $v_{ds}$  are 28 V and 15 V, respectively. From Fig. 16(a) and 17(a), at the same load current, the minimum value of the voltage ringing across SR switches is changed from 31 to 28 V when the switching frequency is changed from 423 to 331 kHz, which verifies the analysis in which the voltage ringing is more and more severe along with decreasing switching frequency.

From Figs. 16 and 17, the load resistance  $R_o$  has a larger effect than the switching frequency  $f_s$  on the voltage ringing across SR switches. Therefore, the worst condition of the proposed prototype for the voltage ringing is 400 V input and 20 A load current. From Figs. 16(b) and 17(b), the experimental results are consistent with the simulated results in Fig. 14, which verifies the correctness and effectiveness of the analysis.

As shown in the experimental results in Fig. 17(b), the resonant period of the voltage ringing is measured as 287 ns, and thus,  $C_e$  is 7.1 nF in the prototype according to (8). From the datasheet of the SR switches, the equivalent output capacitance  $C_{oss, SR}$  is around 4.9 nF when the output voltage is 54 V. Therefore, we can

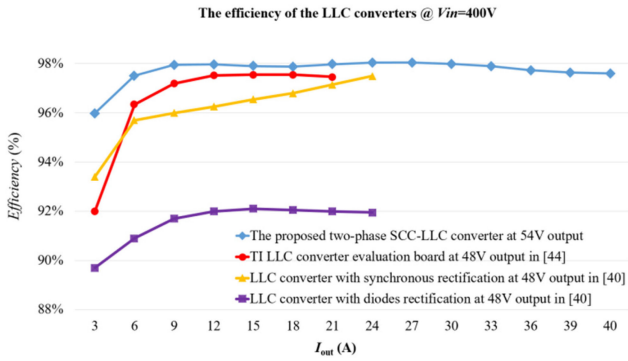

Fig. 18. Efficiency comparison between the designed *LLC* converter and the previous works.

calculate that the transformer secondary parasitic capacitance  $C_p$  is 2.2 nF.

At light load, the current ringing, as shown in Figs. 16(a) and 17(a), is caused by the parasitic parameters, such as the parasitic capacitance of the series resonant inductor, the parasitic capacitance of the transformer, and the leakage inductance of the transformer. At high load, the current ringing is not obvious in Figs. 16(b) and 17(b). As the severe voltage ringing generally occurs at high load instead of light load, these parasitic parameters are not analyzed in this article to simplify the complexity of the voltage ringing model.

As the circuit parameters  $C_r$ ,  $L_p$ ,  $C_e$ , etc., have a tolerance between the two circuits, the two-phase waveforms are not very the same exactly. As the difference between the two-phase waveforms is small and the theoretical analysis in this article can be verified by Figs. 15–17, the tolerance is neglected in this article.

In the designed *LLC* converter, phase shedding technology is adopted to improve light-load efficiency, and a 20 A load current is provided by each phase at full load. The blue line in Fig. 18 shows the measured efficiency of the designed two-phase *LLC* dc–dc converter. By using the voltage sensing SR controller and the circuit parameters according to the proposed design guideline, the peak efficiency of the prototype reaches 98.1%, and the full load efficiency is 97.6%. In Fig. 18, the efficiency of the prototype is compared between this work and the previous works with a similar specification. The red and yellow lines represent the measured efficiency of the *LLC* converter with SR in [44] and [40], and the purple line represents the measured efficiency of the *LLC* converter with diodes rectification in [40]. From Fig. 18, the efficiency of the proposed prototype is high, which verifies the effectiveness of the proposed design principle of the *LLC* converter. Fig. 19 shows the prototype of the *LLC* converter.

## VI. CONCLUSION

Voltage sensing SR control strategy is used widely in high-load-current *LLC* dc–dc converter in industrial applications. This article presents the accurate analysis and design of the circuit parameters of SR *LLC* dc–dc converter, which can avoid voltage ringing across SR switches reaches to zero and make voltage

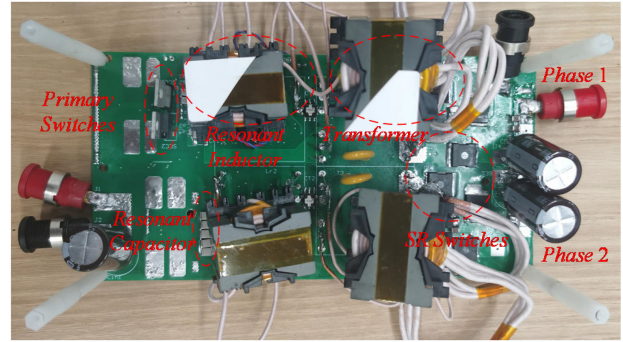

Fig. 19. Prototype of the *LLC* converter.

sensing SR controller generate false driving pulses. By using the proposed parameters design principle and the voltage ringing across SR switches calculation model, the SR switches turn-ON early issue or the SR switches turn-ON several times in one cycle issue is eliminated, which guarantees that the voltage sensing SR ICs work well. Therefore, the proposed analysis of the voltage ringing across SR switches and the parameters design principle can provide a reference and guideline for the high-load-current and high-output-power *LLC* converter with the voltage sensing SR control strategy.

## REFERENCES

- [1] B. Yang, F. C. Lee, A. J. Zhang, and G. Huang, "LLC resonant converter for front end DC/DC conversion," in *Proc. 17th Annu. IEEE Appl. Power Electron. Conf. Expo.*, Dallas, TX, USA, 2002, vol. 2, pp. 1108–1112.
- [2] O. Yu, C.-W. Chen, C.-S. Yeh, and J.-S. Lai, "Drain-source synchronous rectifier oscillation mitigation in light-load conditions," *IEEE Open J. Power Electron.*, vol. 1, pp. 14–23, 2020.
- [3] K.-B. Park, B.-H. Lee, G.-W. Moon, and M.-J. Youn, "Analysis on center-tap rectifier voltage oscillation of LLC resonant converter," *IEEE Trans. Power Electron.*, vol. 27, no. 6, pp. 2684–2689, Jun. 2012.
- [4] J.-W. Kim, M.-H. Park, B.-H. Lee, and J.-S. Lai, "Analysis and design of LLC converter considering output voltage regulation under no-load condition," *IEEE Trans. Power Electron.*, vol. 35, no. 1, pp. 522–534, Jan. 2020.
- [5] X. Wu and H. Shi, "High efficiency high density 1 MHz 380–12V DCX with low FoM devices," *IEEE Trans. Ind. Electron.*, vol. 67, no. 2, pp. 1648–1656, Feb. 2020.
- [6] Y. Wei, Q. Luo, X. Du, N. Altin, J. M. Alonso, and H. A. Mantooh, "Analysis and design of the LLC resonant converter with variable inductor control based on time-domain analysis," *IEEE Trans. Ind. Electron.*, vol. 67, no. 7, pp. 5432–5443, Jul. 2020.
- [7] J. Liu, J. Zhang, T. Q. Zheng, and J. Yang, "A modified gain model and the corresponding design method for an LLC resonant converter," *IEEE Trans. Power Electron.*, vol. 32, no. 9, pp. 6716–6727, Sep. 2017.
- [8] X. Fang et al., "Efficiency-oriented optimal design of the LLC resonant converter based on peak gain placement," *IEEE Trans. Power Electron.*, vol. 28, no. 5, pp. 2285–2296, May 2013.
- [9] Y. Wei, Q. Luo, Z. Wang, and H. A. Mantooh, "A complete step-by-step optimal design for LLC resonant converter," *IEEE Trans. Power Electron.*, vol. 36, no. 4, pp. 3674–3691, Apr. 2021.
- [10] R. Beiranvand, B. Rashidian, M. R. Zolghadri, and S. M. H. Alavi, "A design procedure for optimizing the LLC resonant converter as a wide output range voltage source," *IEEE Trans. Power Electron.*, vol. 27, no. 8, pp. 3749–3763, Aug. 2012.
- [11] X. Zhou et al., "A high-efficiency high-power-density on-board low-voltage dc-dc converter for electric vehicles application," *IEEE Trans. Power Electron.*, vol. 36, no. 11, pp. 12781–12794, Nov. 2021.
- [12] E. S. Glitz, J.-D. Hsu, and M. Ordóñez, "Power loss estimation in LLC synchronous rectification using rectifier current equations," *IEEE Trans. Ind. Electron.*, vol. 67, no. 5, pp. 3696–3704, May 2020.

- [13] Y. Wei, Q. Luo, and H. A. Mantooth, "Synchronous rectification for LLC resonant converter: An overview," *IEEE Trans. Power Electron.*, vol. 36, no. 6, pp. 7264–7280, Jun. 2021.
- [14] X. Fang, H. Hu, Z. J. Shen, and I. Batarseh, "Operation mode analysis and peak gain approximation of the LLC resonant converter," *IEEE Trans. Power Electron.*, vol. 27, no. 4, pp. 1985–1995, Apr. 2012.
- [15] X. Zhu et al., "A sensorless model-based digital driving scheme for synchronous rectification in 1-kV input 1-MHz GaN LLC converters," *IEEE Trans. Power Electron.*, vol. 36, no. 7, pp. 8359–8369, Jul. 2021.
- [16] J. Zhang, J. Liao, J. Wang, and Z. Qian, "A current-driving synchronous rectifier for an LLC resonant converter with voltage-doubler rectifier structure," *IEEE Trans. Power Electron.*, vol. 27, no. 4, pp. 1894–1904, Apr. 2012.
- [17] X. Wu, G. Hua, J. Zhang, and Z. Qian, "A new current-driven synchronous rectifier for series-parallel resonant LLC DC-DC converter," *IEEE Trans. Ind. Electron.*, vol. 58, no. 1, pp. 289–297, Jan. 2011.
- [18] B.-C. Kim, H.-S. Park, S. C. Moon, Y.-D. Kim, D.-Y. Kim, and G.-W. Moon, "The novel synchronous rectifier driving method for LLC series resonant converter," in *Proc. 38th Annu. Conf. IEEE Ind. Electron. Soc.*, 2012, pp. 810–813.
- [19] H. Yu, X. Xie, S. Xu, and H. Dong, "A novel synchronous rectifier driving scheme for LLC converter based on secondary rectification current emulation," *IEEE Trans. Power Electron.*, vol. 37, no. 4, pp. 3825–3835, Apr. 2022.
- [20] K. Wang, G. Wei, J. Wei, J. Wu, L. Wang, and X. Yang, "Current detection and control of synchronous rectifier in high-frequency LLC resonant converter," *IEEE Trans. Power Electron.*, vol. 37, no. 4, pp. 3691–3696, Apr. 2022.
- [21] J. Wang and B. Lu, "Open loop synchronous rectifier driver for LLC resonant converter," in *Proc. 28th Annu. IEEE Appl. Power Electron. Conf. Expo.*, 2013, pp. 2048–2051.
- [22] D. Wang and Y.-F. Liu, "A zero-crossing noise filter for driving synchronous rectifiers of LLC resonant converter," *IEEE Trans. Power Electron.*, vol. 29, no. 4, pp. 1953–1965, Apr. 2014.
- [23] D. Fu, Y. Liu, F. C. Lee, and M. Xu, "A novel driving scheme for synchronous rectifiers in LLC resonant converters," *IEEE Trans. Power Electron.*, vol. 24, no. 5, pp. 1321–1329, May 2009.
- [24] L. He, J. Chen, B. Cheng, and H. Zhou, "Duty cycle loss compensation method based on magnetic flux cancelation in high-current high-frequency synchronous rectifier of LCLC converter," *IEEE Trans. Power Electron.*, vol. 36, no. 1, pp. 103–113, Jan. 2021.
- [25] W. Feng, F. C. Lee, P. Mattavelli, and D. Huang, "A universal adaptive driving scheme for synchronous rectification in LLC resonant converters," *IEEE Trans. Power Electron.*, vol. 27, no. 8, pp. 3775–3781, Aug. 2012.
- [26] C. Fei, Q. Li, and F. C. Lee, "Digital implementation of adaptive synchronous rectifier (SR) driving scheme for high-frequency LLC converters with microcontroller," *IEEE Trans. Power Electron.*, vol. 33, no. 6, pp. 5351–5361, Jun. 2018.
- [27] P. Amiri, C. Botting, M. Craciun, W. Eberle, and L. Wang, "Analytic-adaptive LLC resonant converter synchronous rectifier control," *IEEE Trans. Power Electron.*, vol. 36, no. 5, pp. 5941–5953, May 2021.
- [28] J.-D. Hsu, M. Ordonez, W. Eberle, M. Craciun, and C. Botting, "LLC synchronous rectification using resonant capacitor voltage," *IEEE Trans. Power Electron.*, vol. 34, no. 11, pp. 10970–10987, Nov. 2019.
- [29] X. Ren, L. Pei, S. Song, J. Zhang, Y. Pei, and L. Wang, "A digital sensor-less synchronous rectification algorithm for symmetrical bidirectional CLLC resonant converters," in *Proc. IEEE Appl. Power Electron. Conf. Expo.*, 2020, pp. 962–968.
- [30] H. Li et al., "Bidirectional synchronous rectification on-line calculation control for high voltage applications in SiC bidirectional LLC portable chargers," *IEEE Trans. Power Electron.*, vol. 36, no. 5, pp. 5557–5568, May 2021.
- [31] H. Chen, K. Sun, H. Shi, J.-I. Ha, and S. Lee, "A battery charging method with natural synchronous rectification features for full-bridge CLLC converters," *IEEE Trans. Power Electron.*, vol. 37, no. 2, pp. 2139–2151, Feb. 2022.
- [32] H. Li et al., "An impedance-based digital synchronous rectifier driving scheme for bidirectional high-voltage SiC LLC converter," *IEEE Trans. Ind. Electron.*, vol. 69, no. 11, pp. 11314–11323, Nov. 2022.
- [33] L. Pei et al., "A time-domain-model-based digital synchronous rectification algorithm for CLLC resonant converters utilizing a hybrid modulation," *IEEE Trans. Power Electron.*, vol. 37, no. 3, pp. 2815–2829, Mar. 2022.
- [34] T. Jiang, J. Zhang, X. Wu, K. Sheng, and Y. Wang, "A bidirectional LLC resonant converter with automatic forward and backward mode transition," *IEEE Trans. Power Electron.*, vol. 30, no. 2, pp. 757–770, Feb. 2015.
- [35] J. Xu et al., "PWM modulation and control strategy for LLC-DCX converter to achieve bidirectional power flow in facing with resonant parameters variation," *IEEE Access*, vol. 7, pp. 54693–54704, 2019.
- [36] S. Moon, C. Chen, and R.-J. Wang, "A new dead time regulation synchronous rectification control method for high efficiency LLC resonant converters," *IEEE Trans. Power Electron.*, vol. 36, no. 9, pp. 10673–10683, Sep. 2021.
- [37] C.-E. Kim, "Minimization of abnormal output voltage rising for LLC resonant converter at very light load," *IEEE Trans. Ind. Electron.*, vol. 67, no. 12, pp. 10295–10303, Dec. 2020.
- [38] K.-W. Kim, H.-S. Youn, J.-I. Baek, Y. Jeong, and G.-W. Moon, "Analysis on synchronous rectifier control to improve regulation capability of high-frequency LLC resonant converter," *IEEE Trans. Power Electron.*, vol. 33, no. 8, pp. 7252–7259, Aug. 2018.
- [39] X. Zhou et al., "Analysis and design of SR driver circuit for LLC dc-dc converter under high load current application," in *Proc. IEEE Energy Convers. Congr. Expo.*, 2019, pp. 1375–1381.
- [40] M. Mohammadi and M. Ordonez, "Synchronous rectification of LLC resonant converters using homopolarity cycle modulation," *IEEE Trans. Ind. Electron.*, vol. 66, no. 3, pp. 1781–1790, Mar. 2019.
- [41] N. Chen et al., "Synchronous rectification based on resonant inductor voltage for CLLC bidirectional converter," *IEEE Trans. Power Electron.*, vol. 37, no. 1, pp. 547–561, Jan. 2022.
- [42] On semiconductor. Datasheet\_NCP4318, 2021. [Online]. Available: <https://www.onsemi.com/pdf/datasheet/ncp4318-d.pdf>
- [43] G. Ivensky, S. Bronshtein, and A. Abramovitz, "Approximate analysis of resonant LLC dc-dc converter," *IEEE Trans. Power Electron.*, vol. 26, no. 11, pp. 3274–3284, Nov. 2011.
- [44] TI, "PMP20637 RevA test report," Dallas, TX, USA, May 2017. [Online]. Available: <https://www.ti.com>



**Xiang Zhou** (Member, IEEE) received the B.S. and Ph.D. degrees in electrical engineering from Southwest Jiaotong University, Chengdu, China, in 2013 and 2018, respectively.

From June 2018 to December 2019, he was with the Department of Electrical and Computer Engineering, Queen's University, Kingston, ON, Canada, as a Postdoctoral Research Fellow. Since 2019, he has been with Xi'an Jiaotong University, Xi'an, China, where he is currently an Assistant Professor with the School of Electrical Engineering. His current research

interests include soft switching dc-dc converter and dc-ac converter topology and control, resonant converters and server power supplies, and EV chargers.



**Laili Wang** (Senior Member, IEEE) received the B.S., M.S., and Ph.D. degrees from the School of Electrical Engineering, Xi'an Jiaotong University, Xi'an, China, in 2004, 2007, and 2011, respectively.

Since 2011, he has been a Postdoctoral Research Fellow with the Department of Electrical Engineering, Queen's University, Kingston, ON, Canada. From 2014 to 2017, he was an Electrical Engineer with Sumida, Kingston, ON, Canada. In 2017, he became a Full Professor of Xi'an Jiaotong University. His research interests include Wide Bandgap Power Devices, Package and Integration, High Density Power Conversion, Wireless Power Transfer, and Energy Harvesting. He is the recipient of Outstanding Youth Award from China Power Supply Society (CPSS), China Electric Power Excellent Young Technological Talent Award from Chinese Society of Electrical Engineering (CSEE), Gold Medal Award of Geneva Inventions.

Dr. Wang is currently an Associate Editor for IEEE TRANSACTIONS ON POWER ELECTRONICS and IEEE JOURNAL OF EMERGING AND SELECTED TOPICS IN POWER ELECTRONICS. He is the Co-Chair of System Integration and Application in International Technology Roadmap for Wide Band-Gap Power Semiconductor (ITRW), and the Chair of CPSS and IEEE PELS Joint Chapter in Xi'an, China.



**Yongmei Gan** (Member, IEEE) was born in 1971. She received the B.S. degree and the M.S. degree in control engineering from the Xi'an University of Technology, Xi'an, China, in 1993 and 1996, respectively, and the Ph.D. degree in control theory and control engineering from Northwestern Polytechnical University, Xi'an, China, in 1999.

Since 2000, she has been with the School of Electrical Engineering, Xi'an Jiaotong University, Xi'an, China, where she is currently an Associate Professor.

From February 2008 to February 2009, she was a Visiting Scholar with the Department of Electrical and Computer Engineering, University of Toronto. Her research interests include package and integration of wide-bandgap power semiconductor devices, energy harvesting, and supervisory control of discrete-event systems.



**Huan Luo** (Member, IEEE) was born in Sichuan, China, in 1990. He received the B.S. degree in electrical engineering from Southwest Jiaotong University, Chengdu, China, in 2012, the M.S. degree in power system from Sichuan University, Chengdu, China, in 2015, and the Ph.D. degree in electrical engineering from Southwest Jiaotong University, Chengdu, China, in 2018.

He is currently a Lecturer with Sichuan University. His research interests include the control technique of switching-mode power supplies, single-phase power

factor correction, and renewable power system.



**Yan-Fei Liu** (Fellow, IEEE) received the Bachelor's and Master's degrees from the Department of Electrical Engineering, Zhejiang University, Hangzhou, China, in 1984 and 1987, respectively, and the Ph.D. degree from the Department of Electrical and Computer Engineering, Queen's University, Kingston, ON, Canada, in 1994.

He was a Technical Advisor with Advanced Power System Division, Nortel Networks, Ottawa, Canada, from 1994 to 1999. Since 1999, he has been with Queen's University, where he is currently a Professor

with the Department of Electrical and Computer Engineering. His current research interests include optimal application of GaN and SiC devices to achieve small-size and high-efficiency power conversion, 99% efficiency power conversion with extremely high power density, digital control technologies for high efficiency, fast dynamic response dc–dc switching converter and ac–dc converter with power factor correction, resonant converters and server power supplies, and LED drivers. He has authored around 250 technical papers in IEEE Transactions and Conferences and holds 35 U.S. patents. He has written a book on “High Frequency MOSFET Gate Drivers: Technologies and Applications,” published by IET. He is also a Principal Contributor for two IEEE standards.

Dr. Liu was a recipient of “Modeling and Control Achievement Award” from IEEE Power Electronics Society in 2017, Premier's Research Excellence Award in 2000 in Ontario, Canada, and the Award of Excellence in Technology in Nortel in 1997. He was the Vice President of Technical Operations of IEEE Power Electronics Society (PELS, from 2017 to 2020). He has been serving as an Editor for IEEE JOURNAL OF EMERGING AND SELECTED TOPICS OF POWER ELECTRONICS (IEEE JESTPE) since 2013. He was the General Chair of ECCE 2019 held in Baltimore, USA, in 2019. His major service to IEEE is listed below: a Guest Editor-in-Chief for the special issue of Power Supply on Chip of IEEE TRANSACTIONS ON POWER ELECTRONICS from 2011 to 2013; a Guest Editor for special issues of JESTPE: Miniaturization of Power Electronics Systems in 2014 and Green Power Supplies in 2016; as a Co-General Chair of ECCE 2015 held in Montreal, Canada, in September 2015; the Chair of PELS Technical Committee (TC1) on Control and Modeling Core Technologies, from 2013 to 2016; and the Chair of PELS Technical Committee (TC2) on Power Conversion Systems and Components, from 2009 to 2012.



**Paresh C. Sen** (Life Fellow, IEEE) was born in Chittagong, Bangladesh. He received the B.Sc. (with honors in physics) and M.Sc. (tech.) degrees in applied physics from the University of Calcutta, Kolkata, India, in 1958 and 1962, respectively, and the M.A.Sc. and Ph.D. degrees in electrical engineering from the University of Toronto, Toronto, ON, Canada, in 1965 and 1967, respectively.

He is currently an Emeritus Professor of electrical and computer engineering with Queen's University, Kingston, ON, Canada. He has worked for industries in India and Canada and was a consultant to electrical industries in Canada. He has authored more than 215 technical papers in the general area of electric motor drives and power electronics. He is the author of two internationally acclaimed textbooks: *Principles of Electric Machines and Power Electronics* (Wiley 1989, 1997, and 2013) and *Thyristor DC Drives* (Wiley 1981). He has taught electric machines, power electronics, and electric drive systems for more than 45 years. His fields of interest include power electronics, electric drive systems, switching power supplies, wind energy systems, digital control, and modern control techniques for power electronics and motor drive systems.

Dr. Sen was a recipient of the IEEE-IAS (Industry Application Society) Outstanding Achievement Award in 2008, the IEEE-Canada Outstanding Engineering Educator Award in 2006 for his outstanding contributions over four decades as a Researcher, Supervisor, Teacher, Author, and Consultant, and the IAS-IDC Prize Paper Award in 1986. He has served IEEE in various capacities: as an Associate Editor, Distinguished Lecturer, Chairman of the Technical Committees on Power Electronics and Energy Systems, Session Organizer, Session Chairperson, and Paper Reviewer. He served as Natural Science and Engineering Research Council of Canada Scientific Liaison Officer evaluating university-industry coordinated projects. He is globally recognized as an authority in power electronics and motor drive systems. He is a fellow of EIC. As an Emeritus Professor, he continues to be active in research, supervision of graduate students, and in several IEEE societies.