

A Grid Inductance Detection Method Based on the Oscillation Characteristic of Inverter Terminal Voltage

Shuangming Duan , Member, IEEE, Bo Xia, Gangui Yan , Member, IEEE, Nan Li, Gen Li , Member, IEEE, and Yi Ding

Abstract—In grid-connected photovoltaic (PV) systems, grid inductance greatly influences the performance of grid-connected inverters. However, the grid inductance usually varies with the changes of the grid operation conditions. Therefore, accurate grid inductance detection is one of the key technologies to achieve an adaptive control of the grid-connected inverters under different operation conditions. In this article, an equivalent circuit model of a grid-connected PV system which includes the controller, filter, and grid impedance is established. The oscillation characteristic of the inverter terminal voltage caused by the sudden change of the inverter output power is analyzed. The oscillation mechanism of the inverter terminal voltage caused by the interaction of the controller, filter, and grid impedance is investigated. A grid inductance detection method based on the oscillation characteristic of the inverter terminal voltage is proposed. The main advantage of the proposed method is that it does not need complicated signal processing and calculation procedures. A 10-kW grid-connected PV system was built for both simulations and the experimental setup. Finally, simulation and experimental results validate the correctness and effectiveness of the proposed method.

Index Terms—Grid-connected photovoltaic (PV) systems, grid inductance detection, photovoltaic (PV) inverter, power sudden change, terminal voltage oscillation.

I. INTRODUCTION

WITH the increasing consumption of fossil fuels such as coal, oil, and natural gas, environmental problems have become increasingly serious. Distributed power generation technologies that utilize renewable energy to generate power

have developed rapidly. The grid-connected inverters are the interfaces of the photovoltaic (PV) systems [1]–[3]. Considering that the grid-connected PV systems are distributed in the power grid, a large number of transformers and long transmission lines are required to access them to the grid, resulting in a very large grid impedance in the grid. Moreover, the change of the grid operation conditions may also lead to a big change of the grid impedance [4]. However, the grid inductance may greatly affect the control performance of grid-connected inverters as well as the stability of grid-connected PV systems [5], [6]. To achieve an adaptive control of grid-connected inverters under different operation conditions, the grid inductance detection is of a great importance to provide a reference for the adjustment of the control parameters of grid-connected inverters [7]–[10].

At present, the methods for grid inductance detection are generally divided into passive (noninvasive) and active (invasive) [11]. Active methods deliberately create a disturbance in a grid and then the grid inductance can be estimated based on the grid responses. Active methods generally inject disturbance signals into the system, where the injected disturbance signals can be 1) single frequency at 75 Hz [7], [12], [13] and 600 Hz [14]; and 2) dual frequencies at 400 and 600 Hz [14]. Then, based on the current and voltage responses to this disturbance at point of common coupling (PCC), the grid inductance can be estimated through Fourier analysis. To solve the shortcoming that these approaches only estimate the grid inductance at some specific frequencies, more spectrum information can be acquired by injecting pulse signals [15]. Roinila *et al.* [16] and Riccobono *et al.* [17] presented an approach by injecting pulse signals to estimate the grid inductance. Moreover, Neshvad *et al.* [18] proposed a method using pseudo-random-binary signals instead of pulse signals, which overcomes the shortcoming of the low detection accuracy when pulse signals are used to estimate grid inductance. For grid inductance detection of three-phase grid-connected inverters using *PQ* control, a disturbance is added to the references of active and reactive power, then grid inductance can be typically estimated by measuring voltage and current disturbances of two different operation points [19]–[23]. However, these methods are all carried out through injecting disturbance signals in a grid, and the grid inductance is detected based on the grid responses. Moreover, the disturbance signals may have an adverse effect on the output power quality and the stability of the grid-connected systems.

Manuscript received March 10, 2021; revised July 7, 2021 and October 5, 2021; accepted December 23, 2021. Date of publication January 4, 2022; date of current version February 18, 2022. This work was supported in part by the Science and Technology Development Plan Program of Jilin, China, under Grant 20200201198JC and in part by the Integrated Project of National Natural Science Foundation of China under Grant U1866601. Recommended for publication by Associate Editor T. Qian. (Corresponding author: Gangui Yan.)

Shuangming Duan, Bo Xia, Gangui Yan, and Yi Ding are with the Key Laboratory of Modern Power System Simulation and Control & Renewable Energy Technology, Ministry of Education, Northeast Electric Power University, Jilin 132012, China (e-mail: 33339371@163.com; xiab96820@163.com; yangg@neepu.edu.cn; dy354270443@163.com).

Nan Li is with the State Grid Liaoning Extra High Voltage Company, Shenyang 110000, China (e-mail: 15526950008@163.com).

Gen Li is with the School of Electrical Engineering, Cardiff University, CF10 3AT Cardiff, U.K. (e-mail: lig9@cardiff.ac.uk).

Color versions of one or more figures in this article are available at <https://doi.org/10.1109/TPEL.2021.3139886>.

Digital Object Identifier 10.1109/TPEL.2021.3139886

Different from active methods, passive methods use the non-characteristic harmonic voltage and current measurements inherently presented in the grid-connected systems to estimate the grid inductance [24]. Therefore, passive methods do not produce negative impact in the output power quality and the stability of grid-connected systems. Such methods have drawn extensive attention from researchers. But in most cases, this method may fail to provide accurate estimations [25]. Cobreces *et al.* [26] proposed a method based on a recursive least-squares algorithm to estimate the grid inductance. The structure and control algorithm of an inverter are not involved in modeling process, which may have a potential for wide applications. However, this method involves a huge burden of calculations and the shortcoming of low accuracy. One approach estimates the grid inductance via the excitation and detection of LCL filter resonances [27]. However, such a method may be unsecure due to the resonance amplification. In [28], the extended Kalman Filter proves to be beneficial to estimate the grid inductance. Moreover, this method can be a promising tool for estimating the grid inductance. However, the extended Kalman Filter is complicated due to the large system state-space models and Jacobian Matrix calculation. The tuning of noise covariance matrices (including the measurement and process covariance matrices) is difficult as well, especially when there are a huge number of states. In practice, the tuning is often a trial-and-error procedure [29]. Therefore, this method requires a system model simplification, which may reduce the accuracy of the model. In [30], an impedance identification scheme for three-phase balanced voltage source inverter based on the transient response of the inverter. However, the scheme is only designed to present an identification procedure of the impedance of the inverter with capacitive output. In [31], an inductance identification method based on the evaluation of the closed-loop transient of dq -axis is proposed. However, this method needs complicated iterative processes.

In this article, a passive online detection method of grid inductance based on the transient response of inverter terminal voltage is proposed. This method does not need complicated signal processing and calculation procedures.

The rest of this article is organized as follows. An equivalent circuit model of a grid-connected PV system is established, and the mechanism of the interaction of the controller, filter, and grid impedance is investigated in Section II. In Section III, the oscillation characteristic of the inverter terminal voltage caused by the sudden changes of the inverter output power is analyzed, and a grid inductance detection method based on the oscillation characteristic of the inverter terminal voltage is proposed. In Sections IV and V, the correctness and effectiveness of the proposed method are verified by simulations in PSCAD/EMTDC and validated through experiments. Finally, Section VI concludes this article.

II. ANALYTICAL MODEL OF THE GRID-CONNECTED INVERTER TERMINAL VOLTAGE

Fig. 1 describes an LC -type grid-connected PV system. L_1 and C_1 are the filter inductance and the filter capacitance, respectively. L_2 is the common mode inductance. As a common

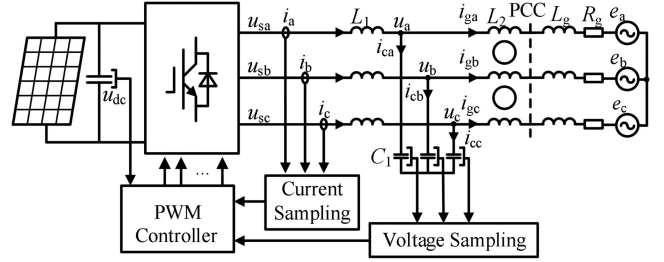

Fig. 1. Schematic diagram of a grid-connected PV system.

practice, we model the grid as a series connection of resistance R_g , inductance L_g , and voltage sources e_x [22], [28]. u_{dc} is the dc bus voltage. u_{sx} and i_x are output voltage and output current of the inverter, respectively. i_{gx} is the grid side current. u_x is the filter capacitance voltage of the inverter ($x = a, b, c$), which is called inverter terminal voltage in this article. PCC denotes the coupling point between the inverter and the grid.

In the synchronous rotation reference frame (Park transformation), the circuit equations of the grid-connected PV system in Fig. 1 are given in the following equations. Generally, the d -axis of the synchronous rotation reference frame coincides with the terminal voltage vector. The q -axis lags the d -axis by 90° . i_d is the current component of the d -axis, and defined as the active current. i_q is the current component of the q -axis, and defined as the reactive current

$$\begin{cases} i_d = -\omega_1 C_1 u_q + C_1 \frac{du_d}{dt} + i_{dg} \\ i_q = \omega_1 C_1 U_d + C_1 \frac{du_q}{dt} + i_{qg} \end{cases} \quad (1)$$

$$\begin{cases} u_{sd} = -\omega_1 L_1 i_q + L_1 \frac{di_d}{dt} + u_d \\ u_{sq} = \omega_1 L_1 i_d + L_1 \frac{di_q}{dt} + u_q \end{cases} \quad (2)$$

$$\begin{cases} u_d = -\omega_1 L_2 i_{qg} + L_2 \frac{di_{dg}}{dt} + R_g i_{dg} + e_d \\ u_q = \omega_1 L_2 i_{dg} + L_2 \frac{di_{qg}}{dt} + R_g i_{qg} + e_q \\ L_2 = L_1 + L_g \end{cases} \quad (3)$$

where u_{sd} and u_{sq} are the dq -axis components of u_{sx} . u_d and u_q are the dq -axis components of u_x . e_d and e_q are the dq -axis components of e_x . i_d and i_q are the dq -axis components of i_x . i_{dg} and i_{qg} are the dq -axis components of i_{gx} ($x = a, b, c$). ω_1 is the grid voltage angular frequency.

Fig. 2 shows the equivalent circuit model of the grid-connected system in dq -frame based on (1)–(3). The control strategy of the controlled voltage sources u_{sd} and u_{sq} in Fig. 2 is shown in (4). Fig. 3 shows the control system of the grid-connected inverter

$$\begin{cases} u_{sd} = K_p (i_d^* - i_d) + K_i \int (i_d^* - i_d) dt - \omega_1 L_1 i_q + u_d \\ u_{sq} = K_p (i_q^* - i_q) + K_i \int (i_q^* - i_q) dt + \omega_1 L_1 i_d + u_q. \end{cases} \quad (4)$$

The grid-connected inverter adopts a single synchronous reference frame phase-locked loop (PLL) system based on the symmetrical component method [32]. The system decomposes the grid voltage into positive and negative sequences, and uses the positive sequence component as the input signal of the PLL.

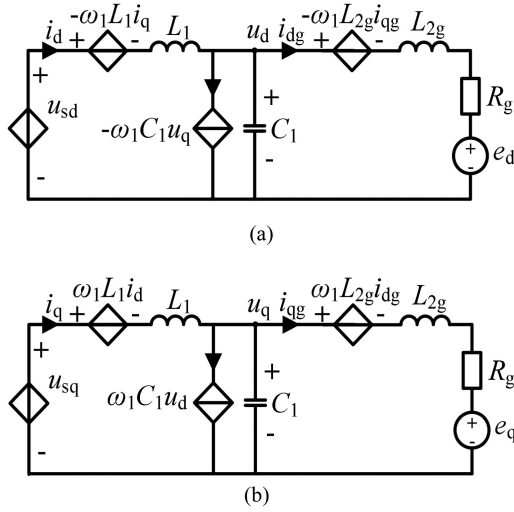

Fig. 2. Equivalent circuit model of the grid-connected system in dq -frame. (a) d -axis equivalent circuit model. (b) q -axis equivalent circuit model.

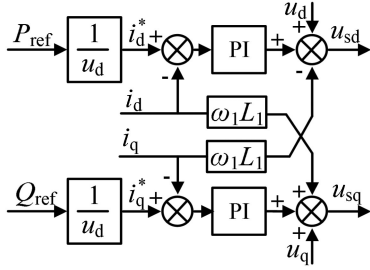

Fig. 3. Output voltage control schematic of the grid-connected inverter.

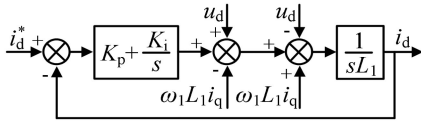

Fig. 4. Control block of i_d .

The input signal of the PLL is not affected by the oscillation, and the obtained PLL angle remains unchanged. Therefore, there the dynamic characteristic of the PLL is not considered in this article. Moreover, ignoring the delays of sampling devices and switching devices, substitution of (4) into (2) gives

$$\begin{cases} K_p (i_d^* - i_d) + K_i \int (i_d^* - i_d) dt - \omega_1 L_1 i_q + u_d \\ = -\omega_1 L_1 i_q + L_1 \frac{di_d}{dt} + u_d \\ K_p (i_q^* - i_q) + K_i \int (i_q^* - i_q) dt + \omega_1 L_1 i_d + u_q \\ = \omega_1 L_1 i_d + L_1 \frac{di_q}{dt} + u_q. \end{cases} \quad (5)$$

From (5), the control block of i_d is presented in Fig. 4, and the control block of i_q is the same as i_d .

According to Fig. 4, the transfer function of the current control loop is derived as

$$W_{ci}(s) = \frac{i_d(s)}{i_d^*(s)} = \frac{i_q(s)}{i_q^*(s)} = \frac{sK_p + K_i}{s^2 L_1 + K_p s + K_i}. \quad (6)$$

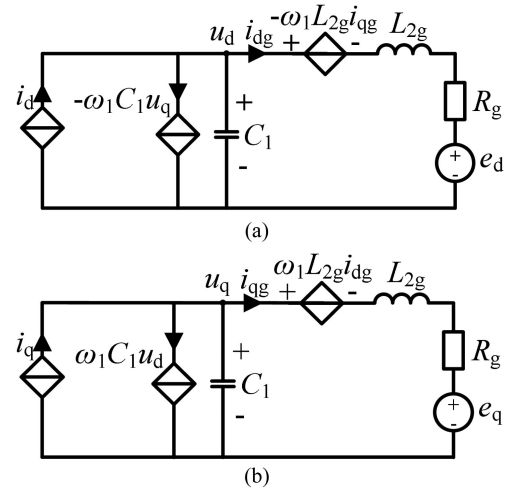

Fig. 5. Equivalent model of overvoltage analysis of the grid-connected system in dq -frame. (a) d -axis equivalent circuit model. (b) q -axis equivalent circuit model.

Furthermore, it is derived from (6) that

$$i_d(s) = \frac{sK_p + K_i}{s^2 L_1 + K_p s + K_i} i_d^*(s). \quad (7)$$

Then, the grid-connected inverter can be equivalent to a controlled current source. The output current of the grid-connected inverter is i_d , whose control coefficient is $W_{ci}(s)$. When the reference power generation P_{ref} of the grid-connected PV system steps, it will lead to a sudden jump of the reference current i_d^* , as shown in Fig. 3. From (7), reference current i_d^* will then affect the controlled current source i_d , which will result in interactions of the controller, filter, grid impedance, and grid. Fig. 5 presents the equivalent circuit models of the grid-connected system in dq -frame.

In this article, the grid-connected inverters are considered using the vector positioning control of the inverter terminal voltage, and operate in the unit power factor mode. i_q and u_q are both equal to zero. In the transient process of sudden changes of the inverter output power, the inverter still works in the unit power factor mode, i_q and u_q are still equal to zero. Therefore, the effect of the q -axis equivalent circuit model can be ignored in the analysis. The d -axis equivalent circuit model can be directly used to characterize the transient process of the grid-connected system caused by the sudden changes of the inverter output power.

III. THEORY OF GRID INDUCTANCE DETECTION

Fig. 6 shows the operational circuit of the equivalent model in Fig. 5(a). Fig. 6 illustrates that the inverter terminal voltage response caused by the sudden changes of the inverter output power is composed of the response of grid voltage e_d , the zero state response caused by the controlled current source i_d , and zero input responses caused by the initial value of the state quantity $u_q(0_-)$, $u_d(0_-)$, $i_{qg}(0_-)$, and $i_{dg}(0_-)$. Considering that grid-connected inverter normally operates in the unit power factor mode, $u_q(0_-)$ and $i_{qg}(0_-)$ are both equal to zero. Therefore,

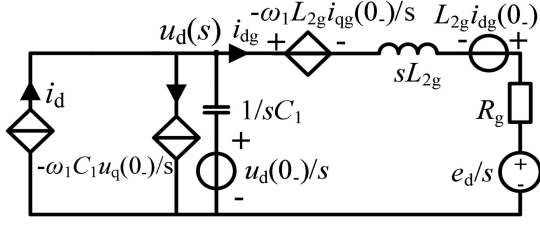

Fig. 6. Operational circuit of equivalent model for the grid-connected system terminal voltage analysis.

only e_d , i_d , $u_d(0_-)$, and $i_{dg}(0_-)$ work in the operational circuit of the equivalent model in Fig. 6. The time-domain expression of the controlled current source i_d in Fig. 6 can be expressed by

$$i_d(t) = i_d^* + A_1 e^{\alpha_1 t} + A_2 e^{\alpha_2 t}. \quad (8)$$

When i_d , $u_d(0_-)$, e_d , and $i_{dg}(0_-)$ act, respectively, the responses of the inverter terminal voltage $u_{d1}(t)$, $u_{d2}(t)$, $u_{d3}(t)$, and $u_{d4}(t)$ are derived as

$$u_{d1}(t) = B_1 e^{\beta t} \cos(\omega t) + B_2 e^{\beta t} \sin(\omega t) + B_3 e^{\alpha_1 t} + B_4 e^{\alpha_2 t} + i_d^* R_g \quad (9)$$

$$u_{d2}(t) = u_d(0_-) e^{\beta t} \cos(\omega t) + \frac{R_g u_d(0_-)}{2L_{2g} \sqrt{\frac{1}{L_{2g} C_1} - \frac{R_g^2}{4L_{2g}^2}}} e^{\beta t} \sin(\omega t) \quad (10)$$

$$u_{d3}(t) = e_d - e_d e^{\beta t} \cos(\omega t) - \frac{R_g e_d}{2L_{2g} \sqrt{\frac{1}{L_{2g} C_1} - \frac{R_g^2}{4L_{2g}^2}}} e^{\beta t} \sin(\omega t) \quad (11)$$

$$u_{d4}(t) = -\frac{i_{dg}(0_-)}{C_1 \sqrt{\frac{1}{L_{2g} C_1} - \frac{R_g^2}{4L_{2g}^2}}} e^{\beta t} \sin(\omega t). \quad (12)$$

Based on the superposition rule, the full response of the inverter terminal voltage can be further derived as

$$u_d(t) = u_{d1}(t) + u_{d2}(t) + u_{d3}(t) + u_{d4}(t) = D_1 e^{\beta t} \cos(\omega t) + D_2 e^{\beta t} \sin(\omega t) + D_3 e^{\alpha_1 t} + D_4 e^{\alpha_2 t} + e_d + i_d^* R_g \quad (13)$$

where α_1 , α_2 , and β are the attenuation coefficients of the transient components, and ω is the oscillation angular frequency of the inverter terminal voltage. The expressions are as follows:

$$\alpha_1 = \frac{-\frac{K_p}{L_1} + \sqrt{\frac{K_p^2}{L_1^2} - \frac{4K_i}{L_1}}}{2} \quad (14)$$

$$\alpha_2 = \frac{-\frac{K_p}{L_1} - \sqrt{\frac{K_p^2}{L_1^2} - \frac{4K_i}{L_1}}}{2} \quad (15)$$

$$\beta = -\frac{R_g}{2L_{2g}} \quad (16)$$

$$\omega = \sqrt{\frac{1}{L_{2g} C_1} - \left(\frac{R_g}{2L_{2g}}\right)^2}. \quad (17)$$

From (13), the inverter terminal voltage amplitude is determined by the controller parameters, filter parameters, grid impedance, the initial value of the state quantity, and the change value of the state quantity. From (14) to (16), the inverter terminal voltage attenuation time is determined by the controller parameters, filter inductance L_1 , grid inductance L_g , and grid resistance R_g . From (17), the inverter terminal voltage oscillation frequency is determined by the filter capacitance C_1 , grid inductance L_g , and grid resistance R_g .

According to the characteristic of the inverter terminal voltage oscillation frequency which is related to grid impedance during sudden change of the inverter output power, the grid inductance parameters can be obtained. In practical grid-connected PV systems, the grid inductance and filter inductance are in mH. The grid resistance is in m Ω . The filter capacitance is in μ F. In (17), $(R_g/2L_{2g})^2$ is far less than $(1/L_{2g}/C_1)$, which can be ignored. Therefore, we can simplify the frequency expression (17) as follows:

$$L_g = \frac{1}{\omega^2 C_f} - L_2. \quad (18)$$

This method uses the inherent oscillation characteristic of the inverter terminal voltage during sudden changes of the output power of a grid-connected system. The grid inductance can be obtained through the oscillation frequency. This method does not need to add additional signal generating devices and create new excitation signals. It also does not need complicated signal processing and calculation procedures. It should be mentioned that the proposed method and theoretical analysis are based on such terminal voltage oscillation phenomenon caused by the ‘‘sudden change’’ which is a fast and large power step-change artificially created in testing only. If the power change is not a ‘‘sudden change,’’ there would be no such obvious oscillation of the terminal voltage. Therefore, the proposed method would not affect normal operation, power quality, and other equipment at the PCC.

IV. SIMULATION VERIFICATION

The 10-kW grid-connected PV system in Fig. 1 is built in PSCAD/EMTDC with the system parameters shown in Table I. The simulation analyzed the electromagnetic transient process of a grid-connected PV system under sudden changes of the output power of the grid-connected inverter. The effectiveness that the oscillation mechanism of the inverter terminal voltage caused by the sudden changes of the grid-connected inverter output power, and the theory of the grid inductance detection proposed in this article are both verified. In the simulation, in order to obtain the responses of sudden changes of the grid-connected inverter output power, the grid-connected inverter is set to work in the non-MPPT state, and the grid-connected inverter reference generation power P_{ref} is changed through the controller. After

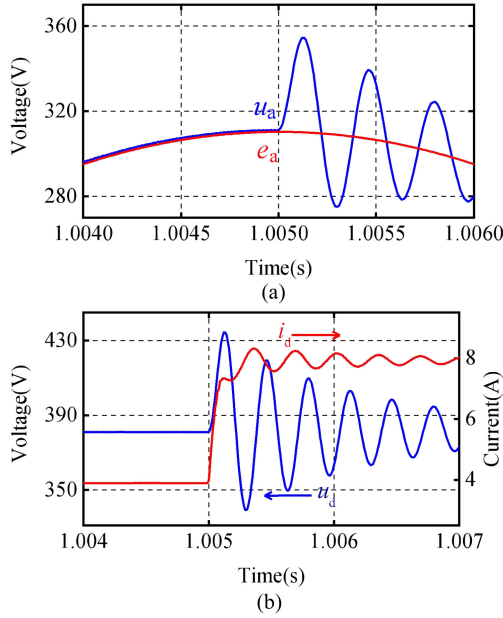

Fig. 7. Simulation waveforms of the grid-connected inverter when the sudden change of the grid-connected inverter output power. (a) Inverter terminal voltage (u_a) and grid voltage (e_a). (b) Inverter terminal voltage (u_d) and inverter output current (i_d).

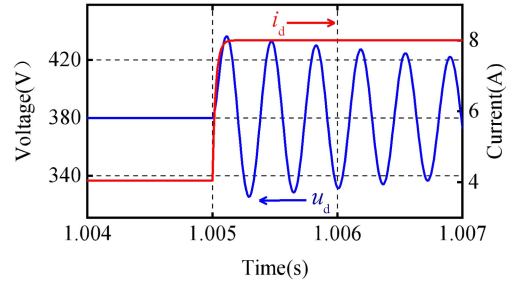

Fig. 9. Calculation waveforms of i_d and u_d .

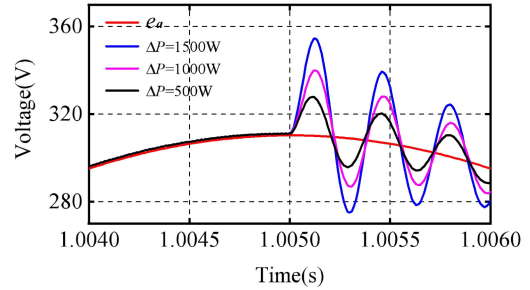

Fig. 10. Simulation waveforms of the inverter terminal voltage (u_a) and grid voltage (e_a) under different sudden changes of the grid-connected inverter output power.

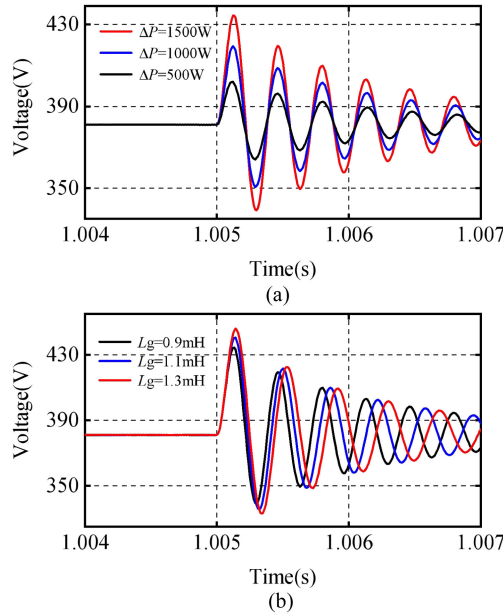

Fig. 8. Responses of the sudden inverter terminal voltage (u_d in dq -frame) when system parameters changes (a) under different sudden changes of the grid-connected inverter output power and (b) change of the grid inductance.

obtaining the inductance, the grid-connected inverter would be reset to the MPPT state.

The power sudden change is intentionally set at the peak of u_a ($t_0 = 1.005$ s). It is because that when the terminal voltage is at the peak moment, the initial value of the terminal voltage will be comparatively large, and therefore, the terminal voltage oscillation amplitude will be easier to be observed and recorded.

Fig. 11. Simulation waveforms of the inverter terminal voltage (u_a) and grid voltage (e_a) when grid inductance changes.

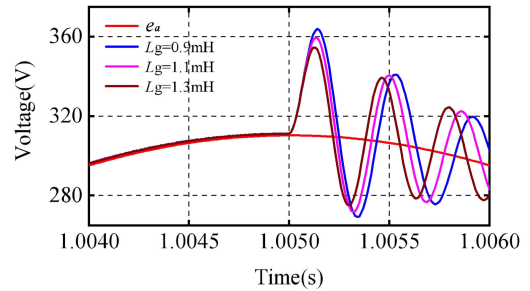

Fig. 7 presents the simulation waveforms of the inverter terminal voltage, the grid voltage, and the inverter output current when the grid-connected inverter reference generation power P_{ref} was changed from 1.5 to 3.0 kW.

Fig. 7(b) illustrates that grid-connected inverter output power steps, and i_d rises instantaneously, which further causes the inverter terminal voltage oscillation. Sudden changes of the inverter output power and the grid inductance are conducted to further verify the effectiveness of the proposed analysis of the inverter terminal voltage oscillations.

Fig. 8(a) illustrates that the inverter terminal voltage oscillation amplitude changes under different sudden changes of the grid-connected inverter output power. However, it should be noted that oscillation frequency of the inverter terminal voltage remains unchanged. Fig. 8(b) shows that the oscillation amplitude and frequency of the inverter terminal voltage both change when grid inductance changes. It can be concluded that

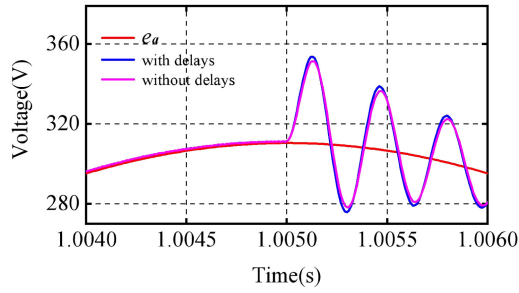

Fig. 12. Simulation waveforms of the inverter terminal voltage (u_a) and grid voltage (e_a) considering and without considering the delays.

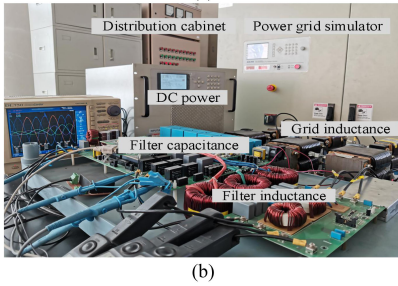
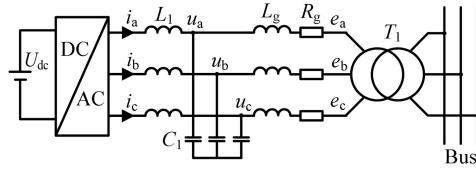

Fig. 13. Experimental setup. (a) Circuit diagram. (b) Photograph.

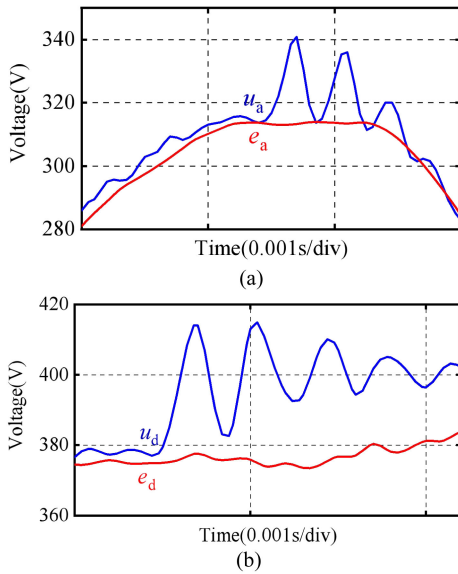

Fig. 14. Experimental waveforms of the inverter voltages and grid voltage when the inverter output power changed. (a) Inverter terminal voltage (u_a) and grid voltage (e_a). (b) Inverter terminal voltage (u_d) and grid voltage (e_d).

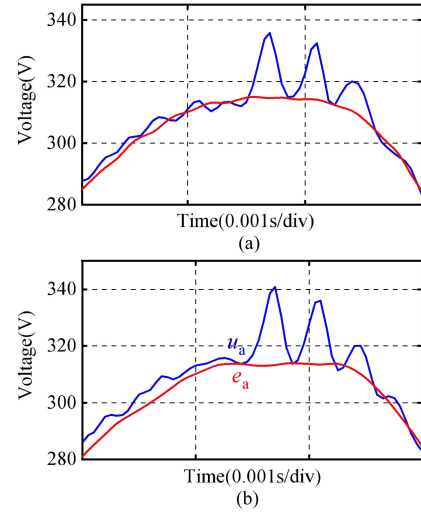

Fig. 15. Experimental waveforms of the inverter terminal voltage (u_a) and grid voltage (e_a) under different sudden changes of the grid-connected inverter output power changes. (a) $\Delta P = 1000$ W. (b) $\Delta P = 1500$ W.

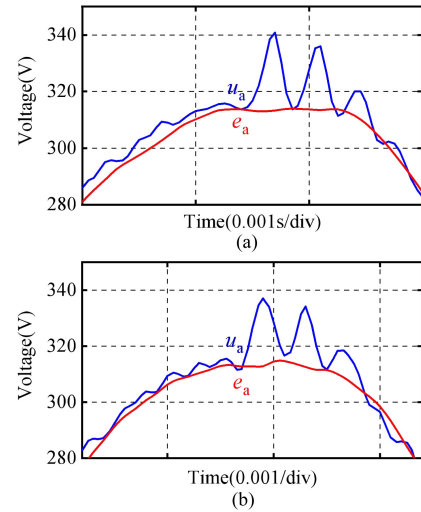

Fig. 16. Experimental waveforms of the inverter terminal voltage (u_a) and grid voltage (e_a) when grid inductance changes. (a) $L_g = 2.2$ mH. (b) $L_g = 3.5$ mH.

TABLE I
PARAMETERS FOR THE PV SIMULATION SYSTEM

Parameters	Symbols	Values
Filter capacitance	C_1	3.3 μF
Filter inductance	L_1	5.0 mH
Common mode inductance	L_2	0.1 mH
Grid inductance	L_g	0.9 mH
Grid resistance	R_g	200 m Ω
Voltage angular frequency	ω_1	314 rad/s
Grid voltage	e_x	220 V
Proportion coefficient	K_p	200
Integral coefficient	K_i	10000
PWM frequency	f_{PWM}	20 kHz

TABLE II
SIMULATION RESULTS OF DIFFERENT POWER VARIATIONS

Power Variations (W)	Inductance (mH)	Accuracy (%)
500	0.846	94.0
1000	0.839	93.2
1500	0.842	93.5

the frequency of the inverter terminal voltage is only related to the grid inductance, and is not related to the sudden changes of the grid-connected inverter output power, which is consistent with the above theoretical analysis.

The effectiveness of the theory of grid inductance detection based on oscillation characteristic of the inverter terminal voltage is further verified. From the system parameters in Table I, the currents and voltages [in (8) and (13)] before and after the output power sudden change are changed into

$$i_d(t) = 8.00 - 3.95e^{-39550(t-t_0)} + 0.0049e^{-50.06(t-t_0)} \quad (19)$$

$$\begin{aligned} u_d(t) = & 380.00 - 25.17e^{-100.00(t-t_0)} \cos(17407.48t) \\ & + 51.38e^{-100.00(t-t_0)} \sin(17407.48t) \\ & + 25.17e^{-39550.00(t-t_0)} + 0.00074e^{-50.06(t-t_0)}. \end{aligned} \quad (20)$$

Fig. 9 shows the waveforms of (19) and (20). From the simulation results in Fig. 7(a), the measured inverter terminal voltage oscillation frequency is 2849.34 Hz. From (17), the theoretical calculation inverter terminal voltage oscillation frequency in Fig. 9 is 2771.89 Hz, which is 77.45 Hz different from the simulation result, and the theoretical calculation error is 2.79%. The grid inductance L_g calculation result is 0.846 mH through the oscillation frequency, and the detection accuracy is 94.0%. In this article, the oscillation frequency characteristic of the inverter terminal voltage is investigated, and the oscillation attenuation characteristic of the inverter terminal voltage is not accurately considered. But the attenuation characteristic of the inverter terminal voltage does not affect measurement results of the inverter terminal voltage oscillation frequency. Therefore, the attenuation time in Fig. 9 can be ignored.

The sudden changes of the grid-connected inverter output power and the grid inductance are conducted to further verify the effectiveness of the proposed method of grid inductance detection. In the simulation, the grid inductance L_g is 0.9 mH. Fig. 10 presents the simulation waveforms of the inverter terminal voltage and grid voltage under different sudden changes of the grid-connected inverter output power. The grid inductance detection values and detection accuracy are shown in Table II.

From the simulation results in Fig. 10, the oscillation amplitudes of the inverter terminal voltage changes under different sudden changes of the grid-connected inverter output power. However, the oscillation frequency of the inverter terminal voltage remains unchanged. Detection results in Table II show that the grid inductance detection accuracy maintains within the range of 90%–95%.

TABLE III
SIMULATION RESULTS OF DIFFERENT LINE INDUCTANCE

Actual Value (mH)	Detection Value (mH)	Accuracy (%)
0.9	0.842	93.5
1.1	1.036	94.2
1.3	1.217	93.6

TABLE IV
SETUP OF THE PV EXPERIMENTAL SYSTEM

Parameters	Symbols	Values
Filter capacitance	C_1	3.3 μ F
Filter inductance	L_1	2.1 mH
Grid inductance	L_g	2.2 mH
Grid resistance	R_g	63 m Ω
Voltage angular frequency	ω_1	314 rad/s
Grid voltage	e_s	220 V
Proportion coefficient	K_p	30
Integral coefficient	K_i	0.1
DC bus voltage	U_{dc}	680 V
PWM frequency	f_{PWM}	16 kHz

In the simulation, the sudden change of the grid-connected inverter output power $\Delta P = 1500$ W. Fig. 11 presents the simulation waveforms of the inverter terminal voltage when the grid inductance is changed. The grid inductance detection values and accuracy are shown in Table III.

Based on the simulation results in Fig. 11, the oscillation amplitude and frequency of the inverter terminal voltage both change when grid inductance changes. Detection results in Table III show that grid inductance detection accuracy maintains within the range of 90%–95%.

To investigate if the sampling and PWM modulation delays (0.075 ms) will affect the oscillation amplitude and frequency of the inverter terminal voltage, we have conducted simulations considering the delays. Fig. 12 shows the simulation waveform of the inverter terminal voltage considering and without considering the delays. It can be concluded that the delays slightly affect the voltage amplitude but do not affect the oscillation frequency of the inverter.

The simulation results show the effectiveness of the proposed theory of grid inductance detection based on the oscillation characteristic of the inverter terminal voltage.

V. EXPERIMENTAL VALIDATION

Experiments have been conducted to further validate the effectiveness of the proposed method. Fig. 13(a) illustrates the circuit diagram, and Fig. 13(b) shows the photograph of the 10 kW experimental setup of a practical grid-connected PV system. The setup is described in Table IV.

At the instant of phase A's peak voltage, the grid-connected inverter reference generation power P_{ref} was changed from 1000 to 2500 W ($\Delta P = 1500$ W, 15% of the rated capacity). Fig. 14 presents the experimental waveforms of the inverter terminal voltage and grid voltage.

TABLE V
EXPERIMENTAL RESULTS OF DIFFERENT POWER VARIATIONS

Power Variation (W)	Inductance (mH)	Accuracy (%)
1000	1.90	86.4
1500	1.92	87.3

TABLE VI
EXPERIMENTAL RESULTS OF DIFFERENT LINE INDUCTANCE

Actual Value (mH)	Detection Value (mH)	Accuracy (%)
2.2	1.92	87.3
3.5	3.00	85.7

Fig. 14 illustrates that when the grid-connected inverter reference generation power P_{ref} steps, i_d rises instantaneously, causing the inverter terminal voltage to oscillate. Substituting the relevant parameters of the experimental system in Table IV into (13), the expression of u_d can be obtained as follows:

$$u_d(t) = 380 - 34.727e^{-14.31t} \cos(11736.31t) + 18.95e^{-14.31t} \sin(11736.31t) - 4.255 * 10^{-6}e^{-0.08t} + 34.72e^{-4652t}. \quad (21)$$

Fig. 14(a) shows the measured inverter terminal voltage oscillation frequency is 2000.47 Hz. From (17), the theoretical calculation oscillation frequency of the inverter terminal voltage is 1868.84 Hz, which shows a relative error of 7.04% compared with the experimental results. The calculation result of the grid inductance L_g is 1.92 mH. Based on the results, the accuracy of the proposed method is 87.3%.

The sudden changes of the grid-connected inverter output power and the grid inductance are conducted to further validate the effectiveness of the proposed method of grid inductance detection. In the experiment, grid inductance L_g is 2.2 mH. Fig. 15 presents the experimental waveforms of the inverter terminal voltage and grid voltage under different sudden changes of the grid-connected inverter output power. The value and accuracy of the grid inductance detection are shown in Table V.

In the experiment, the sudden change of the grid-connected inverter output power $\Delta P = 1500$ W. Fig. 16 presents the experimental waveforms of the inverter terminal voltage and grid voltage when the grid inductance is changed. The grid inductance detection value and accuracy are shown in Table VI.

Detection results in Tables V and VI show that the grid inductance detection accuracy maintains within the range of 85%–87%. The experimental results validate the effectiveness of the method of the grid inductance online detection based on the oscillation characteristic of inverter terminal voltage.

VI. CONCLUSION

In this article, an LC-type grid-connected PV system was investigated. An equivalent circuit model of a grid-connected PV system including a controller was established. The oscillation characteristic of the inverter terminal voltage caused by the sudden change of the inverter output power was analyzed. An online detection method of grid inductance based on the oscillation

characteristic of the inverter terminal voltage was proposed. The contribution of this method is that it does not need complicated signal processing and calculation procedures. Instead, it only uses the measurement of the oscillation frequency of the inverter terminal voltage. Simulation and experimental results validated the correctness and effectiveness of the proposed method. It will provide a new theoretical basis for grid inductance detection.

REFERENCES

- [1] T. Strasser, F. Andren, and J. Kathan, "A review of architectures and concepts for intelligence in future electric energy systems," *IEEE Trans. Ind. Electron.*, vol. 62, no. 4, pp. 2424–2438, Apr. 2015.
- [2] S. K. Tiwari, B. Singh, and P. K. Goel, "Design and control of microgrid fed by renewable energy generating sources," *IEEE Trans. Ind. Appl.*, vol. 54, no. 3, pp. 2041–2050, May 2018.
- [3] X. Liang, "Emerging power quality challenges due to integration of renewable energy sources," *IEEE Trans. Ind. Appl.*, vol. 53, no. 2, pp. 855–866, Mar. 2017.
- [4] M. Ben Saïd-Romdhane, M. W. Naouar, I. Slama-Belkhdja, and E. Monmasson, "Robust active damping methods for LCL filter-based grid-connected converters," *IEEE Trans. Power Electron.*, vol. 32, no. 9, pp. 6739–6750, Sep. 2017.
- [5] M. Sumner, A. Abusorrah, D. Thomas, and P. Zanchetta, "Real time parameter estimation for power quality control and intelligent protection of grid-connected power electronic converters," *IEEE Trans. Smart Grid*, vol. 5, no. 4, pp. 1602–1607, Jul. 2014.
- [6] J. Fang, P. Lin, H. Li, and Y. Tang, "A improved virtual inertia control for three-phase voltage source converters connected to a weak grid," *IEEE Trans. Power Electron.*, vol. 34, no. 9, pp. 8660–8670, Sep. 2019.
- [7] J. De Kooning, J. van de Vyver, J. D. M. De Kooning, T. L. Vandoorn, and L. Vandevelde, "Grid voltage control with distributed generation using online grid impedance," *Sustain. Energy, Grids Netw.*, vol. 5, pp. 70–77, 2016.
- [8] A. Vijayakumanri, A. T. Devarajan, and N. Devarajan, "Decoupled control of grid connected inverter with dynamic online grid impedance measurements for micro grid applications," *Int. J. Elect. Power Energy Syst.*, vol. 68, pp. 1–14, 2015.
- [9] A. Ghanem, M. Rashed, M. Sumner, M. A. Elsayes, and I. I. I. Mansy, "Grid impedance estimation for islanding detection and adaptive control of converters," *IET Power Electron.*, vol. 10, no. 11, pp. 1279–1288, Sep. 2017.
- [10] M. Cespedes and J. Sun, "Adaptive control of grid-connected inverters based on online grid impedance measurements," *IEEE Trans. Sustain. Energy*, vol. 5, no. 2, pp. 516–523, Apr. 2014.
- [11] N. Mohammed, T. Kerekes, and M. Ciobotaru, "An online event-based grid impedance estimation technique using grid-connected inverters," *IEEE Trans. Power Electron.*, vol. 36, no. 5, pp. 6106–6117, May 2021.
- [12] L. Asiminoaei, R. Teodorescu, F. Blaabjerg, and U. Borup, "Implementation and test of an online embedded grid impedance estimation technique for PV inverters," *IEEE Trans. Ind. Electron.*, vol. 52, no. 4, pp. 1136–1144, Aug. 2005.
- [13] V. Timbus, A. R. Teodorescu, F. Blaabjerg, and U. Borup, "Online grid measurement and ENS detection for PV inverter running on highly inductive grid," *IEEE Power Electron. Lett.*, vol. 2, no. 3, pp. 77–82, Sep. 2004.
- [14] M. Ciobotaru, R. Teodorescu, and F. Blaabjerg, "Online grid impedance estimation based on harmonic injection for grid-connected PV inverter," in *Proc. IEEE Int. Symp. Ind. Electron.*, Jun. 2007, pp. 2437–2442.
- [15] P. García, M. Sumner, A. Navarro-Rodríguez, J. M. Guerrero, and J. García, "Observer-based pulsed signal injection for grid impedance estimation in three-phase systems," *IEEE Trans. Ind. Electron.*, vol. 65, no. 10, pp. 7888–7899, Oct. 2018.
- [16] T. Roinila, T. Messo, T. Suntio, and M. Vilkkö, "Pseudo-random sequences in DQ-domain analysis of feedforward control in grid-connected inverters," *IFAC-Papers OnLine*, vol. 48, no. 28, pp. 1301–1306, 2015.
- [17] A. Riccobono *et al.*, "Online wideband identification of three-phase AC power grid impedances using an existing grid-tied power electronic inverter," in *Proc. IEEE 17th Workshop Control Model. Power Electron.*, Jun. 2016, pp. 1–8.
- [18] S. Neshvad, S. Chatzinotas, and J. Sachau, "Wideband identification of power network parameters using pseudo-random binary sequences on power inverters," *IEEE Trans. Smart Grid*, vol. 6, no. 5, pp. 2293–2301, Sep. 2015.

- [19] A. V. Timbus, R. Teodorescu, and P. Rodriguez, "Grid impedance identification based on active power variation and grid voltage control," in *Proc. IEEE Ind. Appl. Annu. Meeting*, Sep. 2007, pp. 949–954.
- [20] L. Wang, J. Chen, X. Li, X. Sun, and J. M. Guerrero, "Fundamental impedance identification method for grid-connected voltage source inverters," *IET Power Electron.*, vol. 7, no. 5, pp. 1099–1105, 2014.
- [21] J. H. Cho, K. Y. Choi, Y. W. Kim, and R. Y. Kim, "A novel P-Q variations method using a decoupled injection of reference currents for a precise estimation of grid impedance," in *Proc. IEEE Energy Convers. Congr. Expo.*, Nov. 2014, pp. 5059–5064.
- [22] N. Mohammed, M. Ciobotaru, and G. Town, "An improved grid impedance estimation technique under unbalanced voltage conditions," in *Proc. IEEE PES Innov. Smart Grid Technol. Eur.*, 2019, pp. 1–5.
- [23] J. Fang, H. Deng, and S. M. Goetz, "Grid impedance estimation through grid-forming power converters," *IEEE Trans. Power Electron.*, vol. 36, no. 2, pp. 2094–2104, Feb. 2021.
- [24] M. A. Azzouz and E. F. El-Saadany, "Multivariable grid admittance identification for impedance stabilization of active distribution networks," *IEEE Trans. Smart Grid*, vol. 8, no. 3, pp. 1116–1128, May 2017.
- [25] D. K. Alves, R. L. d. A. Ribeiro, F. B. Costa, T. d. O. A. Rocha, and J. M. Guerrero, "Wavelet-based monitor for grid impedance estimation of three-phase networks," *IEEE Trans. Ind. Electron.*, vol. 68, no. 3, pp. 2564–2574, Mar. 2021.
- [26] S. Cobrecas, E. J. Bueno, D. Pizarro, F. J. Rodriguez, and F. Huerta, "Grid impedance monitoring system for distributed power generation electronic interfaces," *IEEE Trans. Instrum. Meas.*, vol. 58, no. 9, pp. 3112–3121, Sep. 2009.
- [27] M. Liserre, F. Blaabjerg, and R. Teodorescu, "Grid impedance estimation via excitation of LCL-filter resonance," *IEEE Trans. Ind. Appl.*, vol. 43, no. 5, pp. 1401–1407, Sep. 2007.
- [28] N. Hoffmann and F. W. Fuchs, "Minimal invasive equivalent grid impedance estimation in inductive-resistive power networks using extended kalman filter," *IEEE Trans. Power Electron.*, vol. 29, no. 2, pp. 631–641, Feb. 2014.
- [29] G. Welch and G. Bishop, "An introduction to the kalman filter," Univ. North Carolina, Chapel Hill, NC, USA, Tech. Rep. TR 95-041, 2004.
- [30] V. Valdivia, A. Lázaro, A. Barrado, P. Zumel, C. Fernández, and M. Sanz, "Impedance identification procedure of three-phase balanced voltage source inverters based on transient response measurements," *IEEE Trans. Power Electron.*, vol. 26, no. 12, pp. 3810–3816, Dec. 2011.
- [31] A. Vidal *et al.*, "A method for identification of the equivalent inductance and resistance in the plant model of current-controlled grid-tied converters," *IEEE Trans. Power Electron.*, vol. 30, no. 12, pp. 7245–7261, Dec. 2015.
- [32] S.-J. Lee, J.-K. Kang, and S.-K. Sul, "A new phase detecting method for power conversion systems considering distorted conditions in power system," in *Proc. IEEE Ind. Appl. Conf., 34 IAS Annu. Meeting*, 1999, pp. 2167–2172.



Shuangming Duan (Member, IEEE) received the B.Eng. degree in electronic information science and technology from Northeast Electric Power University, Jilin, China, in 2007, and the M.Sc. and Ph.D. degrees in electrical engineering from Northeast Electric Power University, Jilin, China, in 2013 and 2018, respectively.

He is currently an Experimenter with the Department of Electrical Engineering, Northeast Electric Power University. His research interests include control of distributed generation in more-electronics

power systems and application of large-scale energy storage technology.



Bo Xia received the B.Eng. degree in electrical engineering in 2019 from Northeast Electric Power University, Jilin, China, where he is currently working toward the M.Sc. degree.

His research interests include control of photovoltaic grid-connected inverter.



Gangui Yan (Member, IEEE) received the B.Eng. and M.Sc. degrees from Northeast Electric Power University, Jilin, China, in 1994 and 1997, respectively, and the Ph.D. degree from Tsinghua University, Beijing, China, in 2003, all in electrical engineering.

He is currently a Professor with the Department of Electrical Engineering, Northeast Electric Power University. His research interests include large-scale integration of wind power into power systems, photovoltaic generation control, and VSC-based

HVdc control.

Prof. Yan is a Vice Chairman of IEEE PES Renewable Systems Integration Satellite Committee—China. He is a senior member of CSEE. He is a secretary of Electrical Engineering Mathematic Council of CSEE. He is selected into the National Hundreds and Thousands of Talents Project. He is a Young and Middle-Aged Expert with outstanding contributions from the state. He is an expert enjoying the Special Government Allowance. He is selected as a special professor of "Changjiang Scholars" of the Ministry of Education. He was the recipient of two Prizes of "Science and Technology Progress" of Nation.



Nan Li received the B.Eng. and M.Sc. degrees in electrical engineering from Northeast Electric Power University, Jilin, China, in 2016 and 2019, respectively.

She is currently an Engineer with the State Grid Liaoning Extra High Voltage Company, Shenyang, China. Her research interests include stability analysis of photovoltaic grid-connected inverter.



Gen Li (Member, IEEE) received the B.Eng. degree in electrical engineering from Northeast Electric Power University, Jilin, China, in 2011, the M.Sc. degree in power engineering from Nanyang Technological University, Singapore, in 2013, and the Ph.D. degree in electrical engineering from Cardiff University, Cardiff, U.K., in 2018.

From 2013 to 2016, he was a Marie Curie Early Stage Research Fellow funded by the European Commission's MEDOW project. He has been a Visiting Researcher with China Electric Power Research Institute and Global Energy Interconnection Research Institute, Beijing, China, with Elia, Brussels, Belgium, and with Toshiba International (Europe), London, U.K. He has been a Research Associate with the School of Engineering, Cardiff University, since 2017. His research interests include control and protection of HVdc and MVdc technologies, power electronics, reliability modeling, and evaluation of power electronics systems.

Dr. Li is a Chartered Engineer in the U.K. He is an Associate Editor for the *CSEE Journal of Power and Energy Systems*. He is an Editorial Board Member of CIGRE ELECTRA. He is an IET Professional Registration Advisor. His Ph.D. thesis received the First CIGRE Thesis Award in 2018. He is the Vice-Chair of IEEE PES Young Professionals and the Technical Panel Secretary of CIGRE U.K. B5 Protection and Automation.

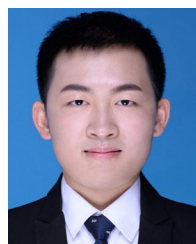

Yi Ding received the B.Eng. degree in transmission engineering in 2017 from Northeast Electric Power University, Jilin, China, where he is currently working toward the M.Sc. degree.

His research interests include operation control of microgrid.