

# Review and Classification of MTPA Control Algorithms for Synchronous Motors

Anton Dianov , *Senior Member, IEEE*, Fabio Tinazzi , *Member, IEEE*, Sandro Calligaro , *Member, IEEE*, and Silverio Bolognani , *Fellow, IEEE*

**Abstract**—This article discusses the maximum torque per ampere (MTPA) control of synchronous motors, which have become an indispensable part of highly efficient motor drives. It explains the nature of torque produced by synchronous motors, ways to find its maximum and algorithms to operate at this point, despite changes of loads and motor parameter variations. The authors propose a classification of the MTPA methods, based on the features of each algorithm or group of similar methods. They demonstrate the conventional control scheme and discuss the modifications necessary for the implementation of each method. This article reviews existing MTPA control algorithms, discusses their pros and cons, and suggests possible areas of usage for each group of methods. The authors of the article share their vast experience in the industry and research aspects, which were obtained by developing industrial, commercial, traction, and military drives, and report on their views on the perspective of each method taken into consideration.

**Index Terms**—Energy efficiency, permanent magnet (PM) motors, synchronous motors, torque control.

## I. INTRODUCTION

TRADITIONALLY, synchronous machines (SM) were not as popular as induction machines (IM) and they have mainly been used in specific areas, such as power generation, precision servodrives, and robots. Despite this fact, many researchers paid attention to these machines and proposed a number of different designs of SM, which differ by efficiency, cost reliability, etc., and have both their advantages and drawbacks. The most popular designs of SM are shown in Fig. 1, where rotors of four-poled machines are illustrated.

However, during the last two decades, the situation has changed rapidly and the area of usage of SM has continuously increased. It has mainly occurred because of the increase in popularity of permanent magnet synchronous motors (PMSMs), which have expanded and penetrated into various sectors, where

other types of motors dominated before. Previously, only low-power PMSM successfully competed against others (mainly dc and induction motors), however nowadays the range of their power is expanding. It mainly happened because of progress in magnet technology, decreasing in the price of rare-earth magnets and further development in power electronics and control techniques; as a result, permanent magnet (PM) motors are being utilized in traction drives of electrical vehicles (EV) and propulsion systems in the aviation and marine industry, etc.

At the same time, with the rise in popularity of PMSM, synchronous reluctance motors (SynRMs), together with PM-assisted synchronous reluctance motors (PMSynRMs), attract more scientists and a number of works dedicated to the design of motors of these types and their control are published [1]–[3]. SynRM can be considered as an alternative to the induction motors in the low and middle power range (tens of kilowatt) due to their higher efficiency, simplicity, and cheaper cost. Therefore, their main area of usage is similar to IM and includes heating ventilation, air conditioning (HVAC), pumps, conveyors, the textile and paper industry, etc. [4].

Switched reluctance motors (SRMs) are also a kind of SM; they still involve only reluctance components of torque, but they belong to the category of phase-commuted motors (as stepping motors, brushless, and brush dc motors), rather than that of rotating field motors. They are quite reliable and cheap, but they have the drawback of strong vibrations, which restricts the field of application essentially to traction [5]. SRMs are typically designed with independent phases and therefore they need specific electronic and control algorithms. Wang and Fahimi [6] considered such system and propose the corresponding maximum torque per ampere (MTPA) control. Simultaneously, some research works tried to involve conventional topology and control of SRM [7]. As a result, from the MTPA point of view, they are similar to SynRM and will not be considered separately.

Torque mechanism in SM can be explained, as in all motors, by the interaction between stator current distribution and air gap flux distribution (see [8]). In order to produce a not null resulting torque by the interaction forces, the two distributions must be, at least partially, in phase. A machine with an isotropic and passive rotor exhibits stator current and air gap flux distributions that are in quadrature, resulting in a null torque.

A PM (or a wound) excitation is used to intensify the in-phase component of the air gap flux distribution in isotropic rotor machines, allowing the so-called PM torque to be generated. PM excitation has, of course, identical pole number of stator

Manuscript received March 31, 2021; revised June 24, 2021 and September 8, 2021; accepted October 20, 2021. Date of publication October 27, 2021; date of current version December 31, 2021. Recommended for publication by Associate Editor H. Hofmann. (Corresponding author: Anton Dianov.)

Anton Dianov is with the This is Engineering Inc., Seongnam 13449, South Korea (e-mail: anton.dianov@samsung.com).

Fabio Tinazzi is with the Department of Engineering and Management, University of Padova, 36100 Vicenza, Italy (e-mail: fabio.tinazzi@unipd.it).

Sandro Calligaro is with the Faculty of Science and Technology, University of Bolzano, 39100 Bolzano, Italy (e-mail: sandro.calligaro@unibz.it).

Silverio Bolognani is with the Department of Industrial Engineering, University of Padova, 35122 Padua, Italy (e-mail: edlab@dii.unipd.it).

Color versions of one or more figures in this article are available at <https://doi.org/10.1109/TPEL.2021.3123062>.

Digital Object Identifier 10.1109/TPEL.2021.3123062

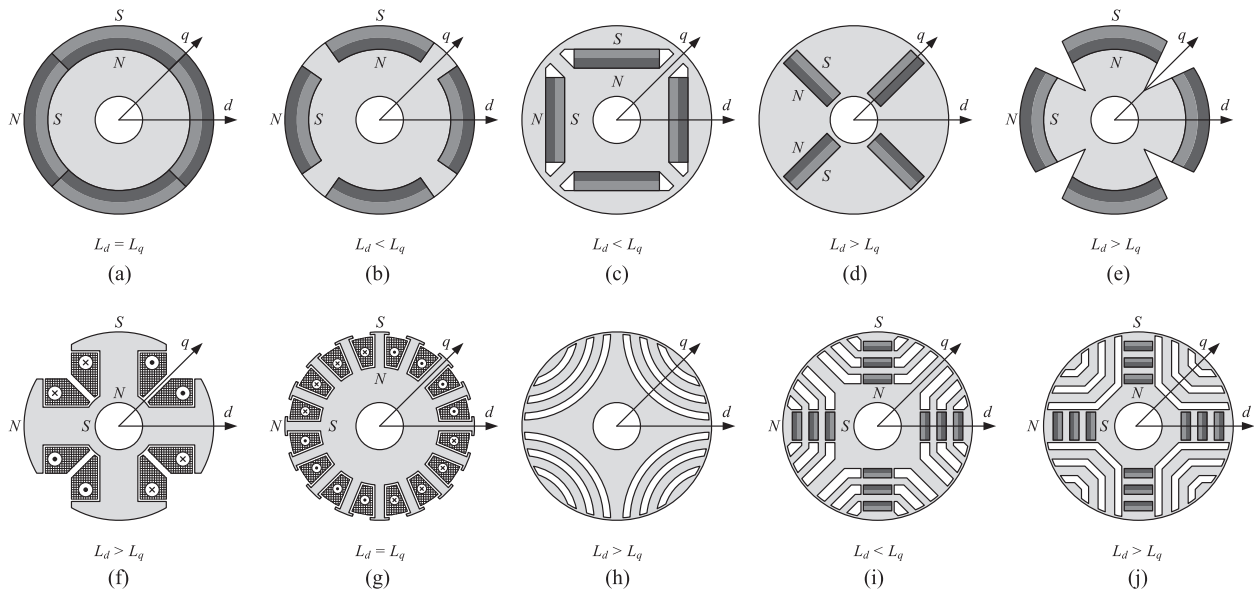

Fig. 1. Design of the most popular synchronous motors: (a) surface mounted magnets, (b) inset magnets, (c) interior tangential magnets, (d) interior radial magnets, (e) pole salient with magnets, (f) pole salient wound rotor, (g) nonpole salient wound rotor, (h) synchronous reluctance, (i) and (j) PM assisted synchronous reluctance.

winding and stator current distribution and PM excitation are synchronized during rotation.

The same scope is reached, however by a different approach, in a SynRM, which is designed to have a rotor magnetic asymmetry (different inductances), along direct and quadrature axes. The primary effect is magnifying the flux distribution component in phase with the current distribution, dropping at the same time as the quadrature one. By a current distribution maintained in an appropriate phase with respect to rotor axes, this rotor asymmetry allows a reluctance torque to be created.

Of course, the two mechanisms can be combined, as in interior PM (IPM) SM and in PMaSynRM. Even for motors with equal direct  $L_d$  and quadrature  $L_q$  inductances, the asymmetry may take place at load conditions, when rotor steel is saturated unevenly in these directions. The same steel saturation affects the appropriate phase of the stator current distribution in motor designed with intentional different axis inductances. Such behavior is difficult to be modeled and exploiting it for the best drive performance is challenging.

High-efficient control systems must consider these features and operate at the maximum point of resulting motor torque. The motor control techniques, which consider both PM and reluctance torque and provide maximum resulting torque, are called MTPA control.

Nowadays, a large chunk of the worldwide electric energy consumption is due to electric motors used in applications such as pumps, fans, and compressors (see [9]). The variable speed drives permit to increase their overall efficiency, but for most of the time, these applications run at steady-state operations. Therefore, the energy efficiency is of utmost importance, and the application of variable frequency drives should be able to provide it. Energy efficiency is rapidly becoming an imperative, also due to recent standards that may force the redesign of the electric machines [10]. In turn, the control technique plays a

crucial role in the energy efficient operations of the electric drive. This aspect is expected to increase in importance even more in the future. These techniques have become an indispensable part of control systems of SM, especially those that operate in EV, hybrid EV, and other autonomous objects, which focus on efficiency.

MTPA algorithms originally came from motor power loss minimization techniques, which were developed in order to maximize efficiency of the motor or system power converter-motor. There are many approaches to this minimization, which differ by the loss taken into account. They may consider only motor or system comprising motor and inverter; they may optimize only Joule loss or take power loss in steel into account as well, etc., which is clearly demonstrated in [11] and [12]. Unfortunately, the calculation of the total loss is a difficult and challenging task, which needs developing of proper models and complex computations, therefore these techniques have limited usage.

At the same time, the most significant power losses are the Joule losses [13], thus for the purpose of simplification, they are taken into account exclusively. Therefore, power losses can be approximately considered to be directly proportional to square of the magnitude of stator current. Thus, minimizing the copper losses corresponds to the implementation of a practical suboptimal solution. This idea results in different implementations of MTPA, which provide minimum current consumption for the given torque, however total power loss may not be minimized. Nevertheless, this approach is considered optimal, due to its simplicity and, therefore, MTPA is a more popular approach than power loss minimization.

The maximum power factor methods in synchronous motor drives can be profitably used for reducing the VA sizing of the converter, however at the price of oversizing the motor power rating. In fact, the reactive power can be delivered by PM electromotive force, which results in higher than terminal voltages. The

reactive power in SynRM drives must be delivered by external sources [14], i.e., the terminal supply, as there is no internal electromotive force. Therefore, the power factor is necessarily limited, and it can be partially improved by PMA SynRMs.

Keeping these aspects in mind, the authors can note that despite MTPA techniques mainly being used for pole salient synchronous motors, these considerations can be spread over other types of motors, which is perfectly demonstrated in [7], [6], and [15]–[20]. For this reason, Sung *et al.* [15] and Hesar *et al.* [16] discuss high-efficient control of induction motor for vehicle application. The article [17] is dedicated instead to the operation at maximum thrust per ampere curve of linear induction motor, whereas article [18] considers MTPA operation of induction motor taking iron loss into account. In [6] and [7], MTPA control for SRMs is proposed and papers [19] and [20] develop MTPA control for doubly fed induction motors and SynRM, respectively.

The conventional approach to this problem is the calculation of MTPA equations obtained from the motor model by differentiating the motor torque equation with respect to the stator current. These MTPA equations are analytical solutions for this problem, which are frequently obtained under the assumption that motor parameters are stable and do not depend on other variables [21], [22]. However, motor parameters vary depending on the operating conditions and the most significant changes are in inductances, because of the steel saturation; cross-saturation, and flux linkage, which is affected by temperature. These variations depend on the motor designs, and may exceed 70% for inductances in SynRM [23], [24] and up to 10%–20% for flux-linkages in PM motors operating at high temperatures [25]–[27], e.g., motors in the oil industry. Therefore, these changes must be taken into account. Furthermore, in case of demagnetization, the decrease of flux-linkage may reach 50%, which must be considered in fault-tolerant drives.

In order to adjust the control algorithm to motor parameters variation, many researchers proposed online monitoring of motor parameters and using them in the conventional MTPA equations. These approaches differ in parameter estimation techniques and number of parameters under control. They include inductance estimators [28], [29] and flux linkage monitoring [30], [31], however, all of them consider only slow parameters variation with negligible time derivatives, which makes dynamic performance poorer.

In addition, these methods need prior knowledge of motor parameters, which is inconvenient for general purpose industrial drives intended to operate with different motors. For this reason, special techniques, which do not use motor parameters, have been proposed. They track the MTPA trajectory (minimum current consumption) by signal injection [1], [32], or perturbing the system and analyzing responses [3], [33]–[35]. These methods are easier, however their dynamics are typically slower, thus they may not be applicable in drives with fast responses.

To summarize, there is a substantial number of approaches to the implementation of MTPA algorithms. Each of them has both advantages and drawbacks; therefore, selection of the exact method strongly depends on the specification of the motor drive under development as well as design targets. The most important

of them, which significantly impacts selection of the MTPA algorithm, is discussed in the following. The development time and qualification of the staff defines the complexity of the possible method and the necessity of its tuning. The target efficiency of the drive affects the ability of the algorithm to track the MTPA trajectory precisely. The desired dynamic response of the drive restricts usage of some online seeking methods, which perturb the system and analyze its response. The design of a motor drive, presence, or absence of sensors and their tolerance significantly affect the precision of the calculations and MTPA algorithm, whose performance depends on the sensing part. However, the main criterion of MTPA algorithm selection is the availability of the motor information in the stage of development. If these data are accessible, which takes place in the development of power converter for one motor or a limited number of motors, some offline methods may be involved. On the other hand, when motor parameters are unknown (or uncertain is too strong), the offline methods are not applicable and only online methods that operate without information on motor parameters may be used. This may be the case, for example, in the development of industrial general-purpose power converters.

Before further discussion, it should be noted that there is a number of designs of SM, see Fig. 1, which have their pros and cons. The direct and quadrature inductances of these machines may be equal [see Fig. 1(a) and (g)] or not, where in the last case the direct inductance can be less than quadrature inductance [see Fig. 1(b), (c), (h), and (i)] and vice versa [see Fig. 1(d)–(f) and (j)]. Therefore, the statement in [36] of a quadrature inductance always greater than the direct one can easily mislead a reader to choose the wrong MTPA implementations. It is definitely the most popular case, especially in SM with magnets, but there are many machines, where the direct inductance is greater than the quadrature inductance and this fact may not be ignored.

It should be noted that there are several works reviewing MTPA technologies that have been published recently [27], [37]; however, they do not cover the topic completely and overlook several important approaches, possibly due to conference paper length policies. Therefore, it was decided to prepare a journal paper with comprehensive review, which considers existing MTPA techniques, classify them, and discuss the pros and cons.

## II. MOTOR MODEL AND MTPA FORMULATION

The motor model in the synchronous reference frame is

$$\vec{u}_{dq} = R_s \vec{i}_{dq} + \frac{d\vec{\lambda}_{dq}(i_d, i_q)}{dt} + \omega_e \mathbf{K} \cdot \vec{\lambda}_{dq}(i_d, i_q) \quad (1)$$

where  $\vec{u}_{dq} = [u_d, u_q]^T$ ,  $\vec{i}_{dq} = [i_d, i_q]^T$ , and  $\vec{\lambda}_{dq}(i_d, i_q) = [\lambda_d(i_d, i_q), \lambda_q(i_d, i_q)]^T$  are the stator voltages, currents, and magnetic flux linkages, respectively;  $R_s$  is the stator resistance;  $\omega_e = p\omega_m$  is the electrical speed obtained by multiplying the mechanical speed  $\omega_m$  and the number of pole pairs  $p$ . The matrix  $\mathbf{K} = \begin{bmatrix} 0 & -1 \\ 1 & 0 \end{bmatrix}$  corresponds to a rotation of  $\pi/2$ . It is worth highlighting the dependence of the fluxes  $\vec{\lambda}_{dq}$  on both  $i_d$  and  $i_q$  currents, which is further omitted for simplicity. The dependence of magnetic flux linkage of one axis on the current of the other

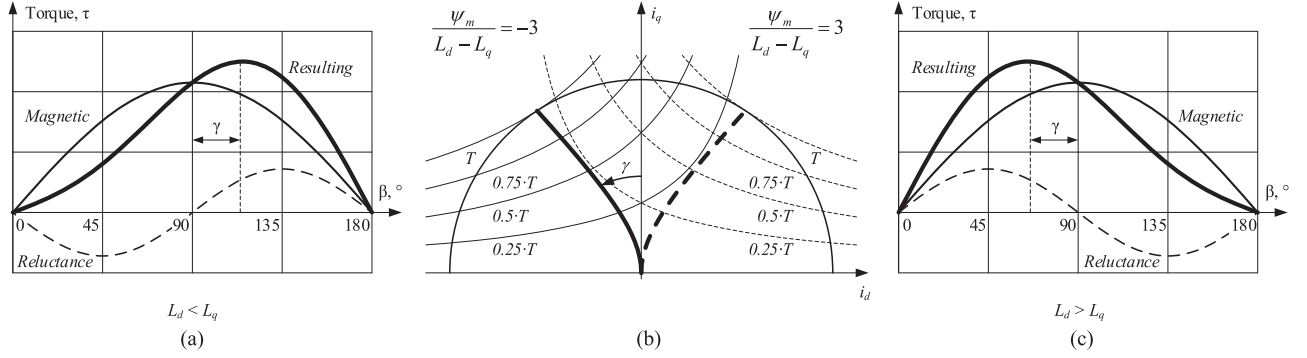

Fig. 2. Torque characteristics of SM. (a) Torque with  $L_d < L_q$ . (b) MTPA characteristics (dotted for case c). (c) Torque with  $L_d > L_q$ .

axis is called cross-saturation (or cross-coupling). The nonideal characteristic of the iron magnetic behavior, which turns out in the magnetic saturation, is responsible for the motor model nonlinearity. Finally, the voltages and currents are function of time  $t$ , although the argument ( $t$ ) was neglected in (1), and it will not be shown in the following for ease of reading.

The general model in (1) leads to the general torque formula

$$\tau(i_d, i_q) = 1.5p(\lambda_d i_d - \lambda_q i_q) \quad (2)$$

which neglects only the cogging torque and the position-dependent terms, mainly due to stator and rotor slotting effects. On the one hand, PM motors are affected by the interaction between the magnets and the stator teeth. On the other hand, reluctance motors suffer from the interaction between the spatial harmonics of electrical loading and the rotor anisotropy. However, those terms do not affect the mean torque production, and thus neither the MTPA operations.

The  $dq$  quantities can be also represented in polar coordinates, e.g.,  $i_d = I_s \cos(\beta)$  and  $i_q = I_s \sin(\beta)$ , where  $I_s = \|\vec{i}_{dq}\|$  is the current space vector magnitude,  $\|\cdot\|$  is the Euclidean norm operator, and  $\beta = \arg(i_q/i_d)$  is the current space vector phase in the synchronous reference frame. The polar quantities turn out very convenient in some MTPA algorithms.

A simplified model is obtained by neglecting the magnetic iron and cross-saturations in (1) and (2), which returns the following torque expression:

$$\tau = 1.5p[\Lambda_{mg} i_q + (L_d - L_q) i_d i_q] \quad (3)$$

where the magnetic flux linkages are simply approximated by linear functions, i.e.,  $\lambda_d = L_d i_d + \Lambda_{mg}$  and  $\lambda_q = L_q i_q$ , where  $L_d$  and  $L_q$  are the  $d$ - and  $q$ -axis apparent inductance, respectively. Equation (3) has the merit of clearly showing the two torque components, i.e., the magnetic and reluctance ones, as sketched in Fig. 2(a) and (c). An attempt to consider the nonlinear behaviour of the flux-current relationships is to express the apparent inductances as function of both current, i.e.,  $L_d(i_d, i_q)$  and  $L_q(i_d, i_q)$ . However, a constant term  $\Lambda_{mg}$  poses the problem of calculating  $L_d(0, i_q)$ . A solution is to consider the PM flux linkage as function of the  $q$ -axis current, i.e.,  $\Lambda_{mg}(0, i_q)$  (see [38]).

### A. Problem Statement

A generic torque value can be obtained by an infinite combination of the pair  $(i_d, i_q)$ . In order to obtain only one combination of  $(i_d, i_q)$ , a constraint can be used to reduce the number of solutions at one. The choice analyzed in this article is the MTPA, aiming at minimizing the copper losses. The MTPA condition is obtained by searching the maximum torque-to-current ratio for each desired torque value. In the following, only  $i_q > 0$  ( $i_q < 0$ ) will be considered for producing positive (negative) torque. The problem statement is described by the following nonlinear optimization problem:

$$\min_{i_d, i_q} \|i_{dq}\| \quad \text{s.t.} \quad \tau(i_d, i_q) = \tau^* \quad (4)$$

where  $\tau^*$  is the desired torque. The MTPA curve is defined by the set of  $(i_d, i_q)$  that satisfy (4) such that  $\|\vec{i}_{dq}\| \in [0, I_{\max}]$ , where  $I_{\max}$  is equal or higher than the nominal current value. An example of the MTPA curve is reported in Fig. 2(b), which includes also the constant torque  $T$  curves.

The solution of (4) is obtained by using the Lagrangian multiplier  $\ell$ , thus searching for the stationary points of the Lagrangian

$$\mathcal{L}(i_d, i_q, \ell) = \sqrt{i_d^2 + i_q^2} + \ell(\tau(i_d, i_q) - \tau^*). \quad (5)$$

The desired solution can be found from

$$i_q \frac{\partial \tau}{\partial i_d} - i_d \frac{\partial \tau}{\partial i_q} = 0. \quad (6)$$

The trivial solution  $i_d = i_q = 0$  is discarded, thus leaving the only applicable solution that is both derivative terms  $\partial \tau / \partial i_d$  and  $\partial \tau / \partial i_q$  identically null (see [37] and [39]). It is worth highlighting that  $\partial \tau / \partial i_d = 0$  for isotropic motors, and thus the MTPA operations are obtained if and only if  $i_d = 0$ .

The optimization problem in (4) can be recast to be described in polar coordinates, i.e.,

$$\min_{\beta} I_s \quad \text{s.t.} \quad \tau(I, \beta) = \tau^*. \quad (7)$$

Among the three possible solutions, the most useful solutions are

$$\frac{\partial \tau}{\partial I_s} = \frac{\partial \tau}{\partial i_d} \frac{\partial i_d}{\partial I_s} = 0 \quad (8)$$

$$\frac{\partial \tau}{\partial \beta} = 0. \quad (9)$$

The current phase angle satisfying (9) is denoted as  $\gamma = \arg(i_d/i_q)$  (see Fig. 2).

### B. MTPA Formulation: Linear Flux-Current Relationships

The most popular MTPA formulation can be obtained by adopting (3) in (8) noting that it suffices  $\partial \tau / \partial i_d = 0$ . It is enough to recall that  $i_q = \sqrt{I_s^2 - i_d^2}$ . The motor parameters are assumed to be constant, and thus the applicable MTPA condition is obtained by

$$i_d = \frac{\Lambda_{mg} - \sqrt{\Lambda_{mg}^2 + 8(L_d - L_q)^2 I_s^2}}{4(L_q - L_d)}. \quad (10)$$

The adoption of  $L_d(i_d, i_q)$ ,  $L_q(i_d, i_q)$ , and  $\Lambda_{mg}(0, i_q)$  does not allow (10) to be considered the correct MTPA expression in the case of nonlinear flux-current relationships. In fact, (10) was obtained from (8) by considering  $L_d$ ,  $L_q$ , and  $\Lambda_{mg}$  as constants, without their dependence on the currents  $(i_d, i_q)$ .

### C. MTPA Formulation: Nonlinear Flux-Current Relationships

The MTPA formulation can be obtained by adopting (2) in (9) and considering the polar representation of the  $dq$  currents. After some tedious calculations, one obtains [39], [40]

$$2l_{dq}i_d i_q - (l_d i_q^2 + l_q i_d^2) + L_d i_d^2 + L_q i_q^2 + \Lambda_{mg} i_d = 0 \quad (11)$$

where the differential inductances are defined as

$$l_d(i_d, i_q) = \frac{\partial \lambda_d(i_d, i_q)}{\partial i_d}, \quad l_q(i_d, i_q) = \frac{\partial \lambda_q(i_d, i_q)}{\partial i_q} \quad (12)$$

and the cross-differential inductances, see [41], are defined as

$$l_{dq}(i_d, i_q) = l_{qd}(i_d, i_q) = \frac{\partial \lambda_d(i_d, i_q)}{\partial i_q} = \frac{\partial \lambda_q(i_d, i_q)}{\partial i_d}. \quad (13)$$

The current dependences of the apparent inductances and PM flux linkage are omitted in (11) for the sake of space reduction. Equation (11) holds for SynR motors as well by considering  $\Lambda_{mg}(0, i_q) = 0 \forall i_q \in \mathbb{R}$ . It is worth noting that considering null values for all differential inductances and assuming constant values of apparent inductances, and PM flux linkage in (11), one easily obtains (10).

### D. MTPA Formulation From Torque Measurement

In some cases, the availability of torque measurements carried out on dedicated test rigs and specifically designed tests return an alternative way for finding the MTPA curve. A different problem statement, alternative to (4), is often adopted, i.e.,

$$\max_{\beta} \tau(I_s, \beta) \quad \text{s.t.} \quad I_s = I_s^* \quad (14)$$

where  $I_s^*$  is the desired current magnitude. Both (4) and (14) lead to the same result, i.e., to the same MTPA condition following the Lagrangian multiplier approach. In turn, the MTPA solution is searched by means of interpolation algorithms between

measurement data at different values of the current magnitude  $I_s^*$ .

### E. Peculiar MTPA Formulations in Scientific Literature

In the literature, several peculiar solutions to the MTPA formulation could be found, although all of them can be classified as the Lagrangian approach, as described in Section II-A. For the sake of generality, some interesting results are worth being reported, as discussed hereafter.

The use of quadrics in [42] allowed to pose a very elegant problem statement, which includes even flux-weakening, maximum torque-per-flux, and maximum torque-per-voltage operations. Furthermore, magnetic saturation and cross-coupling were included. The solution to the MTPA problem is suitable for offline and online operations, provided that the steady-state condition is guaranteed. The work of [42] is very general, provided that the motor model is known.

The impact of the iron losses is often neglected. Iron losses are expected to be relevant at high frequencies, thus low-speed operations are little affected, which can be clearly seen from the simple model described in [43]

$$w_i = w_{ie} + w_{ih} = K_e f^2 B_{\max}^2 + K_h f B_{\max}^2 \quad (15)$$

where  $w_i$ ,  $w_{ie}$ , and  $w_{ih}$  are the core loss per weight, eddy current, and hysteresis losses per weight, respectively;  $K_e$  and  $K_h$  are the experimental constants obtained by the Epstein frame;  $f$  is the frequency of the alternating magnetic field; and  $B_{\max}$  is the maximum flux density during the time interval.

One of the first attempts to account for iron losses is reported in [44], where the iron losses effects are described by means of an equivalent resistance  $R_i$ . A modified torque equation (2), accounting for the presence of the iron losses, was proposed and adopted in the problem statement (4). The solution proposed in [42] paves the way to account the iron losses, too.

The temperature variation affects the amount of PM flux linkage to the stator windings. Thus, torque is affected, as well, however this aspect is seldom considered. A tentative was made in [45] by means of polynomial approximation of the PM flux linkage  $\Lambda_{mg}(0, i_q, T^\circ)$ , where  $T^\circ$  represents the temperature. The polynomial approximation was applied in (5), returning an MTPA formulation that accounts for temperature variation effects on  $\Lambda_{mg}$ .

## III. CLASSIFICATION

The proposed classification for MTPA control algorithms and methods is shown in Fig. 3. It enhances the classification proposed in [27] and [37] and includes methods found in the latest publications and algorithms, which have been developed by the authors of this article. A substantial part of these algorithms has been checked in laboratories and some of them were put into mass production for industrial, commercial, and consumer drives. The lowercase letters in rectangles right to the methods indicate the changes to the conventional vector control (VC) scheme shown in Fig. 4, which are necessary for the implementation of the corresponding method. These changes are



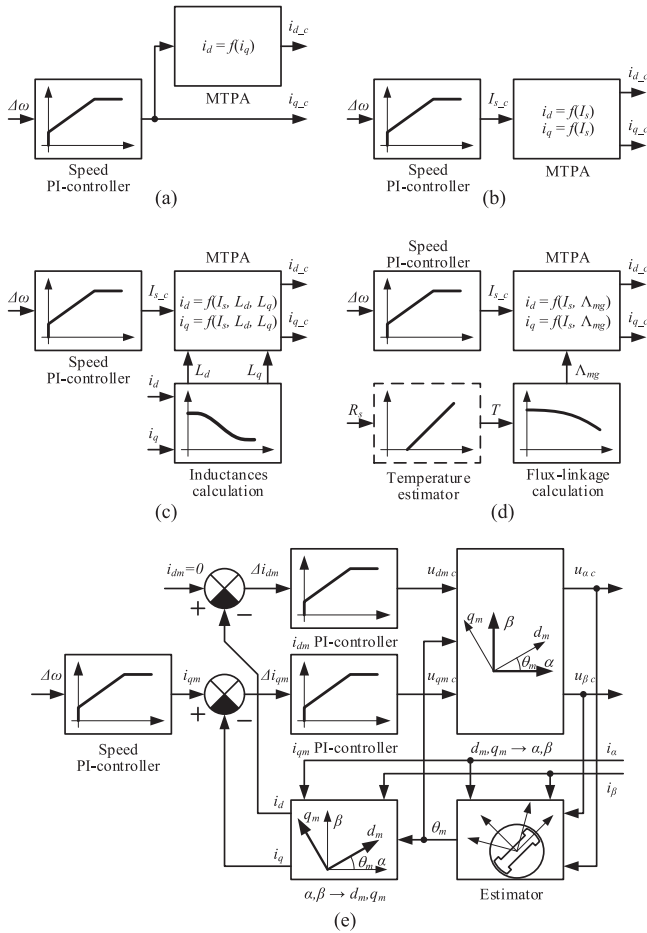

Fig. 5. Modifications of the conventional control scheme for implementation of MTPA offline methods. (a) and (b) Analytical approach. (c) Inductance calculation as a function of current. (d) Flux-linkage calculation as a function of temperature. (e) Motor parameters calculation in the MTC reference frame.

control of isotropic motor, where  $L_d = L_q$ . This control scheme is frequently used for the control of surface mounted permanent magnet synchronous machines (SMPMSM) without saturation, therefore it is considered as a conventional VC scheme of SMPMSM.

This conventional control scheme shown in Fig. 4 receives the speed command  $\omega_{ref}$  and calculates speed error  $\Delta\omega$  using motor speed  $\omega$  received from the speed calculator, which processes signals from the position sensor. Then, the calculated speed error is processed by the speed controller, which outputs commanded value of the quadrature current  $i_{q,c}$ . The commanded value of the direct current  $i_{d,c}$  is set to zero. After that, the current errors  $\Delta i_d$  and  $\Delta i_q$  are calculated using measured motor phase currents, typically  $i_a$  and  $i_c$ , which are transformed into stationary reference frame  $\alpha\beta$  and then into rotational reference frame  $dq$  using information from the position sensor. Then, current errors are sent to the current controllers, which produce commands for stator voltages  $u_{d,c}$  and  $u_{q,c}$ . After that, commanded voltages are transformed into the stationary reference frame and sent to the space vector pulsewidth modulation (SVPWM) block, which calculates duty factors for inverter switches and outputs corresponding signals.

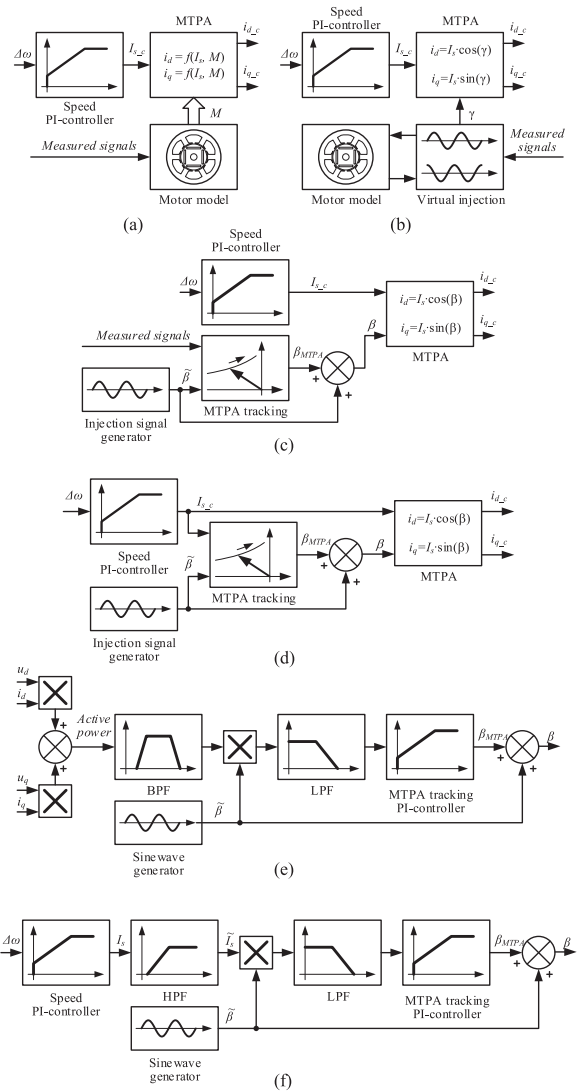

Fig. 6. Modifications of the conventional control scheme for implementation of MTPA online methods. (a) Parameters estimation. (b) Virtual signal injection. (c) and (e) High-frequency injection. (d) and (f) Low-frequency injection.

The conventional VC scheme of SMPMSM is used as a basic scheme for control of synchronous motors of other types and is extended with additional blocks, depending on the desired control algorithms. The modifications to this basic scheme necessary for the implementation of the offline and online MTPA methods are shown in Figs. 5 and 6, respectively, and are discussed in the following sections in detail.

#### IV. OFFLINE METHODS

This section discusses offline methods of the MTPA control, where all computations of drive characteristics and motor parameters are performed at the stage of the development or commissioning and where control algorithms do not involve any estimation techniques for adjustment to the motor operating conditions.

### A. Analytical Approach-Based Methods

Most of the techniques adopting (10) are classified as *analytical approach-based methods*. These techniques were developed during the early stages of the research about MTPA control. In fact, the iron magnetic saturation is neglected, thus simplifying the mathematical representation and easing the implementation on early industrial microcontrollers. However, most recent techniques are based on optimization methods, which enable the possibility to extend operations, even in the constant power region.

Uddin *et al.* [46] propose the adoption of (10) within the MTPA block of Fig. 5(a). Furthermore, the scheme was augmented by a flux-weakening algorithm based on mathematical relationships, i.e., in the same fashion as for obtaining the MTPA condition. The drawback of this approach lies in the constant motor parameter values assumption. Similar considerations can be drawn also for the technique proposed in [47], where the approximated MTPA condition (10) was slightly modified, taking advantage of the sensorless algorithm structure.

Still (10) was the cornerstone of the technique proposed in [48], in which the output of the speed controller was normalized, with respect to the ratio between the maximum torque and current. This modification helped Pan and Sue [48] in extending the operations of the drive to field-weakening operations. The implementation scheme resembles the one of Fig. 5(b).

The MTPA method proposed in [21] is based on an optimal state criterion, but the motor parameters were calculated at the rated torque value to approximate the effect of magnetic saturation. Thus, the inductances are calculated as function of one current value  $L = f(I_s)$ , where  $I_s$  is set at the rated current value. The MTPA application is thus like the schematic of Fig. 5(b).

For the sake of easier implementation, the MTPA curve obtained by (10) was calculated at different values of inductances in [49] and [50]. The inductances were approximated by a linear model as function of current magnitude. Thereafter, the MTPA curve was transposed in the polar representation, adopting a schematic similar to Fig. 5.

### B. Motor Parameters Calculation

The MTPA techniques adopting the motor parameters calculation can be represented by the control scheme variant of Fig. 5(c). The conventional approach is to carry out an offline commissioning procedure. After collecting the predetermined set of measurements, the motor parameters, or equivalently the polynomial representation of the model in (1), are obtained during the postprocessing phase by best-fitting techniques (e.g., least-square-based algorithms).

The method proposed in [51] adopts lookup tables (LUTs) stored motor parameters to calculate the MTPA curve by means of (10). The magnetic saturation and cross-coupling effects are accounted by calculating the MTPA solution in an iterative way.

Miao *et al.* [52] adopted 12 parameters in order to represent the nonlinear behavior of the magnetic flux linkages in the torque equation (2). Then, the MTPA condition was found by changing the currents reference frame in the polar coordinates and thus applying the problem statement in (7). Indeed, an MTPA

condition very similar to (11) was obtained by changing the electrical currents back to the Cartesian coordinates. A very similar approach was previously adopted in [45], where Rabiei *et al.* suggested to store the MTPA curve into LUTs, or by solving a two-variable nonlinear problem online.

Huang *et al.* [53] and Lee *et al.* [54] implemented a comprehensive motor parameter based MTPA control, also including the temperature effects, iron and mechanical losses. All parameters were obtained offline, and the online measurements are used to calculate the instantaneous values of the parameters. The MTPA curve was precalculated and stored into LUTs, in a similar fashion of Fig. 5(c).

A peculiar approach was adopted in [55]. The MTPA problem was rewritten as a fourth-order polynomial and then the Ferrari's method was used to find the desired solution. The motor parameter variations were considered in calculating the pair  $\vec{i}_{dq}^*(k)$ , corresponding to the MTPA solution. The previous step solution  $\vec{i}_{dq}^*(k-1)$  is used to calculate the values of the apparent inductances  $L_d(i_d, i_q)$  and  $L_q(i_d, i_q)$ , i.e., the parameters  $L = f(i_d, i_q)$  in Fig. 3, and thus solving the MTPA problem computation. It is worth noting that this approach leads to an error, since the differential inductances and the cross-saturation are not considered. The solution proposed in [55] was further developed in [56] by considering the cross-saturation effect, and in [57] for a wounded rotor synchronous motor similar to those in Fig. 1(f).

Numerical algorithms can be used to calculate the solution of MTPA problems such as (4). Their application has become of interest due to the increased computational power offered by the new microprocessors. Furthermore, the complexity of the nonlinear MTPA condition (11) requires numerical algorithms to calculate the desired solutions.

In [39], [44], and [58], the authors computed the solution of the problem (4) was found by means of Newton's method. However, an ill-convergence problem for highly magnetic saturated motors is posed [39]. A complete characterization of the motor and a formulation, including the differential inductances was adopted in [58]. Xia *et al.* [58] claim that the ill-conditioning problem was solved; however, they based their method on the torque equation (3), rather than (2). A Levenberg–Marquardt algorithm was implemented in [59]. The torque was computed as in (2), by means of flux linkages  $\vec{\lambda}_{dq}(i_d, i_q)$  stored into LUTs that were obtained offline. Therefore, the MTPA proposed in [59] falls in the motor parameters-based offline MTPA techniques classification such as all the numerical algorithms based methods [39], [44], [58].

An unusual approach was demonstrated in [60] and [61], where the authors suggested to use maximum torque control (MTC) reference frame  $d_m q_m$ , where  $q_m$  axis is aligned with the stator current vector at the MTPA angle. The authors considered steady-stated mode of motor operation and redefined quadrature axis inductance in the new reference frame as

$$L_{q_m} = L_d + \frac{(L_q - L_d) \left( \frac{\Lambda_m}{\Lambda_r} - \sqrt{\frac{\Lambda_m^2}{\Lambda_r^2} + 1} \right)^2}{\left( \frac{\Lambda_m}{\Lambda_r} - \sqrt{\frac{\Lambda_m^2}{\Lambda_r^2} + 1} \right)^2 + 1} \quad (16)$$

where  $\Lambda_r = (L_q - L_d)i_q$  is a flux caused by motor saliency.

The authors claimed that this parameter is less affected by magnetic saturation than the conventional  $L_q$ , therefore excellent MTPA current loci can be obtained even with  $L_{qm}$  is approximated with a constant value. At the same time, these papers do not provide sufficient experimental results, so this method cannot be evaluated from different points of view. It is unclear how it works in dynamic or on machines, which are highly saturated.

The same approach with using axes other than  $dq$  was proposed in [62] and [63], where the authors adopted MTPA equations for usage in  $MT$  reference frame, where axis  $M$  coincides with stator flux linkage vector. These equations are more complicated than conventional equations; however, the usage of the  $MT$  reference frame makes the implementation of MTPA in direct torque control (DTC) easier. The authors claimed perfect results; however, the behavior of the proposed technique in operation with motor, whose parameters significantly vary, is unclear.

### C. Simplified MTPA

Earliest research works dedicated to the implementation of MTPA considered rectangular control of PM motors, including six step commutations [64]–[66]. Nevertheless, this topic is still interesting and recent works can be found as well [67]–[70]. The authors of these papers suggest to modify the angles of transistors commutations related to electrical position of the rotor, depending on the value of the stator current. It shifts current waveform closer to MTPA trajectory and increases efficiency compared to natural commutation; however, stator current waveform under rectangular control is not a sine, therefore current vector oscillates near the MTPA curve. As a result, the stator RMS current is not minimized as it should be. However, this solution is more efficient than natural commutation; therefore, it is worth utilizing this method within rectangular control. Despite seeming obsolete, rectangular control of PM motors is now adopted in drives with dual operations, i.e., performing vector and rectangular control in different speed ranges [71].

Another simple approach to the implementation of MTPA control was recommended in [72]–[74], where MTPA curve was substituted with a constant angle line. This approximation is natural for unsaturated or slightly saturated SynRM, but Schiferl and Lipo [72] used this substitution for PM machines as well. The approximation such as this, where current phase is a constant, significantly simplifies calculations. However, it prevents system from the full utilization of reluctance torque of a motor. Therefore, the benefits of this algorithm should be carefully compared with fall in efficiency.

The next simplified approximation of MTPA curve was proposed in [75]–[78], where the authors reduced the MTPA equation (10) by expanding it into Taylor's series around zero and neglecting the high-order terms, which resulted in

$$i_d = \frac{L_d - L_q}{\Lambda_{mg}} i_q^2. \quad (17)$$

As it is clearly seen, this equation is easy for calculation and can speed up the execution of the control algorithm. Furthermore, it needs minor modification of the conventional VC scheme, which is shown in Fig. 5(a) or (b), depending on the equation used. At the same time, the main drawback of this approach is an approximation error, which quadratically rises with the increase of current magnitude, i.e., with a distance from the point of approximation.

A similar approach was adopted by Butt *et al.* [79], [80], too, where (10) was used to recalculate (3), then a Taylor approximation of the square root operator allowed the calculation of the  $dq$  current references.

### D. Look-Up Table

The most popular offline methods adopt LUTs. The reasons of their success are manifold. The adoption of LUTs is ease in all the modified control schemes of Fig. 5. The common drawback of these kinds of methods is that they require a costly time-consuming process for commissioning and, often, a dedicated procedure and hardware. In fact, a torque transducer is often necessary. In order to avoid experimental tests, finite-element analysis (FEA) results are sometimes considered [81], [82].

A typical experiment requires that the motor under test is dragged at constant speed, and different currents set  $\vec{i}_{dq}^*$  are tested while measuring the shaft torque at steady-state conditions. The MTPA curve is postcalculated by means of (14) at different current magnitudes  $I_s^*$ . This way, the MTPA problem is not dependent on motor parameters, but the solution precision depends only on the accuracy of the torque transducer. For this reason, this approach is very popular in papers dealing with parameter estimation techniques when it comes to demonstrating the correctness of the proposed techniques. Some examples are [83] and [84]. Furthermore, FEA analysis of new motor prototypes is often validated comparing the MTPA curve obtained from the result of the analysis and the experimental result-based one, for example [85].

The use of a torque transducer is avoided in [86], where a maximum power-per-ampere strategy is approximated to be similar to the MTPA strategy. Furthermore, load transients are considered, showing two alternatives to the control structure of Fig. 5(a).

### E. Scalar Control (SC)

The SC, which is also known as  $V/f$  control, is popular due to its simple structure, low-cost implementation, and absence of position encoder. The conventional SC implements open-loop scheme, where amplitude of the commanded voltage is calculated as a function of the commanded frequency. This dependence in the middle- and high-speed range, where voltage drop across stator resistance is negligible, is typically implemented as  $V/f = const$ , whereas in the low-speed region it includes some compensation terms.

The conventional SC scheme is depicted in Fig. 7, which illustrates simplicity of SC, compared to a conventional VC scheme. At the same time, the most significant drawbacks of SC

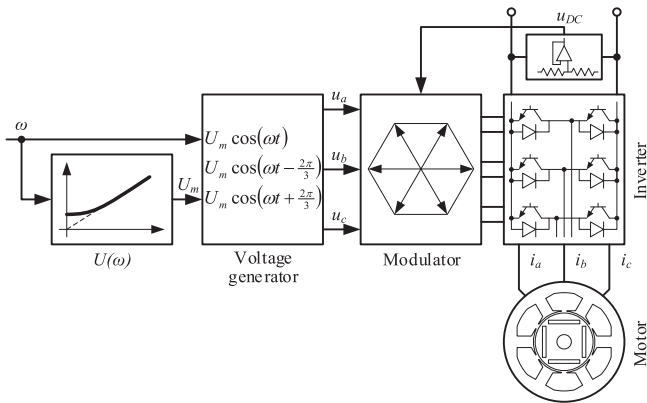

Fig. 7. Conventional SC scheme.

are lower efficiency and stability issues, which decrease areas of its usage. Taking into account the merits of SC, some researchers made efforts to overcome the drawbacks of conventional SC: they focused on speed stabilization, elimination of parasitic oscillations and improvement of drive efficiency.

In order to increase efficiency, an MTPA control has to be implemented. As can be seen from Fig. 7, there are two possible signals that can be impacted for the control of synchronous motors in a scalar scheme: voltage and frequency (angle). The frequency signal is commanded to the system; therefore, its average value should be constant. Simultaneously, commanded signal may be combined with another HF signal, used for stabilization of load angle or disturbance for online tracking of MTPA curve.

Consoli *et al.* [87] and Cacciato *et al.* [88] proposed the use of an additional current sensor in “A” phase of the motor and measured the phase shift between phase voltage and current. Then they suggested to calculate the desired phase shift, which corresponds to the MTPA condition of the motor used. The desired angle is function of motor current, voltage, and speed, providing motor parameters are stable. However, the authors claimed that the desired phase shift mainly depends on the current, and only this dependence may be taken into account. After that, the difference between the real and desired angles is input to the proportional–integral (PI) controller, which modifies the magnitude of the stator voltage.

Another MTPA control algorithm for SC was proposed in [89]–[91], where the reactive power was used in order to follow the MTPA trajectory. The authors calculated in the  $dq$  reference frame desired reactive power, which corresponds to the MTPA condition. After that, they calculated real reactive power in the  $\gamma\delta$  reference frame, where axis  $\delta$  is aligned with stator voltage vector. The difference between desired and real reactive powers is sent to the voltage PI-controller, which modifies the magnitude of the stator voltage.

Tang *et al.* [92] suggested to enhance the conventional SC with estimator of rotor position implemented by integration of the reference speed with corrections. This estimated angle is used for calculation of measured motor currents in  $dq$  reference frame. Then, the authors suggested to use measured quadrature current for calculation of the desired direct current using the

MTPA equation (10). After that, they calculated the difference between the desired and measured direct currents and sent it to the voltage PI controller, which modifies the magnitude of the stator voltage.

Another approach was proposed in [93], where Matsuki and Doki used control scheme of similar topology. The only difference is that they track MTPA trajectory by comparing real and desired currents in  $\gamma\delta$  reference frame.

For the sake of clarity, a comparison of the considered offline techniques is reported in Table I.

## V. ONLINE METHODS

This section discusses online methods for MTPA control, which involves different algorithms to track changes of motor parameters, depending on the operating conditions, e.g., temperature, load, etc. In order to obtain this goal, the main approaches are the estimate of varying motor parameters (for further calculation of MTPA angle) and the direct tracking of the MTPA condition, i.e., extremum seeking (ES).

As already mentioned, parameters and MTPA trajectory may vary during machine operation, due to temperature variation or demagnetization. The adopted machine model may also be too simplistic and fail to capture the saturation phenomena. Moreover, parameters may be known with relevant uncertainty, due to identification errors (e.g., if self-identification is adopted at commissioning) or due to manufacturing tolerance (when data are collected offline, since a limited number of motor samples is tested). All these factors typically result in deviation from the actual MTPA operation, leading to additional losses and decreased torque density. To tackle these issues, various “online” or “adaptive” MTPA techniques have been developed in the last decades. According to these methods, the MTPA operating point is adjusted, based on measurements carried out during the normal operation of the drive.

It is worth noticing that, although many online methods do not rely on prior knowledge of motor parameters, it is possible to use them as a means for refining a single MTPA point, or the whole trajectory, using data gathered offline as a starting point.

As in all cases where online adaptation and/or closed-loop operation are involved, dynamics is an important aspect in online MTPA techniques. In general, some tuning is required in order to achieve correct operation, thus it can be observed that a tradeoff exists between robustness/stability on one side and responsiveness on the other, in which the ideal balancing mainly depends on the specific end-use. As an example, continuous-duty applications such as pumps and fans (which account for a significant portion of electrical consumption [94]), strongly benefit from efficiency improvements. For this reason, there is a demand for simple methods that can minimize energy consumption (even in the presence of parameters uncertainty), whereas dynamical requirements are usually relaxed.

### A. Parameters Estimation

A common approach to the adaptation of MTPA trajectory during normal operation is based on parameters estimation [3], [95]–[102]. In this case, the MTPA operating point is determined

TABLE I  
SUM-UP OF OFFLINE MTPA TECHNIQUES CHARACTERISTICS

Methods Details	Analytical	Parameter calculation	Simplified	Scalar		
				Angular	Reactive power	$d$ current
Papers	[21, 46 - 50]	[51 - 63]	[64 - 80]	[87, 88]	[89-91]	[92]
Principle of operation	MTPA trajectory is obtained from motor equations analytically.	Motor parameters are calculated via predefined formulae using stator current and temperature. Analytical MTPA equation is used.	MTPA curve is approximated with a simplified function or look-up table.	Controls phase shift between phase current and voltage to be equal to value, which corresponds to MTPA.	Controls reactive power to be equal to value, which corresponds to MTPA.	Controls direct current to be equal to value, which corresponds to MTPA.
Disadvantages	Motor parameters are considered to be constant. Their variation is not taken into account.	Does not take motor parameter derivatives into account. Requires preliminary experiments to identify dependencies of motor parameters. Could be hard in tuning. Some algorithms are computation intensive.	Does not reproduce exact MTPA trajectory. The full potential of motor is not used. Requires preliminary experiments to construct approximation function.	The dependence of phase shift between phase current and voltage on motor speed and voltage amplitude is neglected. Motor parameters variation is not taken into account.	Motor parameters variation is not taken into account.	Motor parameters variation is not taken into account. Implementation of a rotor position estimator is required.
Advantages	Easy in tuning and simple implementation. No additional experiments required.	Takes slow motor parameter variation into account. Some methods are easy in tuning.	Extremely simple in implementation and calculations.	Simple algorithm. Significantly improves performance of motor under scalar control.	Simple algorithm. Significantly improves performance of motor under scalar control.	Significantly improves performance of motor under scalar control.

analytically, applying traditional formulae, e.g., (10), but the parameter values ( $L_d$ ,  $L_q$ ,  $\Lambda_{mg}$ ) are estimated online (based on signals measured by the controller). Since equation like (10) is derived considering parameters as constants, when the same parameters are varied online, some terms in the derivatives of torque (8), (9) are neglected, leading to an intrinsic error. However, these techniques typically improve the torque versus current ratio, with respect to offline methods.

Online estimation of motor parameters is a popular topic in the literature, due to its practical impact and inherent challenges. In general, any method for online estimation of motor parameters could be used for MTPA adaptation, but some proposals specifically address the problem of parametric uncertainty with respect to MTPA.

In fundamental-based estimation, the signals that are normally available in the controller (so-called “fundamental”), i.e., typically voltage, current, and speed are processed, with no direct control action performed. Various approaches have been proposed, ranging from observers such as the extended Kalman filter [102] to recursive least squares (RLS) [99] and affine projection algorithm (APA) [96], also including implementations of the model reference adaptive system (MRAS) [103].

As already mentioned, estimation methods require careful implementation and tuning, since noise and stability play a crucial role. Moreover, although estimating all magnetic motor parameters would be required, this is not possible under all operating conditions (without any form of signal injection), so a reduced set of parameters is usually updated. In some cases, e.g., [95], saturation on the  $d$ -axis is neglected, so that only the  $q$ -axis inductance is adapted online. This simplistic approach is usually effective for IPM machines where mild magnetic saturation occurs. However, a complete estimation of parameters is possible, although not trivial [96]. The proposals [100], [104], [105] allow the full flux-linkage maps to be updated online, relying on artificial neural networks (ANN). In this case, initial data and related nonoptimal MTPA trajectory can be improved gradually, based on values obtained at different operating points.

In general, when attempting the online estimation of all parameters involved in MTPA determination, observability issues

arise, also considering the variability of stator resistance [101]. A straightforward solution to this problem is “signal injection,” i.e., the controller and converter system are exploited for applying additional stimuli to the motor, specifically for parameters estimation [106]–[108]. In principle, any of these methods could be exploited for adjusting the MTPA point, based on the analytical formulas and estimated parameters. However, small-signal injection can only estimate differential inductances, which is typically not sufficient for determining the MTPA point. In [98], fundamental-based estimation is enhanced with signal injection (staircase-shaped  $d$ -axis variation), in order to tackle observability and stability issues. A peculiar implementation of RLS is adopted, with fast update of inductance estimates and lower-rate estimation of resistance and PM flux-linkage. An interesting solution to the same issues is proposed in [109], involving the adaptive linear neuron neural network algorithm. Since the method mainly targets traction applications, a procedure is set up so that current pulses are injected (for stator resistance and PM flux-linkage estimation) only during idle operation of the vehicle, whereas inductance values are continuously updated using fundamental-based estimation.

It is worth noticing that signal injection causes disturbance to the normal control, additional losses and, in many cases, increased acoustic noise. However, in some cases, signal injection is also applied for sensorless control, so it can be used for both purposes, i.e., estimation of rotor position and speed together with motor parameters for MTPA adaptation, as demonstrated in [110], using square-wave “rotating” voltage.

### B. Extremum Seeking

A completely different approach is where the operating point is adjusted in a closed-loop fashion, aiming at tracking the MTPA point, with no direct reference to the analytical motor model and related parameters. The operating principle of this kind of method can be considered an application of ES, which is “a method for real-time nonmodel-based optimization” [111]. The main idea is to apply a perturbation of the current vector reference, for “testing” purposes, during the normal operation of

the drive. The response to such stimulus is analyzed searching for the minimum of current, (at given load) or maximum of torque (at given current).

A common characteristic of online seeking methods is that accuracy of the MTPA point estimation does not depend on the knowledge of the machine model or parameters, since the result (point of maximum-torque or minimum-current) is tested by interacting with the machine. However, all the MTPA seeking techniques theoretically rely on the load torque being constant (or slowly-varying); thus, in certain cases they are enabled only at steady state [112]. However, the robustness of certain methods with respect to moderate load transients has been demonstrated [3], [113]. A general solution, which is often adopted in online methods, is to use a feedforward, based on any conventional MTPA implementation [114] so that the online seeking only acts as a fine tuning. Given the closed-loop nature of these methods, stability concerns arise, and need to be addressed with proper design of gains and filtering [113], [115], [116].

The main group of methods in this class is commonly known as “MTPA tracking,” which was proposed more than a decade ago [117]. In the earlier works [112], [114], [117], [118], signal injection was applied at relatively “high-frequency” (HF), aiming at estimating the local derivative of torque, at constant-current. Since the MTPA condition (expressed as maximum torque at given current) corresponds to null derivative, the operating point is moved toward the MTPA, based on a feedback signal (mainly according to the sign of estimated derivative). In this case, the current vector *angle* (or, equivalently, orthogonal current component) is typically modified by adding a small sinusoidal signal at a frequency well above the fundamental and, in particular higher than the speed control bandwidth (e.g., hundreds of hertz) so that its effect is *not* rejected by the speed control loop. Considering mechanical steady-state conditions, the current vector magnitude remains almost constant, leading to torque oscillations. In [114] and [117], said variations are detected through processing (demodulation) of speed measurement, whereas Bolognani *et al.* [112] and Kim *et al.* [118] propose processing of the estimated motor active power [i.e., obtained from voltage and current signals normally available to the controller, Fig. 6(e)]. In fact, using the well-known “small-signal” approach (i.e., first-order Taylor series approximation), at constant-current, torque variations  $\tilde{\tau}$  are only due to angle perturbation  $\tilde{\beta}$

$$\tilde{\tau} \approx \frac{d\tau}{d\beta} \tilde{\beta}. \quad (18)$$

It can be shown that a signal proportional to the derivative in (18) can be extracted by demodulating the speed or active power, i.e., evaluating their first harmonic component. The resulting signals are used as an “out-of-MTPA” error indicator, which crosses zero at the MTPA. As shown in Fig. 6(e), this signal is fed to a PI regulator, for being controlled to zero by adjusting the steady-state current vector angle.

It should be noted that HF current injection requires special care in the tuning of current controllers and/or the use of resonant controllers in addition to typical PI controllers [118], in order to obtain high-accuracy current regulation, even at the

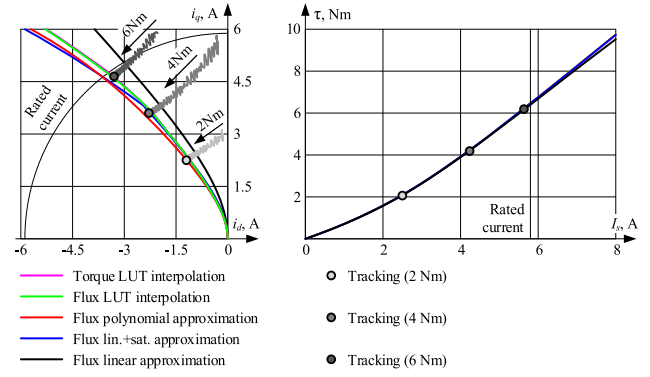

Fig. 8. Comparison of MTPA tracking and offline MTPA trajectories based on torque measurements, flux measurements, or flux maps approximations.

injection frequency. Moreover, if the feedback for correcting MTPA is taken in terms of speed oscillation, a medium- to high-performance position sensor is required [114]. On the other hand, if the tracking is based on active power, operation below a certain speed is prevented by the low signal-to-noise ratio [112].

Antonello *et al.* [119] proposed a different operating principle for MTPA tracking, based on injection at “low-frequency” (LF) and on evaluation of the derivative of current magnitude (at constant-torque). Similarly to the HF injection, the steady-state current vector angle is modified by the superposition of a small-amplitude sinusoidal signal. However, in this case, injection frequency must be within the speed control bandwidth, hence the classification of the technique as “LF” injection. In fact, at constant load, thanks to the disturbance rejection provided by the speed regulator, torque produced by the motor dynamically balances the load torque, whereas the effect of injection is compensated by amplitude variations in the speed regulator output. In this way, the current vector moves along a small portion of a constant-torque curve, whereas current magnitude varies because of the commanded angle variation. Following the small-signal approach, the current vector magnitude can be approximated as a sinusoid  $\tilde{i}_s$ , added to the steady-state value [see Fig. 6(c)], i.e.,

$$\tilde{i}_s \approx \frac{di_s}{d\beta} \tilde{\beta}. \quad (19)$$

The MTPA condition pursued is minimum current for given torque (4), which is reached when derivative in (19) is null. In order to evaluate the derivative, demodulation is applied to the current magnitude signal, which is available within the controller and the demodulated signal is exploited as an “out-of-MTPA” error signal (similarly to what is done with “HF” injection). Fig. 8 shows that the phase of  $\tilde{i}_s$  inverts when crossing the MTPA point and so does the demodulated signal. For this reason, forcing the error signal to zero corresponds to tracking the MTPA, which is achieved by means of a feedback loop [see Fig. 6(f)], i.e., the steady-state current vector angle is the output of a PI regulator. It is worth mentioning that this technique involves the speed regulator, so it is not suitable for pure torque control or when torque limitation occurs. Further limitations

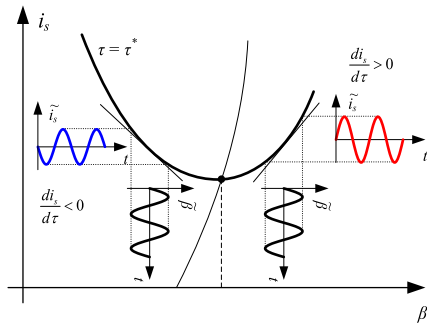

Fig. 9. Small-signal approach for MTPA tracking according to the “LF” injection method.

include very low-torque operation [113], although this issue is expected to affect all MTPA tracking methods.

Fig. 9 shows an example of MTPA tracking using LF injection. Gray traces (left) represent the evolution between initial and final current vector, at three different load values. The same figure also compares different MTPA curves obtained offline, based on various methods, namely torque measurements, flux maps, and flux approximations (polynomial, “linear+saturation” [120] and constant inductance) for an IPMSM. As already shown in [95], the torque versus current characteristic is a convenient way for comparing the effectiveness of different MTPA solutions since it clearly reveals how a nonoptimal MTPA trajectory results in loss of available torque (at a certain maximum current) and excess of current needed (for obtaining a certain torque). On the other hand, simple comparison between trajectories on the  $I_d I_q$  plane (see Fig. 9) does not represent the practical impact of MTPA error.

Recently, virtual signal injection control (VSIC) [121]–[124] has been proposed as an alternative to real signal injection. The MTPA tracking schematic adopted in this case is *similar* to the one used for “HF” injection, but no signal is actually injected. In fact, the technique estimates the torque derivative (18), based on local values of voltage, current and speed, i.e., the loop does not involve the real feedback from the machine. From this point of view, the method could be classified as based on parameters estimation, rather than injection-based. The method has the advantage of avoiding additional losses, disturbance and acoustic noise related to injection. On the other hand, it requires speed to be sufficiently high (since voltage is involved in estimating the derivative) and relies on the knowledge of  $d$ -axis inductance (considered constant). Moreover, the technique suffers from an implicit MTPA angle error, which becomes relevant if inductances vary strongly with current. This accuracy issue has been characterized and discussed by the same authors who proposed the VSIC principle [125], [127]. A comparison between VSIC and “real” signal injection methods (i.e., “HF” and “LF” injection) is also reported in [126].

Perturb and Observe (P&O) techniques [3], [11], [33]–[35], [128]–[132] have also been adopted as online MTPA “search” algorithms, resulting in relatively simple implementations. These methods are based on discrete variations of the operating point and evaluation of their effect. In some cases, they are considered faster than other MTPA tracking techniques, e.g., in [133], where

the “Simplex” discrete-search method is compared with “MTPA tracking”. A common drawback is related to the robustness to load variations, which has been addressed in [3], by combining P&O with parameters estimation.

A peculiar MTPA search technique is presented in [134], which can still be considered a P&O method, since it adjusts the MTPA angle in discrete steps. The proposal is based on slow modification of the current reference vector angle, which response is evaluated in order to select the correction to be applied at the next step. Since the current vector angle is varied according to a specific pulse shape and at regular intervals, the authors claim good rejection with respect to variable load torque.

Although most implementations of MTPA tracking have been proposed within typical VC field oriented control (FOC), SC is considered in [135]. The authors suggest injecting HF voltages in  $st$  reference frame, where the  $s$ -axis coincides with the stator current vector, and to analyze the input power of the drive. The processing algorithm tracks zero point of the derivative of input power, which corresponds to the MTPA condition. Similarly, to other MTPA tracking techniques, the authors claim insensitivity to motor parameters variation, combined with the simplicity of scalar approach.

In [1], MTPA tracking has also been proposed for DTC and implemented for SynRMs. The operating principle of the proposal is similar to the one described as LF injection, whereby the disturbance rejection capability of the speed regulation loop is exploited. In this case, a pseudorandom sequence (instead of a sinusoidal signal) is superposed on the flux-linkage reference (instead of the current vector angle). The typical fast response of DTC is exploited, at the same time avoiding a large single-tone from appearing in the torque ripple.

For the sake of clarity, a comparison of all online techniques is reported in Table II.

### C. Synchronous Reluctance Motors

A special case is represented by the SynRM, which does not present any independent source of magnetic flux, e.g., the PMs. To all intent and purposes, the SynRMs present the same reluctance torque formulation as the PMSMs, thus the MTPA condition can be obtained in the same way. Typically, the only difference to be considered is the  $d$ -axis position, which is usually posed along the position with the highest reluctance value, but the same equations and considerations in Section II hold. As a consequence of this choice for the axes, positive  $d$ -axis current is imposed during operation, i.e., the MTPA curve for positive torque lies in the first quadrant of the  $dq$  current axes (while it is in the third quadrant for IPMSMs).

The offline MTPA approach is often adopted for SynRM drives, such as the simplified approach reported in Section IV-C, which corresponds to considering the motor inductances as constant values. In turn, the efficiency of the drive is sacrificed in favor of control structure simplicity. However, recent research contributions for these motors have been proposed as online techniques, and many others are expected to appear due to the increasing popularity of SynRM [13]. Adaptive techniques seem quite promising because they are based on the motor

TABLE II  
SUM-UP OF ONLINE MTPA TECHNIQUES CHARACTERISTICS

Methods	Parameters estimation		Extremum seeking			
	Fundamental based	Signal injection	Signal injection		Perturb & Observe	
Details			Low-frequency	High-frequency	Virtual signal injection.	Perturb & Observe
Papers	[95, 96, 98, 99, 102-105]	[106-110]	[111-118]	[95, 119, 120]	[121-127]	[3, 11, 33-35, 128-132]
Principle of operation	Estimated parameters are used in MTPA formulas (open-loop). Virtually, any online estimation method can be exploited (e.g. EKF, RLS, APA, MRAS, ANN, ...)		Persistent current angle variation min. current is pursued (closed-loop)	Persistent current angle variation; max. torque is pursued (closed-loop)	Torque vs. angle derivative is estimated based on fundamental signals (open-loop)	Operating point is varied arbitrarily and effect evaluated; min. current is pursued
Disadvantages	Observability of all parameters is critical, knowledge of some parameters may be needed. Low accuracy of estimated MTPA (especially in highly saturated motors) when using (10).	Convergence rate and/or filtering is critical for stability. Torque disturbance due to injected signals. Low accuracy of estimated MTPA (especially in highly saturated motors) when using (10).	Additional design of a feedback control loop. Only applicable in speed control (torque control only is not possible). Acoustic noise mainly during transients.	Additional design of a feedback control loop. Signal-to-noise issues at low-speed. Current control design requires particular care. Acoustic noise and small additional losses.	Knowledge of some motor parameters is required. Signal-to-noise issues at low-speed. Implicit MTPA angle error for highly saturated motors.	Slow convergence to the MTPA point. Very sensitive to load variations, identification of steady-state condition may be required.
Advantages	No vibration or acoustic noise, no additional losses.	Signal injection could be also used for sensorless control.	True MTPA seeking with high accuracy. Low sensitivity to load variation. Simple to implement. Ideally no torque oscillation.	True MTPA seeking with high accuracy.	No vibration or acoustic noise, no additional losses. Virtually wide-bandwidth tracking.	True MTPA seeking. Simple to implement. Limited or no vibration or acoustic noise, no additional losses.

parameter variations estimation. Recent examples involve the use of advanced parameter estimation techniques, such as *neural networks* in [100], [131], [132], advanced flux observers as in [137] or online inductance estimation as in [138]. However, signal injection techniques are still possible for SynRM, as reported in [1].

## VI. CONCLUSION

MTPA control is an indispensable part in the control of high-efficient motors, which allows full utilization of the motor torque. Therefore, it has been a very popular topic for researchers dealing with modern electrical drives and its importance has grown, together with the concern of efficiency. As a result, a large number of techniques and algorithms have been proposed.

In this review, the most significant papers regarding MTPA control have been considered. The concept of MTPA has been introduced, together with the main definitions required for analyzing the problem. The different implementations have been described, classified, and analyzed in their distinctive features, pros, cons, and possible areas of usage, based on the literature and on the authors' experience. The article aims at providing a comprehensive source of information on the MTPA topic, for orientation of researchers and practitioners in the field. Given the space constraints, only brief descriptions could be included, but detailed information can be easily obtained from the extensive list of references.

At the same time, it is evident that further study and comparison of the considered methods to each other in similar condition are encouraged. Therefore, the authors are working on a series of papers, dedicated to detailed and comparative analyses of the discussed techniques. Each paper will consider a group of MTPA algorithms from Fig. 3 and will report comparative experimental results obtained in two motor drives, where one drive contains an unsaturated motor and another drive includes a saturated machine. Future works will have to consider that the drives technology moves toward more *artificial intelligence*,

and *data-driven* solutions that may represent new tools for investigating MTPA detection and implementation. The transition from MTPA to flux-weakening and/or maximum torque per voltage control (MTPV) algorithm is still a subject that needs to be further investigated for both offline and online techniques. Another research topic that needs to be investigated is the MTPA algorithm application in sensorless-based drives, whereby the rotor position and speed information will be affected by uncertainties and limited in their dynamics. It is also envisioned that signal injection could be used for both MTPA tracking and position estimation. Finally, the acoustic noise generated by some of the MTPA control techniques should be considered in the future, especially for human-related applications such as automotive applications [136].

## REFERENCES

- [1] S. Bolognani, L. Peretti, and M. Zigliotto, "Online MTPA control strategy for DTC synchronous-reluctance-motor drives," *IEEE Trans. Power Electron.*, vol. 26, no. 1, pp. 20–28, Jan. 2011.
- [2] A. Yousefi-Talouki, P. Pescetto, and G. Pellegrino, "Sensorless direct flux vector control of synchronous reluctance motors including standstill, MTPA, and flux weakening," *IEEE Trans. Ind. Appl.*, vol. 53, no. 4, pp. 3598–3608, Jul. 2017.
- [3] P. Niazi, H. A. Toliyat, and A. Goodarzi, "Robust maximum torque per ampere (MTPA) control of PM-assisted SynRM for traction applications," *IEEE Trans. Veh. Technol.*, vol. 56, no. 4, pp. 1538–1545, Jul. 2007.
- [4] H. Heidari *et al.*, "A review of synchronous reluctance motor-drive advancements," *Sustainability*, vol. 13, no. 2, pp. 1–37, Jan. 2021.
- [5] A. Anuchin *et al.*, "Adaptive efficient control for switch-reluctance drives with DCDC-regulator for inverter supply," in *Proc. EPE Power Electron. Motion Control Conf.*, 2004, pp. 1–5.
- [6] W. Wang and B. Fahimi, "Maximum torque per ampere control of switched reluctance motors," in *Proc. IEEE Energy Convers. Congr. Expo.*, 2012, pp. 4307–4313.
- [7] N. Nakao and K. Akatsu, "Vector control specialized for switched reluctance motor drives," in *Proc. Int. Conf. Elect. Mach.*, 2014, pp. 943–949.
- [8] N. Bianchi and T. M. Jahns, *Design, Analysis, and Control of Interior PM Synchronous Machines*. Padua, Italy: Cleup, 2006.
- [9] E. B. Agamloh, "Power and efficiency measurement of motor-variable-frequency drive systems," *IEEE Trans. Ind. Appl.*, vol. 53, no. 1, pp. 766–773, Jan./Feb. 2017.

- [10] L. Alberti and D. Troncon, "Design of electric motors and power drive systems according to efficiency standards," *IEEE Trans. Ind. Electron.*, vol. 68, no. 10, pp. 9287–9296, Oct. 2021.
- [11] T. Windisch and W. Hofmann, "A novel approach to MTPA tracking control of AC drives in vehicle propulsion systems," *IEEE Trans. Veh. Technol.*, vol. 67, no. 10, pp. 9294–9302, Oct. 2018.
- [12] B. Gallert, G. Choi, K. Lee, X. Jing, and Y. Son, "Maximum efficiency control strategy of PM traction machine drives in GM hybrid and electric vehicles," in *Proc. IEEE Energy Convers. Congr. Expo.*, 2017, pp. 566–571.
- [13] A. T. de Almeida, F. J. T. E. Ferreira, and G. Baoming, "Beyond induction motors—Technology trends to move up efficiency," *IEEE Trans. Ind. Appl.*, vol. 50, no. 3, pp. 2103–2114, May/Jun. 2014.
- [14] S. Stipetic, D. Zarko, and N. Cavar, "Adjustment of rated current and power factor in a synchronous reluctance motor optimally designed for maximum saliency ratio," *IEEE Trans. Ind. Appl.*, vol. 56, no. 3, pp. 2481–2490, May/Jun. 2020.
- [15] W. Sung, J. Shin, and Y. Jeong, "Energy-efficient and robust control for high-performance induction motor drive with an application in electric vehicles," *IEEE Trans. Veh. Technol.*, vol. 61, no. 8, pp. 3394–3405, Oct. 2012.
- [16] H. M. Hesar, H. A. Zarchi, and G. A. Markadeh, "Online MTPA and MTPIA control of brushless doubly fed induction motor drives," *IEEE Trans. Power Electron.*, vol. 36, no. 1, pp. 691–701, Jan. 2021.
- [17] W. Xu, M. F. Elmorshedy, Y. Liu, J. Rodriguez, and C. Garcia, "Maximum thrust per ampere of linear induction machine based on finite-set model predictive direct thrust control," *IEEE Trans. Power Electron.*, vol. 35, no. 7, pp. 7366–7378, Jul. 2020.
- [18] H. M. Hesar, H. A. Zarchi, and M. A. Khoshhava, "Online maximum torque per ampere control for induction motor drives considering iron loss using input–output feedback linearisation," *IET Electr. Power Appl.*, vol. 13, no. 12, pp. 2113–2120, Aug 2019.
- [19] H. R. Mosaddegh and H. A. Zarchi, "Maximum torque per ampere control of brushless doubly fed induction machine using variable structure approach," in *Proc. 22nd Iranian Conf. Elect. Eng.*, 2014, pp. 677–682.
- [20] S. Ademi and M. G. Jovanović, "Vector control methods for brushless doubly fed reluctance machines," *IEEE Trans. Ind. Electron.*, vol. 62, no. 1, pp. 96–104, Jan. 2015.
- [21] M. Preindl and S. Bolognani, "Optimal state reference computation with constrained MTPA criterion for PM motor drives," *IEEE Trans. Power Electron.*, vol. 30, no. 8, pp. 4524–4535, Aug 2015.
- [22] A. Dianov, N. S. Kim, Y. K. Kim, and S. M. Lim, "Substitution of the universal motor drives with electrolytic capacitorless PMSM drives in home appliances," in *Proc. 9th Int. Conf. Power Electron. ECCE Asia*, 2015, pp. 1631–1637.
- [23] P. R. Ghosh, A. Das, and G. Bhuvaneswari, "Impact of inductance variation on the operation of a synchronous reluctance motor connected to a weak grid," *IET Electr. Power Appl.*, vol. 14, no. 10, pp. 1944–1955, Jul. 2020.
- [24] Z. Mynar, P. Vaclavek, and P. Blaha, "Synchronous reluctance motor parameter and state estimation using extended Kalman filter and current derivative measurement," *IEEE Trans. Ind. Electron.*, vol. 68, no. 3, pp. 1972–1981, Mar. 2021.
- [25] A. Vagati, B. Boazzo, P. Guglielmi, and G. Pellegrino, "Design of ferrite-assisted synchronous reluctance machines robust toward demagnetization," *IEEE Trans. Ind. Appl.*, vol. 50, no. 3, pp. 1768–1779, May/Jun. 2014.
- [26] C. L. Jeong, Y. K. Kim, and J. Hur, "Optimized design of PMSM with hybrid-type permanent magnet for improving performance and reliability," *IEEE Trans. Ind. Appl.*, vol. 55, no. 5, pp. 4692–4701, Sep./Oct. 2019.
- [27] Z. Li, D. O'Donnell, W. Li, P. Song, A. Balamurali, and N. C. Kar, "A comprehensive review of state-of-the-art maximum torque per ampere strategies for permanent magnet synchronous motors," in *Proc. 10th Int. Elect. Drives Prod. Conf.*, 2020, pp. 1–8.
- [28] M. Carraro, F. Tinazzi, and M. Zigliotto, "Estimation of the direct-axis inductance in PM synchronous motor drives at standstill," in *Proc. IEEE Int. Conf. Ind. Technol.*, 2013, pp. 313–318.
- [29] P. Phowanna, S. Boonto, and M. Konghirun, "Online parameter identification method for IPMSM drive with MTPA," in *Proc. 18th Int. Conf. Elect. Mach. Syst.*, 2015, pp. 1–6.
- [30] G. Feng, C. Lai, K. Mukherjee, and N. C. Kar, "Online PMSM magnet flux-linkage estimation for rotor magnet condition monitoring using measured speed harmonics," *IEEE Trans. Ind. Appl.*, vol. 53, no. 3, pp. 2786–2794, May/Jun. 2017.
- [31] S. Xiao and A. Griffo, "PWM-based flux linkage and rotor temperature estimations for permanent magnet synchronous machines," *IEEE Trans. Power Electron.*, vol. 35, no. 6, pp. 6061–6069, Jun. 2020.
- [32] R. Antonello, M. Carraro, and M. Zigliotto, "Maximum-torque-per-ampere operation of anisotropic synchronous permanent-magnet motors based on extremum seeking control," *IEEE Trans. Ind. Electron.*, vol. 61, no. 9, pp. 5086–5093, Sep. 2014.
- [33] A. Dianov, Y. K. Kim, S. J. Lee, and S. T. Lee, "Robust self-tuning MTPA algorithm for IPMSM drives," in *Proc. 34th Annu. Conf. Ind. Electron.*, 2008, pp. 1355–1360.
- [34] A. Dianov and A. Anuchin, "Adaptive maximum torque per ampere control of sensorless permanent magnet motor drives," *Energies*, vol. 13, no. 19, Sep. 2020, Art. no. 5071.
- [35] A. Dianov and A. Anuchin, "Adaptive maximum torque per ampere control for IPMSM drives with load varying over mechanical revolution," *IEEE J. Emerg. Sel. Topics Power Electron.*, to be published, doi: [10.1109/JESTPE.2020.3029647](https://doi.org/10.1109/JESTPE.2020.3029647).
- [36] K. Li and Y. Wang, "Maximum torque per ampere (MTPA) control for IPMSM drives based on a variable-equivalent-parameter MTPA control law," *IEEE Trans. Power Electron.*, vol. 34, no. 7, pp. 7092–7102, Jul. 2019.
- [37] F. Tinazzi, S. Bolognani, S. Calligaro, P. Kumarz, R. Petrella, and M. Zigliotto, "Classification and review of MTPA algorithms for synchronous reluctance and interior permanent magnet motor drives," in *Proc. 21st Eur. Conf. Power Electron. Appl.*, 2019, pp. 1–10.
- [38] G. Pellegrino, T. M. Jahns, N. Bianchi, W. L. Soong, and F. Cupertino, *The Rediscovery of Synchronous Reluctance and Ferrite Permanent Magnet Motors*. Berlin, Germany: Springer, 2016.
- [39] J. Bonifacio and R. M. Kennel, "On considering saturation and cross-coupling effects for copper loss minimization on highly anisotropic synchronous machines," *IEEE Trans. Ind. Appl.*, vol. 54, no. 5, pp. 4177–4185, Oct. 2018.
- [40] A. Accetta, M. Cirrincione, M. C. D. Piazza, G. L. Tona, M. Luna, and M. Pucci, "Analytical formulation of a maximum torque per ampere (MTPA) technique for SynRMs considering the magnetic saturation," *IEEE Trans. Ind. Appl.*, vol. 56, no. 4, pp. 3846–3854, Jul./Aug. 2020.
- [41] D. Mingardi, M. Morandini, S. Bolognani, and N. Bianchi, "On the proprieties of the differential cross-saturation inductance in synchronous machines," *IEEE Trans. Ind. Appl.*, vol. 53, no. 2, pp. 991–1000, Mar./Apr. 2017.
- [42] H. Eldeeb *et al.*, "A unified theory for optimal feedforward torque control of anisotropic synchronous machines," *Int. J. Control*, vol. 91, no. 10, pp. 2273–2302, Jun. 2018.
- [43] K. Yamazaki and Y. Seto, "Iron loss analysis of interior permanent-magnet synchronous motors-variation of main loss factors due to driving condition," *IEEE Trans. Ind. Appl.*, vol. 42, no. 54, pp. 1045–1052, Jul./Aug. 2006.
- [44] Y. Jeong, S. Sul, S. Hiti, and K. M. Rahman, "Online minimum-copper-loss control of an interior permanent-magnet synchronous machine for automotive applications," *IEEE Trans. Ind. Appl.*, vol. 42, no. 5, pp. 1222–1229, Sep./Oct. 2006.
- [45] A. Rabiei, T. Thiringer, M. Alatalo, and E. A. Grunditz, "Improved maximum-torque-per-ampere algorithm accounting for core saturation, cross-coupling effect, and temperature for a PMSM intended for vehicular applications," *IEEE Trans. Transp. Electrification*, vol. 2, no. 2, pp. 150–159, Jun. 2016.
- [46] M. N. Uddin, T. S. Radwan, and M. A. Rahman, "Performance of interior permanent magnet motor drive over wide speed range," *IEEE Trans. Energy Convers.*, vol. 17, no. 1, pp. 79–84, Mar. 2002.
- [47] F. J. Lin, Y. C. Hung, J. M. Chen, and C. M. Yeh, "Sensorless IPMSM drive system using saliency back-EMF-based intelligent torque observer with MTPA control," *IEEE Trans. Ind. Informat.*, vol. 10, no. 2, pp. 1226–1241, May 2014.
- [48] C. T. Pan and S. Sue, "A linear maximum torque per ampere control for IPMSM drives over full-speed range," *IEEE Trans. Energy Convers.*, vol. 20, no. 2, pp. 359–366, Jun. 2005.
- [49] A. Dianov, N. S. Kim, and S. M. Lim, "Sensorless starting of horizontal axis washing machines with direct drive," in *Proc. Int. Conf. Elect. Mach. Syst.*, 2013, pp. 1–6.
- [50] A. Dianov, N. S. Kim, and S. M. Lim, "Sensorless starting of direct drive horizontal axis washing machines," *J. Int. Conf. Elect. Mach. Syst.*, vol. 3, no. 2, pp. 148–154, 2014.
- [51] B. Cheng and T. R. Tesch, "Torque feedforward control technique for permanent-magnet synchronous motors," *IEEE Trans. Ind. Electron.*, vol. 57, no. 3, pp. 969–974, Mar. 2010.

- [52] Y. Miao, H. Ge, M. Preindl, J. Ye, B. Cheng, and A. Emadi, "MTPA fitting and torque estimation technique based on a new flux-linkage model for interior-permanent-magnet synchronous machines," *IEEE Trans. Ind. Appl.*, vol. 53, no. 6, pp. 5451–5460, Nov./Dec. 2017.
- [53] W. Huang, Y. Zhang, X. Zhang, and G. Sun, "Accurate torque control of interior permanent magnet synchronous machine," *IEEE Trans. Energy Convers.*, vol. 29, no. 1, pp. 29–37, Mar. 2014.
- [54] J. Lee, K. Nam, S. Choi, and S. Kwon, "Loss-minimizing control of PMSM with the use of polynomial approximations," *IEEE Trans. Power Electron.*, vol. 24, no. 4, pp. 1071–1082, Apr. 2009.
- [55] S. Jung, J. Hong, and K. Nam, "Current minimizing torque control of the IPMSM using Ferrari's method," *IEEE Trans. Power Electron.*, vol. 28, no. 12, pp. 5603–5617, Dec. 2013.
- [56] I. Jeong, B. G. Gu, J. Kim, K. Nam, and Y. Kim, "Inductance estimation of electrically excited synchronous motor via polynomial approximations by least square method," *IEEE Trans. Ind. Appl.*, vol. 51, no. 2, pp. 1526–1537, Mar./Apr. 2015.
- [57] Y. Kim and K. Nam, "Copper-loss-minimizing field current control scheme for wound synchronous machines," *IEEE Trans. Power Electron.*, vol. 32, no. 2, pp. 1335–1345, Feb. 2017.
- [58] Z. Xia, S. Nalakath, R. Tarviridilu-Asl, Y. Sun, J. Wiseman, and A. Emadi, "Online optimal tracking method for interior permanent magnet machines with improved MTPA and MTPV in whole speed and torque ranges," *IEEE Trans. Power Electron.*, vol. 35, no. 9, pp. 9753–9769, Sep. 2020.
- [59] H. S. Kim, Y. Lee, S. K. Sul, J. Yu, and J. Oh, "Online MTPA control of IPMSM based on robust numerical optimization technique," *IEEE Trans. Ind. Appl.*, vol. 55, no. 4, pp. 3736–3746, Jul./Aug. 2019.
- [60] H. Hajime, T. Yoshio, and K. Keiji, "Novel sensorless control for PM synchronous motors based on maximum torque control frame," in *Proc. Eur. Conf. Power Electron. Appl.*, 2007, pp. 1–10.
- [61] H. Hida, S. Morimoto, Y. Tomigashi, and K. Ueyama, "Robust stability of the current control system to parameter errors in sensorless control based on maximum torque control frame," in *Proc. 13th Eur. Conf. Power Electron. Appl.*, 2009, pp. 1–10.
- [62] T. Inoue, Y. Inoue, S. Morimoto, and M. Sanada, "Mathematical model for MTPA control of permanent-magnet synchronous motor in stator flux linkage synchronous frame," *IEEE Trans. Ind. Appl.*, vol. 51, no. 5, pp. 3620–3628, Sep./Oct. 2015.
- [63] A. Shinohara, Y. Inoue, S. Morimoto, and M. Sanada, "Maximum torque per ampere control in stator flux linkage synchronous frame for DTC-based PMSM drives without using q-axis inductance," *IEEE Trans. Ind. Appl.*, vol. 53, no. 4, pp. 3663–3671, Jul./Aug. 2017.
- [64] P. C. Krause, R. R. Nucea, R. J. Krefuta, and O. Wasynczuk, "Analysis of a permanent magnet synchronous machine supplied from a 180° inverter with phase control," *IEEE Trans. Energy Convers.*, vol. EC-2, no. 3, pp. 423–431, Sep. 1987.
- [65] T. M. Jahns, G. B. Kliman, and T. W. Neumann, "Interior permanent-magnet synchronous motors for adjustable-speed drives," *IEEE Trans. Ind. Appl.*, vol. IA-22, no. 6, pp. 738–747, Jul. 1986.
- [66] M. Huang, K. Chen, and C. Chen, "Modeling and analysis of IPM synchronous motor under six step voltage control by Fourier series," in *Proc. 41st Annu. Conf. IEEE Ind. Electron. Soc.*, 2015, pp. 2451–2455.
- [67] R. Monajemy and R. Krishnan, "Performance comparison for six-step voltage and constant back EMF control strategies for PMSM," in *Proc. IEEE Ind. Appl. Conf. 34th IAS Annu. Meeting*, 2015, pp. 165–172.
- [68] T. Schoenen, A. Krings, D. van Treeck, and R. W. De Doncker, "Maximum DC-link voltage utilization for optimal operation of IPMSM," in *Proc. IEEE Int. Elect. Mach. Drives Conf.*, 2009, pp. 1547–1550.
- [69] T. U. Jung, S. H. Lee, S. J. Park, C. H. Yun, and Y. Tao, "BLDC motor drive system of air-condition of hybrid electric vehicle," in *Proc. Int. Conf. Elect. Mach. Syst.*, 2007, pp. 636–641.
- [70] J. Choi, J. S. Park, J. H. Kim, and I. S. Jung, "Control scheme for efficiency improvement of slim type BLDC motor," in *Proc. Int. Symp. Power Electron., Elect. Drives, Autom. Motion*, 2014, pp. 820–824.
- [71] K. Lee, S. Park, and S. Jeong, "A seamless transition control of sensorless PMSM compressor drives for improving efficiency based on a dual-mode operation," *IEEE Trans. Power Electron.*, vol. 30, no. 3, pp. 1446–1456, Mar. 2015.
- [72] R. F. Schiferl and T. A. Lipo, "Power capability of salient pole permanent magnet synchronous motors in variable speed drive applications," *IEEE Trans. Ind. Appl.*, vol. 26, no. 1, pp. 115–123, Jan./Feb. 1990.
- [73] F. Fernandez-Bernal, A. Garcia-Cerrada, and R. Faure, "Efficient control of reluctance synchronous machines," in *Proc. 24th Annu. Conf. IEEE Ind. Electron. Soc.*, 1998, pp. 923–928.
- [74] P. D. Fick and M. J. Kamper, "Accurate digital current control of the reluctance synchronous machine with constant current angle," in *Proc. IEEE 6th Africon Conf. Afr.*, 2002, pp. 685–688.
- [75] R. Al-Shehari, H. Chaoui, and H. Gualous, "MTPA trajectory tracking for IPMSM drives: A comparative study and analysis," in *Proc. IEEE Veh. Power Propul. Conf.*, 2018, pp. 1–6.
- [76] M. N. Uddin and M. M. I. Chy, "Development and implementation of a nonlinear controller incorporating flux control for IPMSM," in *Proc. 33rd Conf. IEEE Ind. Electron. Soc.*, 2007, pp. 1067–1072.
- [77] T. D. Do, S. Kwak, H. H. Choi, and J. W. Jung, "Suboptimal control scheme design for interior permanent-magnet synchronous motors: An SDRE-based approach," *IEEE Trans. Power Electron.*, vol. 29, no. 6, pp. 3020–3031, Jun. 2014.
- [78] G. Foo and M. F. Rahman, "Sensorless sliding-mode MTPA control of an IPM synchronous motor drive using a sliding-mode observer and HF signal injection," *IEEE Trans. Ind. Electron.*, vol. 57, no. 4, pp. 1270–1278, Apr. 2010.
- [79] C. B. Butt, M. A. Hoque, and M. A. Rahman, "Simplified fuzzy-logic-based MTPA speed control of IPMSM drive," *IEEE Trans. Ind. Appl.*, vol. 40, no. 6, pp. 1529–1535, Nov./Dec. 2004.
- [80] C. B. Butt and M. A. Rahman, "Untrained artificial neuron-based speed control of interior permanent-magnet motor drives over extended operating speed range," *IEEE Trans. Ind. Appl.*, vol. 49, no. 3, pp. 1146–1153, May/Jun. 2013.
- [81] H. W. de Kock, A. J. Rix, and M. J. Kamper, "Optimal torque control of synchronous machines based on finite-element analysis," *IEEE Trans. Ind. Electron.*, vol. 57, no. 1, pp. 413–419, Jan. 2010.
- [82] F. Tinazzi and M. Zigliotto, "Torque estimation in high-efficiency IPM synchronous motor drives," *IEEE Trans. Energy Convers.*, vol. 30, no. 3, pp. 983–990, Sep. 2015.
- [83] E. Armando, R. I. Bojoi, P. Guglielmi, G. Pellegrino, and M. Pastorelli, "Experimental identification of the magnetic model of synchronous machines," *IEEE Trans. Ind. Appl.*, vol. 49, no. 5, pp. 2116–2125, Sep./Oct. 2013.
- [84] L. Ortombina, F. Tinazzi, and M. Zigliotto, "Magnetic modeling of synchronous reluctance and internal permanent magnet motors using radial basis function networks," *IEEE Trans. Ind. Electron.*, vol. 65, no. 2, pp. 1140–1148, Feb. 2018.
- [85] M. Fontana and N. Bianchi, "Design and analysis of normal saliency IPM spoke motor," *IEEE Trans. Ind. Appl.*, vol. 56, no. 4, pp. 3625–3635, Jul./Aug. 2020.
- [86] A. Consoli, G. Scarcella, G. Scelba, and A. Testa, "Steady-state and transient operation of IPMSMs under maximum-torque-per-ampere control," *IEEE Trans. Ind. Appl.*, vol. 46, no. 1, pp. 121–129, Jan./Feb. 2010.
- [87] A. Consoli, G. Scelba, G. Scarcella, and M. Cacciato, "An effective energy-saving scalar control for industrial IPMSM drives," *IEEE Trans. Ind. Electron.*, vol. 60, no. 9, pp. 3658–3669, Sep. 2013.
- [88] M. Cacciato, A. Consoli, G. Scarcella, and G. Scelba, "A novel efficiency optimization scalar control technique for industrial IPMSM drives," in *Proc. IEEE Int. Symp. Ind. Electron.*, 2010, pp. 1181–1186.
- [89] J. Itoh, N. Nomura, and H. Ohsawa, "A comparison between V/f control and position-sensorless vector control for the permanent magnet synchronous motor," in *Proc. Power Convers. Conf.*, 2002, pp. 1310–1315.
- [90] J. Itoh, Y. Nakajima, and M. Kato, "Maximum torque per ampere control method for IPM synchronous motor based on V/f control," in *Proc. IEEE 10th Int. Conf. Power Electron. Drive Syst.*, 2013, pp. 1322–1327.
- [91] S. Sue, T. W. Hung, J. H. Liaw, Y. F. Li, and C. Y. Sun, "A new MTPA control strategy for sensorless V/f controlled PMSM drives," in *Proc. 6th IEEE Conf. Ind. Electron. Appl.*, 2011, pp. 1840–1844.
- [92] Z. Tang, X. Li, S. Dusmez, and B. Akin, "A new V/f-based sensorless MTPA control for IPMSM drives," *IEEE Trans. Power Electron.*, vol. 31, no. 6, pp. 4400–4415, Jun. 2016.
- [93] Y. Matsuki and S. Doki, "High stability V/f control of PMSM using state feedback control based on n-t coordinate system," in *Proc. Int. Power Electron. Conf.*, 2018, pp. 2224–2228.
- [94] P. Bertoldi, "Proceedings of the 10th international conference on energy efficiency in motor driven systems," Publications Office of the European Union, Luxembourg, 2018.
- [95] H. Kim, J. Hartwig, and R. D. Lorenz, "Using on-line parameter estimation to improve efficiency of IPM machine drives," in *Proc. IEEE 33rd Annu. IEEE Power Electron. Spec. Conf.*, 2002, vol. 2, pp. 815–820.
- [96] Y. A. R. I. Mohamed and T. K. Lee, "Adaptive self-tuning MTPA vector controller for IPMSM drive system," *IEEE Trans. Energy Convers.*, vol. 21, no. 3, pp. 636–644, Sep. 2006.

- [97] G. Schoonhoven and M. N. Uddin, "MTPA and FW-based robust nonlinear speed control of IPMSM drive using Lyapunov stability criterion," *IEEE Trans. Ind. Appl.*, vol. 52, no. 5, pp. 4365–4374, May 2016.
- [98] S. J. Underwood and I. Husain, "Online parameter estimation and adaptive control of permanent-magnet synchronous machines," *IEEE Trans. Ind. Electron.*, vol. 57, no. 7, pp. 2435–2443, Jul. 2010.
- [99] Q. Liu and K. Hameyer, "High-performance adaptive torque control for an IPMSM with real-time MTPA operation," *IEEE Trans. Energy Convers.*, vol. 32, no. 2, pp. 571–581, Jun. 2017.
- [100] L. Ortombina, F. Tinazzi, and M. Zigliotto, "Adaptive maximum torque per ampere control of synchronous reluctance motors by radial basis function networks," *IEEE Trans. Emerg. Sel. Topics Power Electron.*, vol. 7, no. 4, pp. 2531–2539, Dec. 2019.
- [101] K. Liu, Q. Zhang, J. Chen, Z. Q. Zhu, and J. Zhang, "Online multi-parameter estimation of nonsalient-pole PM synchronous machines with temperature variation tracking," *IEEE Trans. Ind. Electron.*, vol. 58, no. 5, pp. 1776–1788, May 2011.
- [102] H. W. Sim *et al.*, "On-line parameter estimation of interior permanent magnet synchronous motor using an extended Kalman filter," *J. Elect. Eng. Technol.*, vol. 9, no. 2, pp. 600–608, Mar. 2014.
- [103] Y. Zhang, K. Liu, Y. Hu, and S. Yang, "MTPA control of IPMSM with aiding from estimation of dq-axis inductances," in *Proc. IEEE Student Conf. Elect. Mach. Syst.*, 2018, pp. 1–5.
- [104] A. Accetta, M. Cirrincione, M. C. Di Piazza, G. La Tona, M. Luna, and M. Pucci, "Growing neural gas-based maximum torque per ampere (MTPA) technique for SynRMs," in *Proc. Proc. IEEE Energy Convers. Congr. Expo.*, 2020, pp. 2668–2673.
- [105] F. Lin, Y. Liu, and W. Yu, "Power perturbation based MTPA with an online tuning speed controller for an IPMSM drive system," *IEEE Trans. Ind. Electron.*, vol. 65, no. 5, pp. 3677–3687, May 2018.
- [106] G. Feng, C. Lai, K. Mukherjee, and N. C. Kar, "Current injection-based online parameter and VSI nonlinearity estimation for PMSM drives using current and voltage DC components," *IEEE Trans. Transp. Electrific.*, vol. 2, no. 2, pp. 119–128, Jun. 2016.
- [107] J. Bonifacio, N. Amann, and R. Kennel, "Online full-parameter identification strategy for IPMSM using voltage signal injection," in *Proc. 20th Eur. Conf. Power Electron. Appl.*, 2017, pp. 1–7.
- [108] Q. Liu and K. Hameyer, "A fast online full parameter estimation of a PMSM with sinusoidal signal injection," in *Proc. IEEE Energy Convers. Congr. Expo.*, 2015, pp. 4091–4096.
- [109] S. Li, D. Han, and B. Sarlioglu, "Temperature effects compensation control algorithm of IPM machines utilizing current pulse injection and online multi-parameter estimation for traction applications," in *Proc. IEEE Energy Convers. Congr. Expo.*, 2017, pp. 5461–5467.
- [110] K. Huang, J. Zhou, S. Huang, M. Shen, D. Zhang, and L. Chen, "Low-speed sensorless MTPA control of interior permanent magnet synchronous motor based on parameter self-learning," in *Proc. 22nd Int. Conf. Elect. Mach. Syst.*, 2019, pp. 1–6.
- [111] M. Krstic, "Extremum seeking control," in *Encyclopedia of Systems and Control*, J. Baillieul and T. Samad, Eds. London, U.K.: Springer, 2014.
- [112] S. Bolognani, R. Petrella, A. Prearo, and L. Sgarbossa, "On-line tracking of the MTPA trajectory in IPM motors via active power measurement," in *Proc. 19th Int. Conf. Elect. Mach.*, 2010, pp. 1–7.
- [113] N. Bedetti, S. Calligaro, C. Olsen, and R. Petrella, "Automatic MTPA tracking in IPMSM drives: Loop dynamics, design, and auto-tuning," *IEEE Trans. Ind. Appl.*, vol. 53, no. 5, pp. 4547–4558, Sep. 2017.
- [114] S. Bolognani, R. Petrella, A. Prearo, and L. Sgarbossa, "Automatic tracking of MTPA trajectory in IPM motor drives based on AC current injection," *IEEE Trans. Ind. Appl.*, vol. 47, no. 1, pp. 105–114, Jan. 2011.
- [115] R. Antonello, M. Carraro, and M. Zigliotto, "Towards the automatic tuning of MTPA algorithms for IPM motor drives," in *Proc. 20th Int. Conf. Elect. Mach.*, 2012, pp. 1121–1127.
- [116] N. Bedetti, S. Calligaro, and R. Petrella, "Self-adaptation of MTPA tracking controller for IPMSM and SynRM drives based on on-line estimation of loop gain," in *Proc. Energy Convers. Congr. Expo.*, 2017, pp. 1917–1924.
- [117] S. Bolognani, L. Sgarbossa, and M. Zordan, "Self-tuning of MTPA current vector generation scheme in IPM synchronous motor drives," in *Proc. Eur. Conf. Power Electron. Appl.*, 2007, pp. 1–10.
- [118] S. Kim, Y. D. Yoon, S. K. Sul, and K. Ide, "Maximum torque per ampere (MTPA) control of an IPM machine based on signal injection considering inductance saturation," *IEEE Trans. Power Electron.*, vol. 28, no. 1, pp. 488–497, Jan. 2013.
- [119] R. Antonello, M. Carraro, and M. Zigliotto, "Theory and implementation of a MTPA tracking controller for anisotropic PM motor drives," in *Proc. 38th Annu. Conf. IEEE Ind. Electron. Soc.*, 2012, pp. 2061–2066.
- [120] N. Bedetti, S. Calligaro, and R. Petrella, "Stand-still self-identification of flux characteristics for synchronous reluctance machines using novel saturation approximating function and multiple linear regression," *IEEE Trans. Ind. Appl.*, vol. 52, no. 4, pp. 3083–3092, Jul./Aug. 2016.
- [121] T. Sun, J. Wang, and X. Chen, "Maximum torque per ampere (MTPA) control for interior permanent magnet synchronous machine drives based on virtual signal injection," *IEEE Trans. Power Electron.*, vol. 30, no. 9, pp. 5036–5045, Sep. 2015.
- [122] T. Sun, J. Wang, and M. Koc, "Virtual signal injection-based direct flux vector control of IPMSM drives," *IEEE Trans. Ind. Electron.*, vol. 63, no. 8, pp. 4773–4782, Aug. 2016.
- [123] T. Sun, J. Wang, M. Koc, and X. Chen, "Self-learning MTPA control of interior permanent magnet synchronous machine drives based on virtual signal injection," in *Proc. IEEE Int. Elect. Mach. Drives Conf.*, 2015, pp. 1056–1062.
- [124] Q. Chen, W. Zhao, G. Liu, and Z. Lin, "Extension of virtual-signal-injection-based MTPA control for five-phase IPMSM into fault-tolerant operation," *IEEE Trans. Ind. Electron.*, vol. 66, no. 2, pp. 944–955, Feb. 2019.
- [125] T. Sun, J. Wang, and M. Koc, "On accuracy of virtual signal injection based MTPA operation of interior permanent magnet synchronous machine drives," *IEEE Trans. Power Electron.*, vol. 32, no. 9, pp. 7405–7408, Sep. 2017.
- [126] S. Calligaro, D. Marzona, A. Shahdadi, and R. Petrella, "MTPA tracking algorithms for IPMSMs and SynRMs: Accurate evaluation and adaptive tuning of real signal injection and virtual signal injection," in *Proc. Energy Convers. Congr. Expo.*, 2020, pp. 6079–6086.
- [127] T. Sun, L. Long, R. Yang, K. Li, and J. Liang, "Extended virtual signal injection control for MTPA operation of IPMSM drives with online derivative term estimation," *IEEE Trans. Power Electron.*, vol. 36, no. 9, pp. 10602–10611, Sep. 2021.
- [128] G. Wang, Z. Li, G. Zhang, Y. Yu, and D. Xu, "Quadrature PLL-based high-order sliding-mode observer for IPMSM sensorless control with online MTPA control strategy," *IEEE Trans. Energy Convers.*, vol. 28, no. 1, pp. 214–224, Mar. 2013.
- [129] H. Chaoui, O. Okoye, and M. Khayamy, "Current sensorless MTPA for IPMSM drives," *IEEE/ASME Trans. Mechatronics*, vol. 22, no. 4, pp. 1585–1593, Aug. 2017.
- [130] M. Khayamy and H. Chaoui, "Current sensorless MTPA operation of interior PMSM drives for vehicular applications," in *Proc. IEEE Ind. Appl. Conf. 34th IAS Annu. Meeting*, 1999, pp. 165–172.
- [131] F. Lin, M. Huang, S. Chen, and C. Hsu, "Intelligent maximum torque per ampere tracking control of synchronous reluctance motor using recurrent Legendre fuzzy neural network," *IEEE Trans. Power Electron.*, vol. 34, no. 12, pp. 12080–12094, Dec. 2019.
- [132] E. Daryabeigi, H. Abootorabi Zarchi, G. R. Arab Markadeh, J. Soltani, and F. Blaabjerg, "Online MTPA control approach for synchronous reluctance motor drives based on emotional controller," *IEEE Trans. Power Electron.*, vol. 30, no. 4, pp. 2157–2166, Apr. 2015.
- [133] T. Windisch and W. Hofmann, "A comparison of a signal-injection method and a discrete-search algorithm for MTPA tracking control of an IPM machine," in *Proc. 17th Eur. Conf. Power Electron. Appl.*, 2015, pp. 1–10.
- [134] K. Lee and S. B. Lee, "MTPA operating point tracking control scheme for vector controlled PMSM drives," in *Proc. Int. Symp. Power Electron., Elect. Drives, Autom. Motion*, 2010, pp. 24–28.
- [135] K. Lee and Y. Han, "MTPA control strategy based on signal injection for V/f scalar-controlled surface permanent magnet synchronous machine drives," *IEEE Access*, vol. 8, pp. 96036–96044, 2020.
- [136] Z. Han and J. Liu, "Comparative analysis of vibration and noise in IPMSM considering the effect of MTPA control algorithms for electric vehicles," *IEEE Trans. Power Electron.*, vol. 36, no. 6, pp. 6850–6862, Jun. 2021.
- [137] A. Varatharajan, G. Pellegrino, and E. Armando, "Direct flux vector control of synchronous motor drives: A small-signal model for optimal reference generation," *IEEE Trans. Power Electron.*, vol. 36, no. 9, pp. 10526–10535, Sep. 2021.
- [138] L. J. Cheng and M. C. Tsai, "Robust scalar control of synchronous reluctance motor with optimal efficiency by MTPA control," *IEEE Access*, vol. 9, pp. 32599–32612, 2021.



**Anton Dianov** (Senior Member, IEEE) received the B.Sc.(Hons.), M.Sc.(Hons.), and Ph.D.(Hons.) degrees in electrical engineering from the National Research University “Moscow Power Engineering Institute,” Moscow, Russia, in 2000, 2002, and 2005, respectively.

From 2005 to 2021, he was a Senior Engineer with Samsung Electronics, where he developed motor drives for home appliances. Since 2021, he has been a Leading Research Engineer with This Is Engineering Inc., Seongnam, South Korea, and an Associate

Professor with National Research University “Moscow Power Engineering Institute.” He is the author of more than 40 publications in the referring journals and conferences on electrical drives and motor control. He is the author of several patents on control algorithms for electrical drives and power electronics. His research interests include electrical drives, sensorless, and advanced control algorithms.

Dr. Dianov is a member of editorial board of several journals on power electronics and electrical drives, including IEEE OPEN JOURNAL OF THE INDUSTRIAL ELECTRONICS SOCIETY, *International Journal of Power Electronics*, and *Journal of Power Electronics*. He was the recipient of several personal scholarships including the scholarship from the President of Russian Federation.



**Fabio Tinazzi** (Member, IEEE) received the B.S., M.S., and Ph.D. degrees in mechatronic engineering from the University of Padova, Padua, Italy, in 2008, 2011, and 2015, respectively.

Since February 2017, he has been a Researcher with the Department of Management and Engineering, University of Padova, Vicenza, Italy. His research interests include sensorless control, predictive control, maximum efficiency control, and parameter estimation techniques for ac motors.



**Sandro Calligaro** (Member, IEEE) was born in Udine, Italy, in 1982. He received the M.S. and Ph.D. degrees in electronic engineering from the University of Udine, Udine, Italy, in 2008 and 2012, respectively.

He has been with the Polytechnic Department of Engineering and Architecture, University of Udine, as a Postdoctoral Fellow, until January 2017. He is currently with the Faculty of Science and Technology, Free University of Bozen, Bolzano, Italy. His research interests include high-performance control of permanent magnet and reluctance synchronous machines,

sensorless control, deadtime compensation, motor parameters identification, multilevel inverter modulation strategies, and modeling and control of power converters.



**Silverio Bolognani** (Fellow, IEEE) received the Laurea degree in electrical engineering from the University of Padova, Padua, Italy, in 1976.

In 1976, he joined the Department of Electrical Engineering, University of Padova, where he was involved in the analysis and design of thyristor converters and synchronous motor drives. Successively, he has carried out research activities about the design and control of motor drives for land and marine propulsion, energy generation and conversion, home appliances, automotive, and industry. He is the Principal

Investigator of research contracts with industries, and also research projects funded by National and European Institutions. He is the author of more than 300 international publications on electric machines and drives (Scopus H-index 51). He has given seminars and invited presentations in international conferences and foreign universities. His teaching activity at the University of Padova dealt with courses of electromagnetic fields and electrical circuit theory and, later, with electric traction, electric drives, design of electric machines, and industrial electrical applications.

Mr. Bolognani is the Chairman of the IEEE IA/IE/PEL North Italy Joint Chapter, a member of the Scientific Committee of national and international conferences and associations, Reviewer of international scientific journals, and Evaluator of research projects in national and international programs. He was the Head of the Department of Electrical Engineering from 2001 to 2008, a member of the Scientific Committee of the University of Padova from 2004 to 2008, and the Vice-Rector for the Research from 2009 to 2015.