





# Letters

## ZVZCS Full-Bridge Three-Level DC/DC Converter With Reduced Device Count

Dong Liu , Senior Member, IEEE, Yanbo Wang , Senior Member, IEEE, Qi Zhang , Student Member, IEEE, and Zhe Chen , Fellow, IEEE

**Abstract**—This letter proposes a new zero-voltage and zero-current switching (ZVZCS) full-bridge (FB) three-level dc/dc converter (TLDC) with the reduced device count. The merits of the proposed converter with the corresponding modulation strategy are concluded as follows. In comparison with the zero-voltage-switching FB TLDC: 1) only one blocking capacitor is added to realize the ZVZCS strategy, 2) the primary circulating current and duty cycle loss can be effectively reduced. Also, the wide input voltage range can be satisfied because of having two working patterns. More significantly, the proposed converter with the corresponding modulation strategy can reduce the device count by removing the primary blocking diodes in comparison with other ZVZCS FB TLDCs, which would reduce the conduction losses of primary power devices and thus increase the converter's efficiency. Finally, experimental results are presented to verify the proposed converter with the corresponding modulation strategy.

**Index Terms**—Full-bridge (FB), reduced device count (RDC), three-level dc/dc converter (TLDC), wide input voltage range, zero-voltage and zero-current switching (ZVZCS).

### I. INTRODUCTION

THE three-level (TL) dc/dc converter (TLDC) is one of the most attractive candidates for the high voltage applications because the voltage stress on the primary power switches is only half of the input voltage ( $V_{in}/2$ ) in the TLDC [1]–[3]. So far, many studies about the TLDC have been carried out. A novel four-switch TLDC with a compact circuit structure was proposed in [4]. Based on [4], new input-parallel output-parallel TLDCs with minimized and balanced currents on input capacitors were proposed in [5] and several new TLDCs were proposed in [6] with the major merits of extended zero-voltage-switching (ZVS) range and compact circuit structure for the industrial applications. Besides, the full-bridge (FB) TLDC with a

balanced power device current-based modulation strategy was proposed in [7].

The TLDCs mentioned above can all obtain ZVS, but they have some drawbacks including high duty cycle loss, high circulating current, and limited soft switching range. To solve these problems, some new TLDCs with zero-voltage and zero-current switching (ZVZCS) were proposed [8]–[13]. In [8], a ZVZCS half-bridge (HB) TLDC with a secondary active clamp circuit and a simple phase-shift control was proposed. Several ZVZCS TLDCs with simple circuit structures by removing clamping diodes were proposed in [6], in which a phase-shift control is applied to these proposed ZVZCS TLDCs. In addition, G. Ning, *et al.* [9] proposed a hybrid ZVZCS HB TLDC with two transformers and the resonant tank, in which the duty ratio control is used to adjust the output voltage. A new ZVZCS HB TLDC with a wide soft switching range and a compact structure was proposed in [10]. However, the HB converter is normally not suitable for higher power applications because of the high current stress on the primary power devices in comparison with the FB converter. A ZVZCS dual bridge TLDC with phase-shift control was proposed in [11], in which two four-switch ZVZCS HB TLDCs are connected in parallel. Besides, a hybrid ZVZCS FB TLDC with duty ratio control and a ZVZCS FB TLDC with phase-shift control were proposed in [12] and [13], respectively, for high power applications. Unfortunately, these ZVZCS FB TLDCs all need to add the blocking diodes for resetting the primary current and realizing zero-current-switching (ZCS), which would thus cause extra power losses. Consequently, it is still a valuable work to design a ZVZCS FB TLDC with a lower device count and higher efficiency.

In this letter, a new ZVZCS FB TLDC with the corresponding modulation strategy is proposed, which maintains the merits of the ZVZCS TLDC that reducing the primary circulating current and duty cycle loss. More significantly, compared with other ZVZCS FB TLDCs, the proposed converter can not only satisfy the wide input voltage range but also reduce conduction losses of the primary power devices due to the reduced device count (RDC) by removing the blocking diodes. The circuit structure, operation principles, and performances of the proposed converter are discussed. Finally, experimental results are presented to verify the proposed converter with the corresponding

Manuscript received January 8, 2020; revised February 8, 2020; accepted February 23, 2020. Date of publication February 28, 2020; date of current version June 23, 2020. This work was supported by the ForsKEL and EUDP Project “Voltage control and protection for a grid towards 100% power electronics and cable network (COPE) under Project 64017-0047.” (Corresponding author: Dong Liu.)

The authors are with the Department of Energy Technology, Aalborg University, Aalborg 9220, Denmark (e-mail: dli@et.aau.dk; ywa@et.aau.dk; qzg@et.aau.dk; zch@et.aau.dk).

Color versions of one or more of the figures in this article are available online at <http://ieeexplore.ieee.org>.

Digital Object Identifier 10.1109/TPEL.2020.2977227

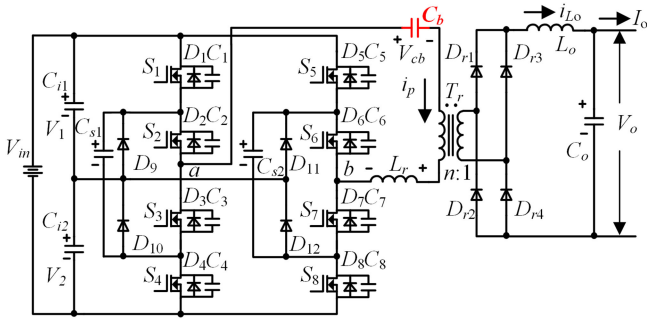

Fig. 1. Circuit structure of proposed converter.

modulation strategy. The proposed converter can be applied to many industrial applications with the high input voltage, such as step-down stage dc/dc converter after 3 phase power factor correction and dc interfaces for microgrids.

## II. CIRCUIT STRUCTURE AND OPERATION PRINCIPLE

Fig. 1 shows the circuit structure of the proposed converter. It needs to be mentioned that: in comparison with the conventional ZVS FB TLDC in [7], the proposed converter adds one more blocking capacitor  $C_b$  as marked in Fig. 1 and thus have a little more complex circuit structure. However, the proposed converter belongs to the ZVZCS converter, which means that it can solve the drawbacks of the conventional ZVS converter including the high duty cycle loss and high circulating current.

In Fig. 1,  $C_{i1}$  and  $C_{i2}$  are two input capacitors which split the input voltage  $V_{in}$  into two voltages ( $V_1$  and  $V_2$ );  $S_1$ – $S_8$  are primary power switches;  $D_1$ – $D_8$  are body diodes of  $S_1$ – $S_8$ ;  $C_1$ – $C_8$  are parasitic capacitors of  $S_1$ – $S_8$ ;  $C_{s1}$  and  $C_{s2}$  are two flying capacitors;  $D_9$ – $D_{12}$  are four clamping diodes;  $T_r$  is the isolation transformer;  $L_r$  is the leakage inductance of  $T_r$ ;  $n$  is the turns ratio of  $T_r$ ;  $D_{r1}$ – $D_{r4}$  are output rectifier diodes;  $L_o$  and  $C_o$  are output filter inductor and capacitor, respectively. In addition,  $V_{in}$  is the input voltage;  $V_{ab}$  is the voltage between point  $a$  and  $b$ ;  $i_p$  is the primary current of  $T_r$ ;  $V_{cb}$  is the voltage on  $C_b$ ;  $i_{L_o}$  is the current on  $L_o$ ;  $V_o$  and  $I_o$  are the output voltage and current.

To simplify the following analysis, several assumptions are made as: 1) all power switches and diodes are ideal; 2)  $C_{i1}$ ,  $C_{i2}$ , and  $C_{s1}$ ,  $C_{s2}$  are large enough to be considered as the voltage sources with  $V_{in}/2$ ; and 3)  $L_o$  is large enough to be considered as a constant current source.

Fig. 2 shows the proposed modulation strategy with converter's key waveforms, in which  $d_{rv1}$ – $d_{rv8}$  are the driving signals of  $S_1$ – $S_8$ ;  $d$  is the duty ratio in one switching period  $T_s$ ;  $\alpha$  is the phase-shift time. The proposed modulation strategy is composed of two working patterns, which can thus satisfy the wide input voltage range.

1) *Working pattern I* is used for the low input voltage. In the working pattern I,  $\alpha$  is kept at a constant value. By adjusting the value of the duty ratio  $d$ , the time length of the third-level voltages ( $V_{in}$  and  $-V_{in}$ ) as marked by the red color in Fig. 2(a) can be changed, which would thus change the output voltage  $V_o$ . In practical applications, the duty cycle 0.5 minus the dead time divided by  $T_s$  is set for driving signals of power switches  $S_2$ ,

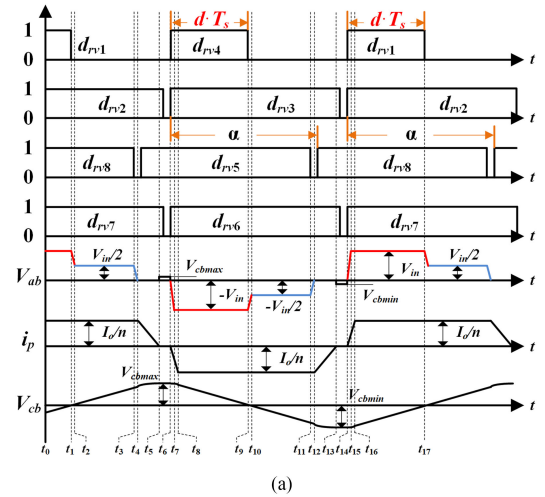

(a)

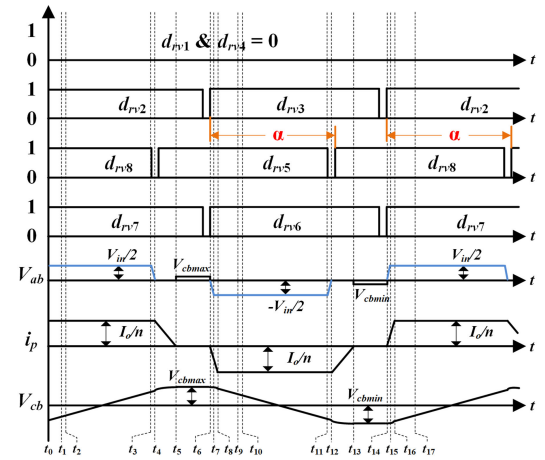

(b)

Fig. 2. Proposed corresponding modulation strategy. (a) Working pattern I. (b) Working pattern II.

$S_3$ ,  $S_5$ ,  $S_6$ ,  $S_7$ , and  $S_8$ ; the duty ratio  $d$  would be obtained by the calculation from the control loop and is set for driving signals of power switches  $S_1$  and  $S_4$ .

2) *Working pattern II* is used for the high input voltage after the duty ratio  $d$  reduces to zero with the increasing of the input voltage. By adjusting the value of the phase-shift time  $\alpha$ , the time length of the second-level voltages ( $V_{in}/2$  and  $-V_{in}/2$ ) as marked by the blue color in Fig. 2(b) can be changed, which would thus change the output voltage  $V_o$ . In practical applications, the duty ratio of  $d_{rv1}$  and  $d_{rv4}$  are set at zero; the duty cycle 0.5 minus the dead time divided by  $T_s$  is set for driving signals of power switches  $S_2$ ,  $S_3$ ,  $S_5$ ,  $S_6$ ,  $S_7$ , and  $S_8$ ; the phase-shift time  $\alpha$  would be obtained by the calculation from the control loop.

Fig. 3 presents equivalent circuits during the time period  $[t_0$ – $t_9]$  in the working pattern I shown in Fig. 2(a).

*Stage I*  $[t_0$ – $t_1]$ : During this stage,  $S_1$ ,  $S_2$ ,  $S_7$ , and  $S_8$  are all in ON-state, so  $V_{ab}$  equals to  $V_{in}$  and the input power transfers to the load through  $D_{r1}$  and  $D_{r4}$ . The primary current  $i_p$  is  $I_o/n$  and  $V_{cb}$  increases with the change rate given as (1)

$$\frac{dV_{cb}}{dt} = \frac{I_o}{n \cdot C_b}. \quad (1)$$

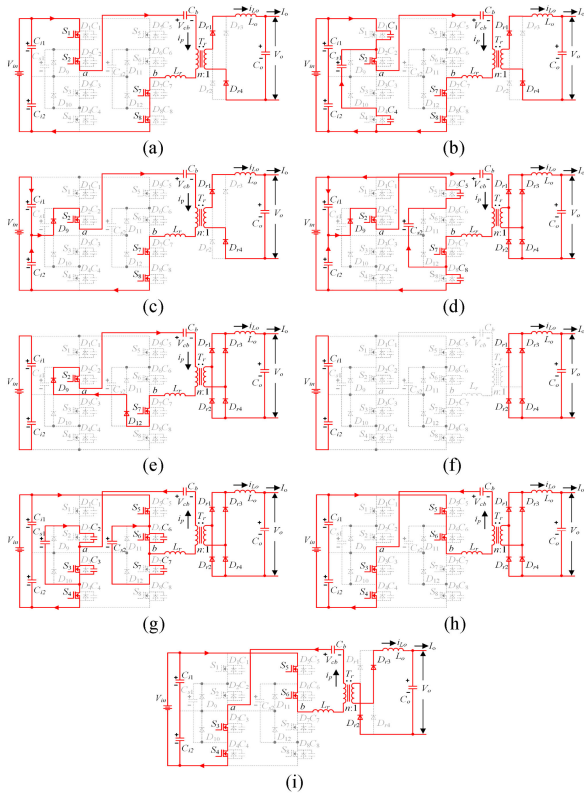

Fig. 3. Equivalent circuits in working pattern I. (a)  $[t_0-t_1]$ . (b)  $[t_1-t_2]$ . (c)  $[t_2-t_3]$ . (d)  $[t_3-t_4]$ . (e)  $[t_4-t_5]$ . (f)  $[t_5-t_6]$ . (g)  $[t_6-t_7]$ . (h)  $[t_7-t_8]$ . (i)  $[t_8-t_9]$ .

**Stage 2**  $[t_1-t_2]$ : At  $t_1$ ,  $S_1$  is turned OFF,  $C_1$  and  $C_4$  start to be charged and discharged, respectively.

**Stage 3**  $[t_2-t_3]$ : At  $t_2$ , the voltage on  $C_4$  decreases to 0 V and the voltage on  $C_1$  increases to  $V_{in}/2$ . Therefore,  $D_9$  conducts, which clamps the voltage on  $C_4$  at 0 V. During this stage,  $V_{ab}$  is equal to  $V_{in}/2$  and  $i_p$  remains  $I_o/n$ .

**Stage 4**  $[t_3-t_4]$ : At  $t_3$ ,  $S_8$  is turned OFF.  $C_5$  and  $C_8$  start to be discharged and charged.  $i_p$  is not enough to provide the output current  $I_o$  and starts to decrease. Accordingly,  $D_{r1}$ ,  $D_{r2}$ ,  $D_{r3}$ , and  $D_{r4}$  would conduct simultaneously, which clamps both the primary and secondary voltage of the transformer at 0 V.

**Stage 5**  $[t_4-t_5]$ : At  $t_4$ , the voltage on  $C_5$  decreases to 0 V and the voltage on  $C_8$  increases to  $V_{in}/2$ . Therefore,  $D_{12}$  conducts and clamps the voltage on  $C_5$  at 0 V, which means  $S_5$  can be turned ON with ZVS. During this stage, the voltage on  $L_r$  is  $-V_{cb}$ , so  $i_p$  decreases with the change rate given as (2). The time period  $[t_4-t_5]$  can be obtained by (3) approximately

$$\frac{di_p}{dt} = -\frac{V_{cb}}{L_r} \quad (2)$$

$$t_5 - t_4 \approx \frac{L_r \cdot I_o}{n \cdot V_{cb\_max}}. \quad (3)$$

**Stage 6**  $[t_5-t_6]$ : At  $t_5$ , the primary current  $i_p$  decreases to 0 A. Therefore,  $S_2$  and  $S_7$  can be turned OFF with ZCS during this stage.

**Stage 7**  $[t_6-t_7]$ : At  $t_6$ ,  $S_3$ ,  $S_4$ ,  $S_6$  are all turned ON.  $S_4$  can be turned ON with ZVS. Then,  $C_3$ ,  $C_6$  are discharged and  $C_2$ ,  $C_7$  are charged. The primary current  $i_p$  starts to decrease.

**Stage 8**  $[t_7-t_8]$ : At  $t_7$ , the voltage of  $C_3$ ,  $C_6$  decrease to 0 V and the voltage of  $C_2$ ,  $C_7$  increase to  $V_{in}/2$ . During this stage, the primary current  $i_p$  decreases rapidly with the change rate given as (4)

$$\frac{di_p}{dt} = -\left(\frac{V_{in} + V_{cb}}{L_r}\right). \quad (4)$$

**Stage 9**  $[t_8-t_9]$ : At  $t_8$ , the primary current  $i_p$  decreases to the negative reflected output current  $-I_o/n$ . Then,  $D_{r1}$ ,  $D_{r4}$  become OFF-state, the input power is transferred to the load through  $D_{r2}$ ,  $D_{r3}$ .

At  $t_9$ ,  $S_4$  is turned OFF. The second half cycle  $[t_9-t_{17}]$  starts. The analysis during  $[t_9-t_{17}]$  is similar to that during  $[t_1-t_9]$ , which is not repeated here. The equivalent circuits and related analysis of the working pattern II are similar to that in the working pattern I as above, which are not repeated here.

### III. BRIEF DISCUSSION

#### A. Selection of Blocking Capacitor

The selection of the blocking capacitor is mainly decided by the primary current reset time and the leakage inductance of the transformer. According to the required maximum reset time named  $T_{reset\_max}$ , the needed capacitance of the blocking capacitor can be approximately obtained by (5) if the energy stored in the blocking capacitor is much higher than the energy stored in the leakage inductance

$$C_b < \frac{\alpha \cdot T_{reset\_max}}{2 \cdot L_r}. \quad (5)$$

From (5), it can be also observed that the reset time is positively proportional to the transformer's leakage inductance and the blocking capacitor's capacitance. However, it needs to be mentioned that the voltage stress on the blocking capacitor is negatively proportional to the blocking capacitor's capacitance.

#### B. Soft Switching Performances

For the inner power switches  $S_2$ ,  $S_3$ ,  $S_6$ ,  $S_7$ : 1)  $S_2$ ,  $S_3$ ,  $S_6$ ,  $S_7$  can be turned OFF after  $i_p$  is reset to 0 A. Therefore, with the proper design,  $S_2$ ,  $S_3$ ,  $S_6$ ,  $S_7$  can realize ZCS turn-OFF in a wide load range. 2) When  $S_2$ ,  $S_3$ ,  $S_6$ , and  $S_7$  are turned ON, the leakage inductance of the transformer  $L_r$  limits the change rate of  $i_p$  from 0 A, which would thus reduce the turn-ON losses. However, the energy stored in the parasitic capacitors of  $S_2$ ,  $S_3$ ,  $S_6$ ,  $S_7$  would lose at the turn-ON.

For the outer power switches  $S_1$ ,  $S_4$ ,  $S_5$ ,  $S_8$ : 1) The maximum voltage on  $S_1$ ,  $S_4$  at the turn-ON are  $2 \cdot V_{cb}$  and  $V_{cb}$  is relatively small in comparison with  $V_{in}/2$ , so the switch-ON loss of  $S_1$ ,  $S_4$  would be small and it can be said that  $S_1$ ,  $S_4$  can realize the virtual ZVS turn-ON in a wide load range. 2)  $S_5$ ,  $S_8$  can also realize the ZVS turn-ON. Although  $S_5$ ,  $S_8$  would lose the ZVS turn-ON at the light load, only the energy stored in the parasitic capacitors of  $S_5$  and  $S_8$  would lose at the turn-ON because the primary current  $i_p$  is reset to 0 A. 3)  $S_1$ ,  $S_4$ ,  $S_5$ ,  $S_8$  are turned OFF at the hard switching.

Table I presents a theoretical comparison of the ZVS range between other ZVZCS FB TLDCs and the proposed converter.

TABLE I  
COMPARISON OF ZVS RANGE

Item	Hybrid ZVZCS FB TLDC [12]	Conventional ZVZCS FB TLDC [13]	Proposed converter
ZVS Range	$I_0 \geq n \cdot V_{in} \cdot \sqrt{\frac{C_j}{2 \cdot L_f}}$	$n \cdot V_{in} \cdot \sqrt{\frac{C_j}{L_f}}$	$n \cdot V_{in} \cdot \sqrt{\frac{C_j}{2 \cdot L_f}}$

Note:  $C_j$  is the capacitance of the parasitic capacitors of low-voltage power switches.

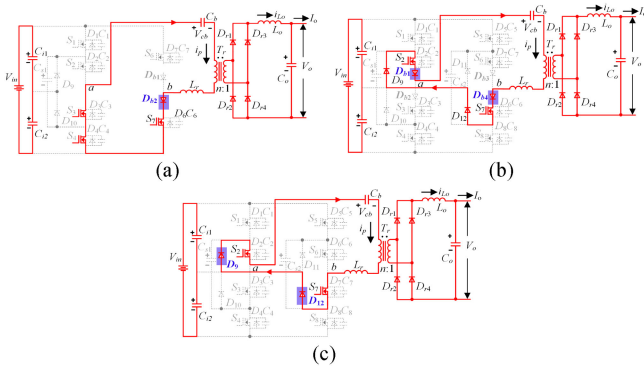

Fig. 4. Equivalent circuits during  $i_p$  reset. (a) Hybrid ZVZCS FB TLDC. (b) Conventional ZVZCS FB TLDC. (c) Proposed ZVZCS FB TLDC.

### C. Comparison With Other ZVZCS TLDCs

1) *Comparison of Device Counts of Main Primary Power Devices:* Table II presents comparison results about device counts of the main primary power devices between other ZVZCS TLDCs and the proposed converter. From Table II, the following points can be observed. 1) Although the hybrid ZVZCS FB TLDC has the lowest device count of main primary power devices, it needs two power switches with high voltage stress ( $V_{in}$ ) as marked in Table II. The primary power switches in the conventional ZVZCS FB TLDC and proposed converter only needs to withstand half of the input voltage ( $V_{in}/2$ ). 2) More importantly, by removing the blocking diodes, the proposed converter reduces the device count of primary power devices as marked in Table II and thus has a more compact circuit structure.

2) *Comparison of Conduction Power Losses of Primary Power Devices:* Fig. 4 presents the equivalent circuits when resetting the primary current to 0 A in the positive side.

From Fig. 4, the following points can be observed. 1) In other ZVZCS FB TLDCs as highlighted in Fig. 4(a) and (b), the blocking diodes in series with the primary main power switches need to be added to reset the primary current, which would cause extra conduction losses because the primary current  $i_p$  would also go through these blocking diodes. However, 2) there is no need to add blocking diodes in the proposed converter with the corresponding modulation strategy because the clamping diodes can be also used as the blocking diodes as highlighted in Fig. 4(c). Therefore, the proposed converter can effectively reduce the conduction losses due to RDC and thus increase

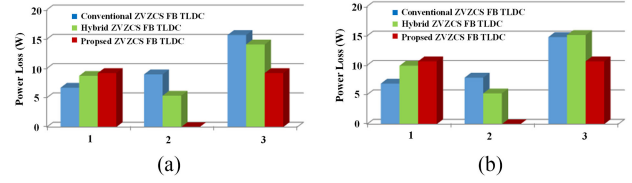

Fig. 5. Comparison results of calculated conduction losses of main primary power devices ( $V_o = 50$  V,  $P_o = 1$  kW). (a)  $V_{in} = 300$  V. (b)  $V_{in} = 450$  V. Note: 1) Conduction losses of primary power switches and clamping diodes. 2) Conduction losses of blocking diodes. 3) Total conduction losses of main primary power devices (1) + 2).

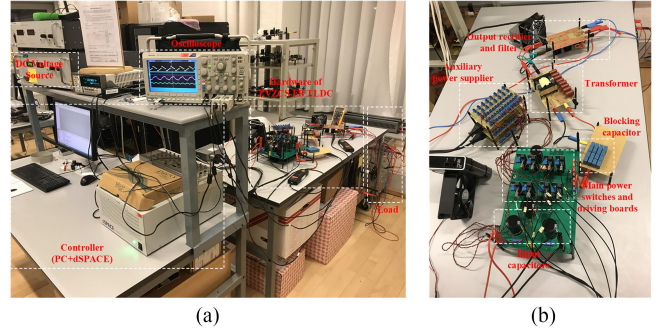

Fig. 6. (a) Experimental setup. (b) Hardware of proposed converter.

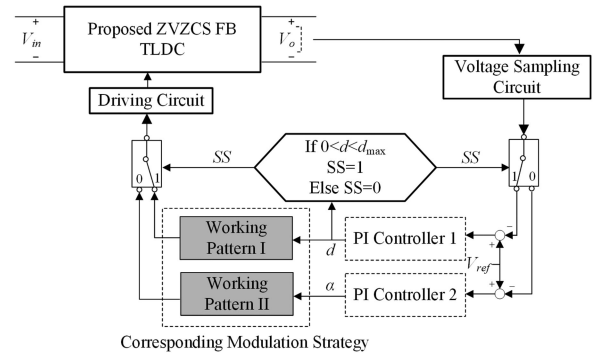

Fig. 7. Diagram about implementation of proposed modulation strategy.

the converter's efficiency in comparison with other ZVZCS FB TLDCs.

Fig. 5 presents comparison results about calculated conduction losses of the main primary power devices based on the circuit parameters listed in Table II.

## IV. EXPERIMENTAL VERIFICATION

A 1 kW prototype of the proposed converter is established, whose circuit parameters are listed in Table III. Fig. 6 presents the photograph of the experimental setup and hardware of the proposed converter.

Fig. 7 presents the diagram about the implementation of the proposed modulation strategy, in which the conventional proportional-integral control algorithm is utilized to calculate the duty ratio  $d$  and phase-shift time  $\alpha$ . As shown in Fig. 7, the working pattern I is used for the low input voltage by adjusting the duty ratio  $d$  from maximum value  $d_{max}$  to 0;

TABLE II  
 COMPARISON RESULTS OF DEVICE COUNTS

Main primary power devices	Half-bridge Structure			Full-bridge Structure				
	Hybrid Resonant ZVZCS [9]	TLDC	HB ZVZCS TLDC [10]	ZVZCS Bridge [11]	Dual TLDC	Hybrid ZVZCS FB TLDC [12]	Conventional ZVZCS FB TLDC [13]	Proposed Converter
Power switch	$V_{in}$	0	0	0	2	2	0	0
	$V_{in}/2$	4	4	8	4	4	8	8
Blocking diode or switch		2	2	4	2	2	4	0
Clamping diode		2	0	0	2	2	4	4
Blocking capacitor		1	1	2	1	1	1	1
Flying capacitor		1	0	0	1	1	2	2
Transformer		2	1	2	1	1	1	1
Total device count		12	8	16	13	20	16	16

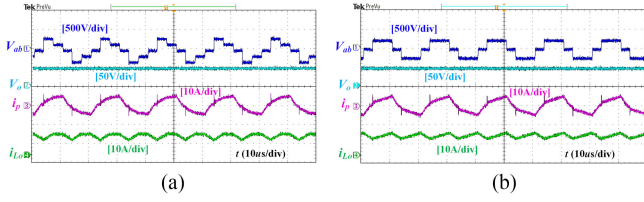
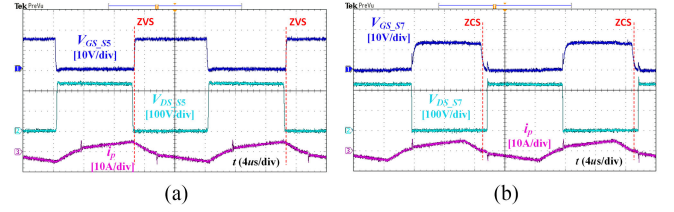
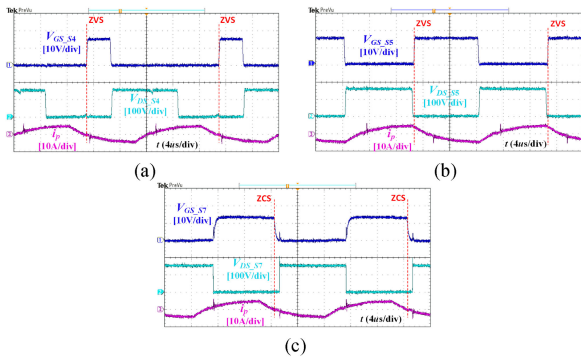
 Fig. 8. Experimental results including  $V_{ab}$ ,  $V_o$ ,  $i_p$ , and  $i_{Lo}$  ( $V_o = 50$  V,  $P_o = 500$  W). (a) Working pattern I ( $V_{in} = 300$  V). (b) Working pattern II ( $V_{in} = 450$  V).

 Fig. 10. Soft switching performances in working pattern II ( $V_{in} = 450$  V,  $V_o = 50$  V,  $P_o = 500$  W). (a)  $S_5$ . (b)  $S_7$ .

 Fig. 9. Soft switching performances in working pattern I ( $V_{in} = 300$  V,  $V_o = 50$  V,  $P_o = 500$  W). (a)  $S_4$ . (b)  $S_5$ . (c)  $S_7$ .

when  $d$  decreases to 0 due to the increase of the input voltage, the working pattern II would be used for the higher input voltage by adjusting the phase-shift time  $\alpha$ .

Fig. 8 presents the experimental results including  $V_{ab}$ ,  $V_o$ ,  $i_p$ , and  $i_{Lo}$ .

From Fig. 8, it can be observed that the primary current  $i_p$  can be reset to zero with no blocking diode in both two working patterns, which would thus reduce the primary circulating current and power losses.

Figs. 9 and 10 present soft switching performances in the working pattern I and II, respectively. In Figs. 9 and 10,  $V_{GS\_S4}$ ,  $V_{GS\_S5}$ , and  $V_{GS\_S7}$  are driving signals of  $S_4$ ,  $S_5$ , and  $S_7$ ;  $V_{DS\_S4}$ ,  $V_{DS\_S5}$ , and  $V_{DS\_S7}$  are drain-source voltages of  $S_4$ ,  $S_5$ , and  $S_7$ . From Figs. 9 and 10, it can be observed that: 1)  $S_4$  can realize the virtual ZVS turn-ON; 2)  $S_5$  can realize the ZVS turn-ON; 3)  $S_7$  can realize the ZCS turn-OFF.

Fig. 11 presents the experimental results about transition performances of the proposed converter, which includes the

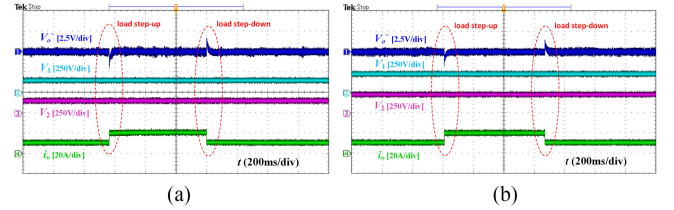
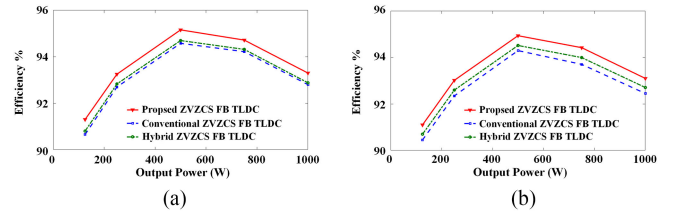
 Fig. 11. Experimental results about transition performances of proposed converter. (a)  $V_{in} = 300$  V. (b)  $V_{in} = 450$  V.

 Fig. 12. Efficiency results ( $V_o = 50$  V). (a)  $V_{in} = 300$  V. (b)  $V_{in} = 450$  V.

input voltage ( $V_{in}$ ), voltages on the two input capacitors ( $V_1$ ,  $V_2$ ), and ac component of the output voltage  $V_o \sim$ .

In Fig. 11, the output power steps up from 500 W to 1 kW and is finally set back to 500 W when the output voltage  $V_o$  is 50 V. From Fig. 11, it can be observed that: 1) the voltages among the two input capacitors are balanced and 2) there is no abnormal voltage spike on the two input capacitors during the transitions.

Fig. 12 presents comparison results about efficiency curves among ZVZCS FB TLDCs. The related circuits parameters are listed in Table II. From Fig. 12, it can be concluded that the proposed converter with the corresponding strategy can effectively increase the efficiencies due to removing the blocking diodes in comparison with other ZVZCS FB TLDCs.

It needs to be mentioned that: 1) in order to further improve the efficiency of the proposed converter, the output rectifier diodes can be replaced by Si or even GaN power switches for the synchronous rectification when the input voltage is much higher than the output voltage and the input current is much lower than the output current; 2) SiC Schottky diode with higher rating voltage can be used when the input voltage is high.

## V. CONCLUSION

In this letter, a new ZVZCS FB TLDC with the RDC is proposed. The merits of the proposed converter with the corresponding modulation strategy include: 1) realizing the ZVZCS for the power switches; 2) reducing the primary circulating current and duty cycle loss in comparison with conventional ZVS FB TLDCs; 3) satisfying the wide input voltage range because of having two working patterns; and 4) having a more compact circuit structure by removing the primary blocking diodes, which would reduce conduction losses of the primary power devices and increase the converter's efficiency, in comparison with other ZVZCS FB TLDCs. Finally, the proposed converter with the corresponding modulation strategy is verified by the experimental results. It needs to be mentioned that the main disadvantages of the proposed converter are: 1) high voltage stress on the output rectifier diodes; and 2) hard switching-ON for the power switches  $S_2$ ,  $S_3$ ,  $S_6$ , and  $S_7$ .

## APPENDIX

TABLE III  
MAIN CIRCUIT PARAMETERS

Item	Hybrid ZVZCS FB TLDC [12]	ZVZCS FB TLDC [13]	Proposed converter
Power switches (voltage stress)	$V_{in}$ IPW90R120C3	/	/
	$V_{in}/2$	IPW65R045C7	
Blocking diodes	IDP30E60		/
Clamping diodes	IDP30E60		
Blocking capacitor ( $\mu\text{F}$ )		1	
Turns ratios of $T_r$		25/8	
Output rectifier diodes		FFA40UP35S	

## REFERENCES

- [1] J. R. Pinheiro and I. Barbi, "The three-level ZVS-PWM DC-to-DC converter," *IEEE Trans. Power Electron.*, vol. 8, no. 4, pp. 486–492, Oct. 1993.
- [2] W. Li, S. Zong, F. Liu, H. Yang, X. He, and B. Wu, "Secondary-side phase-shift-controlled ZVS DC/DC converter with wide voltage gain for high input voltage applications," *IEEE Trans. Power Electron.*, vol. 28, no. 11, pp. 5128–5139, Nov. 2013.
- [3] Z. Guo, K. Sun, and D. Sha, "Improved ZVS three-level dc-dc converter with reduced circulating loss," *IEEE Trans. Power Electron.*, vol. 31, no. 9, pp. 6394–6404, Sep. 2016.
- [4] I. Barbi, R. Gules, R. Redl, and N. O. Sokal, "DC/DC converter: Four switches  $V_{pk} = V_{in}/2$ , capacitive turn-off snubbing, ZV turn-on," *IEEE Trans. Power Electron.*, vol. 19, no. 4, pp. 918–927, Jul. 2004.
- [5] D. Liu, F. Deng, Z. Gong, and Z. Chen, "Input-parallel output-parallel three-level dc/dc converters with interleaving control strategy for minimizing and balancing capacitor ripple currents," *IEEE J. Emerg. Sel. Top. Power Electron.*, vol. 5, no. 3, pp. 1122–1132, Sep. 2017.
- [6] Y. Shi and X. Yang, "Wide range soft switching PWM three-level DC-DC converters suitable for industrial applications," *IEEE Trans. Power Electron.*, vol. 29, no. 2, pp. 603–616, Feb. 2014.
- [7] D. Liu, Y. Wang, F. Deng, and Z. Chen, "Balanced power device currents based modulation strategy for full-bridge three-level DC/DC converter," *IEEE Trans. Power Electron.*, vol. 35, no. 2, pp. 2008–2022, Feb. 2020.
- [8] F. Canales, P. Barbosa, and F. C. Lee, "A zero-voltage and zero-current switching three-level DC/DC converter," *IEEE Trans. Power Electron.*, vol. 17, no. 6, pp. 898–904, Nov. 2002.
- [9] G. Ning *et al.*, "A hybrid resonant ZVZCS three-level converter for MVDC-connected offshore wind power collection systems," *IEEE Trans. Power Electron.*, vol. 33, no. 8, pp. 6633–6645, Aug. 2018.
- [10] Y. Shi, X. Wang, J. Xi, X. Gui, and X. Yang, "Wide load range ZVZCS three-level DC-DC converter with compact structure," *IEEE Trans. Power Electron.*, vol. 34, no. 6, pp. 5032–5037, Jun. 2019.
- [11] Y. Shi, "Soft switching PWM full bridge three-level DC-DC converters," in *Proc. IEEE Int. Power Electron. Appl. Conf. Expo.*, 2018.
- [12] X. Ruan and B. Li, "Zero-voltage and zero-current-switching PWM hybrid full-bridge three-level converter," *IEEE Trans. Ind. Electron.*, vol. 52, no. 1, pp. 213–220, Feb. 2005.
- [13] J. A. Carr, B. Rowden, and J. C. Balda, "A three-level full-bridge zero-voltage zero-current switching converter with a simplified switching Scheme," *IEEE Trans. Power Electron.*, vol. 24, no. 2, pp. 329–338, Feb. 2009.