

Letters

Mitigation of Interharmonics in PV Systems With Maximum Power Point Tracking Modification

Ariya Sangwongwanich [✉], Member, IEEE, and Frede Blaabjerg [✉], Fellow, IEEE

Abstract—Interharmonics are emerging power quality challenges in grid-connected photovoltaic (PV) systems. Previous studies and field measurements have confirmed the evidence of interharmonic emission from PV inverters, where the maximum power point tracking (MPPT) is one of the main causes for interharmonics. In that regard, the MPPT parameters such as their sampling rate has a strong impact on the interharmonic characteristic of the PV system. In general, there is a trade-off between the interharmonic emission and the MPPT performance when selecting the sampling rate of the MPPT algorithm. More specifically, employing a faster MPPT sampling rate will improve the MPPT efficiency, but it will also increase the interharmonic emission level. To solve this issue, a new mitigating solution for interharmonics in PV systems is proposed in this paper. The proposed method modifies the MPPT algorithm in a way to randomly select the sampling rate between the fast and the slow value. By doing so, the interharmonics in the output current can be effectively reduced due to the distribution of the frequency spectrum. On the other hand, the MPPT performance of the proposed method can be maintained similar to the case when employing a fast MPPT sampling rate. The effectiveness of the proposed interharmonic mitigation has been validated experimentally on a single-phase grid-connected PV system.

Index Terms—Interharmonics, inverters, maximum power point tracking (MPPT), photovoltaic (PV) systems, power quality.

I. INTRODUCTION

WITH an increasing penetration level of photovoltaic (PV) systems, challenging issues related to the grid integration have been arisen in the last decade. One of the emerging power quality problems for grid-connected PV systems is the interharmonics, which are defined as the frequency components that are non-integer times of the fundamental frequency [1]. Recent studies have reported that PV inverters are the potential source of interharmonic emission for PV systems, which have been observed both in the laboratory testing environment and the field measurements [2]–[6]. Although the interharmonics standard regarding the emission limit is still under development, the interharmonics can cause grid voltage fluctuations, flickering, and unintentionally disconnection of PV systems. Thus, the interharmonics emission in PV systems should be avoided and mitigations are needed [7].

According to the previous studies [3]–[6], the maximum power point tracking (MPPT) operation is one of the main causes for interharmonics

Manuscript received January 11, 2019; revised February 12, 2019; accepted February 22, 2019. Date of publication March 4, 2019; date of current version June 10, 2019. This work was supported by the Reliable Power Electronic-Based Power System (REPEPS) project at the Department of Energy Technology, Aalborg University as a part of the Villum Investigator Program funded by the Villum Foundation. Recommended for publication by Associate Editor K. Kim. (Corresponding author: Ariya Sangwongwanich.)

The authors are with the Department of Energy Technology, Aalborg University, Aalborg DK-9220, Denmark (e-mail:

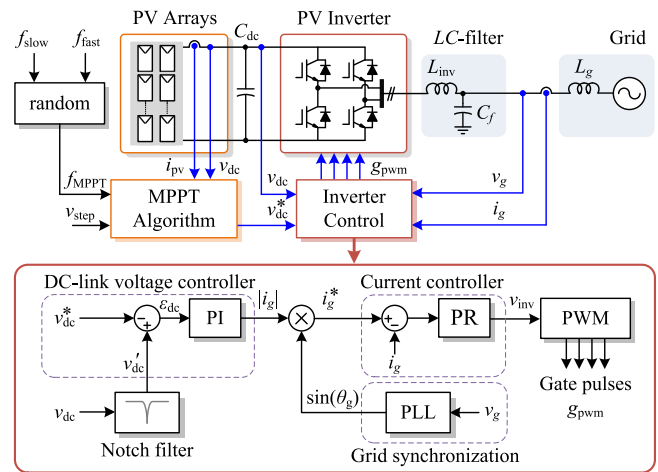

Fig. 1. System diagram and control structure of single-stage single-phase PV inverter (PI: proportional integral, PR: proportional resonant, PWM: pulswidth modulation, PLL: phase-locked loop).

in PV systems. In particularly, the perturbation of the PV arrays voltage during the maximum power point (MPP) searching inevitably induces power oscillations at the dc side, especially during the steady-state operation. This power oscillation contains a series of low-order frequency components, which is reflected in the frequency components of the amplitude of the output current $|i_g|$. When multiplying the amplitude of the output current $|i_g|$ with the phase angle $\sin(\theta_g)$, the output current i_g will contain a certain amount of interharmonic frequencies due to the amplitude modulation following the control diagram in Fig. 1.

To address this issue, a model to predict the interharmonic characteristic in PV systems has been proposed in [8], where the results from the interharmonic model agree well with the field observation in [6]. It has been demonstrated in [8] that the interharmonic characteristic is strongly dependent on the MPPT algorithm parameters such as the perturbation step-size v_{step} and the sampling rate f_{MPPT} . As discussed in [8], the interharmonic emission can be effectively alleviated by reducing the sampling rate of the MPPT algorithm. However, this will inevitably slow down the tracking performance of the MPPT algorithm [9], which may reduce the MPPT efficiency and thus the PV energy yield, especially during changing environmental conditions (e.g., solar irradiance and ambient temperature). Thus, there is a trade-off between the interharmonic emission and the MPPT efficiency when selecting the sampling rate of the MPPT algorithm.

With the above motivation, a new mitigating solution for interharmonics in PV systems is proposed in this paper. The proposed method randomly switches the operation between a fast and slow sampling rate of the MPPT algorithm. By doing so, the interharmonics in the

TABLE I
PARAMETERS OF THE SINGLE-PHASE GRID-CONNECTED PV SYSTEM

PV rated power	3 kW
DC-link capacitor	$C_{dc} = 1100 \mu\text{F}$
LC-filter	$L_{inv} = 4.8 \text{ mH}$, $C_f = 4.3 \mu\text{F}$
Grid-side inductance	$L_g = 2 \text{ mH}$
Switching frequency	$f_{inv} = 8 \text{ kHz}$
Controller sampling frequency	$f_s = 20 \text{ kHz}$
Grid nominal voltage (RMS)	$V_g = 230 \text{ V}$
Grid nominal frequency	$f_g = 50 \text{ Hz}$

output current can be effectively reduced due to the distribution of the frequency spectrum. On the other hand, the MPPT performance of the proposed method can be maintained similar to the case when employing a fast MPPT sampling rate. This paper is organized as follows. The interharmonics in PV systems are discussed in Section II, where the impact of the MPPT sampling rate is considered. Then, the interharmonic mitigating solution is proposed in Section III, and its performance is validated experimentally in terms of interharmonic reduction and also MPPT efficiency. Finally, concluding remarks are given in Section IV.

II. INTERHARMONICS IN PHOTOVOLTAIC SYSTEMS

A. System Configuration

The experimental test in this paper is conducted based on the single-stage single-phase PV inverter shown in Fig. 1, where the system parameters are given in Table I. In this configuration, the PV inverter is employed to control the power extraction from the PV arrays and convert it to the ac power delivered to the grid [10]. In order to maximize the PV energy yield, the operating voltage of the PV arrays (i.e., corresponding to the dc-link voltage v_{dc}) is determined by the MPPT algorithm during the operation. The dc-link voltage v_{dc} is regulated through the control of the output current i_g by a current controller, where the phase angle of the output current $\sin(\theta_g)$ is obtained using a phase-locked loop (PLL).

B. Maximum Power Point Tracking

The MPPT algorithm is essential for the PV system in order to maintain the operating point of the PV arrays close to the MPP and thus maximize the energy yield during the operation. In this paper, the Perturb and Observe (P&O) MPPT algorithm is employed [9], where the perturbation step-size v_{step} and the MPPT sampling rate f_{MPPT} are the MPPT parameters.

One important characteristic of the P&O MPPT algorithm (and also other hill-climbing MPPT methods) is the power oscillation during the steady-state operation [9]. This behavior is shown in Fig. 2, where the PV inverter operates under constant solar irradiance condition. Two MPPT sampling rates of 2.5 and 5 Hz are employed to demonstrate the performance of the PV system with different MPPT sampling rates. Comparing the operating condition with two times difference in the sampling rate can clearly demonstrate their impact on the interharmonic characteristics. It can be seen that the PV arrays voltage oscillates within three operating points, which correspond to the ‘‘top of the hill’’ in the power-voltage characteristic of the PV arrays. This is achieved when the sampling rate is properly selected below the PV-power settling time as discussed in [11]. Notably, the frequency of the oscillation is proportional to the MPPT sampling rate.

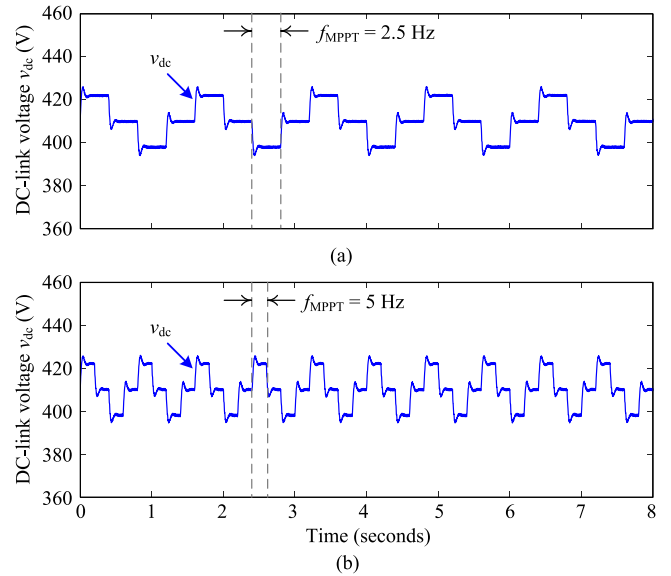

Fig. 2. Experimental waveforms of the dc-link voltage v_{dc} of the PV inverter operated at 10% of the rated power (i.e., 0.3 kW) with the MPPT sampling rate of (a) $f_{MPPT} = 2.5 \text{ Hz}$ and (b) $f_{MPPT} = 5 \text{ Hz}$.

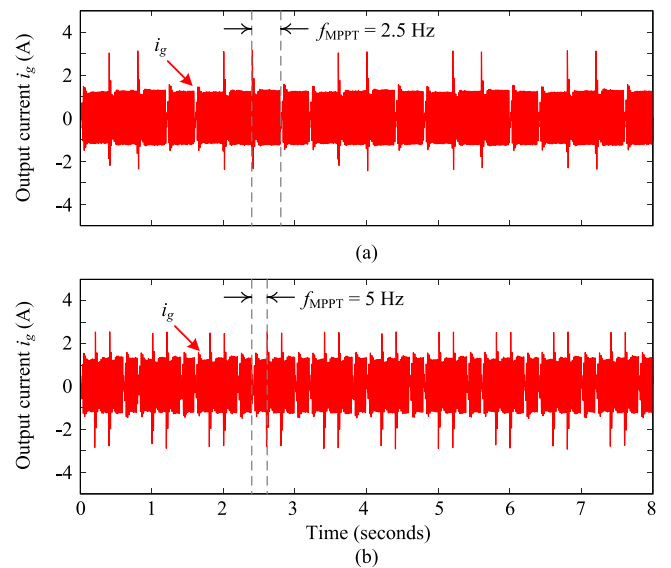

Fig. 3. Experimental waveforms of the output current i_g of the PV inverter operated at 10% of the rated power (i.e., 0.3 kW) with the MPPT sampling rate of (a) $f_{MPPT} = 2.5 \text{ Hz}$ and (b) $f_{MPPT} = 5 \text{ Hz}$.

C. Interharmonic Characteristics

Since the amplitude of the output current is determined by the response of the dc-link voltage controller following the control diagram in Fig. 1, the power oscillation will also be reflected in the output current as it is shown in Fig. 3. When analyzing the frequency spectrum of the output current, the interharmonics can be observed as it is shown in Fig. 4.

From the frequency spectrum of the output current shown in Fig. 4, it can be seen that the peak amplitude of the interharmonics increases from 0.07 to 0.15 A when the MPPT sampling rate increases from 2.5 to 5 Hz. Moreover, the distance between the consecutive interharmonic frequencies is also proportional to the MPPT sampling rate. These interharmonic characteristics have been explained with the model in [8],

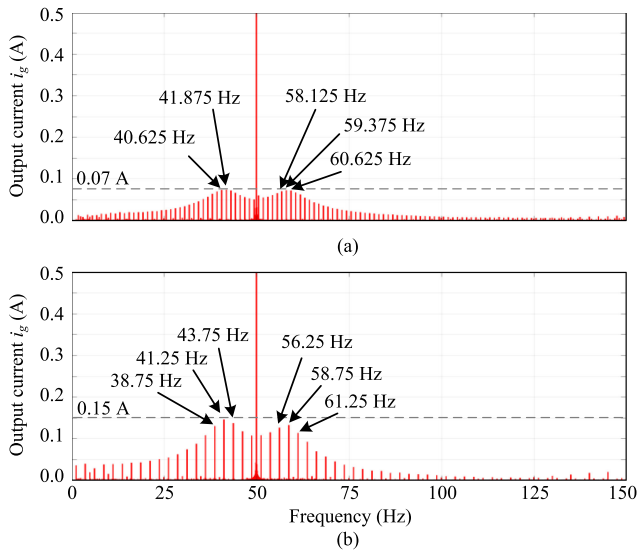

Fig. 4. Frequency spectrum of the output current i_g of the PV inverter operated at 10% of the rated power (i.e., 0.3 kW) with the MPPT sampling rate of (a) $f_{MPPT} = 2.5$ Hz and (b) $f_{MPPT} = 5$ Hz.

where the interharmonic emission is more pronounced when applying a high MPPT sampling rate.

III. MITIGATION OF INTERHARMONICS

In this section, the mitigation of the interharmonics through the modification of MPPT sampling rate is proposed, and its performances are evaluated experimentally.

A. Modifying MPPT Sampling Rate

Conventionally, the P&O MPPT algorithm is implemented with a fixed sampling rate, where a high sampling rate offers a high MPPT efficiency during fast changing environmental conditions [12]. However, as it has been shown in Fig. 4(b), this can introduce certain interharmonics in the output current.

One solution to reduce the dominant interharmonics in the output current is by employing a random sampling rate for the MPPT algorithm. This idea is similar to the random pulse-width modulation (PWM) discussed in the previous research for the PWM switching harmonic reduction [13]. However, in the proposed method, the random selection of the sampling rate is applied at the MPPT algorithm. One simple way to implement this method is by randomly select the MPPT algorithm sampling rate either at a high f_{fast} or low f_{slow} value during the operation, which can be summarized as

$$f_{MPPT} = \begin{cases} f_{fast}, & \text{when } X \leq 0.5 \\ f_{slow}, & \text{when otherwise} \end{cases} \quad (1)$$

where $X \sim U(0, 1)$ is a random variable with uniform distribution between 0 and 1. Notably, there are also other ways to randomly generate different sampling rates during the operation, which is an interesting aspect for future research.

This principle is demonstrated in Fig. 5, where the MPPT sampling rates are $f_{slow} = 2.5$ Hz and $f_{fast} = 5$ Hz. Notably, the other control parameters are kept the same as in the previous cases in Figs. 2 and 3. It can be seen from the experimental results in Fig. 5(a) that the perturbation of the dc-link voltage becomes more arbitrary due to the randomly applied MPPT sampling rate. It is worth to mention that the proposed method can also be applied to other hill-climbing MPPT

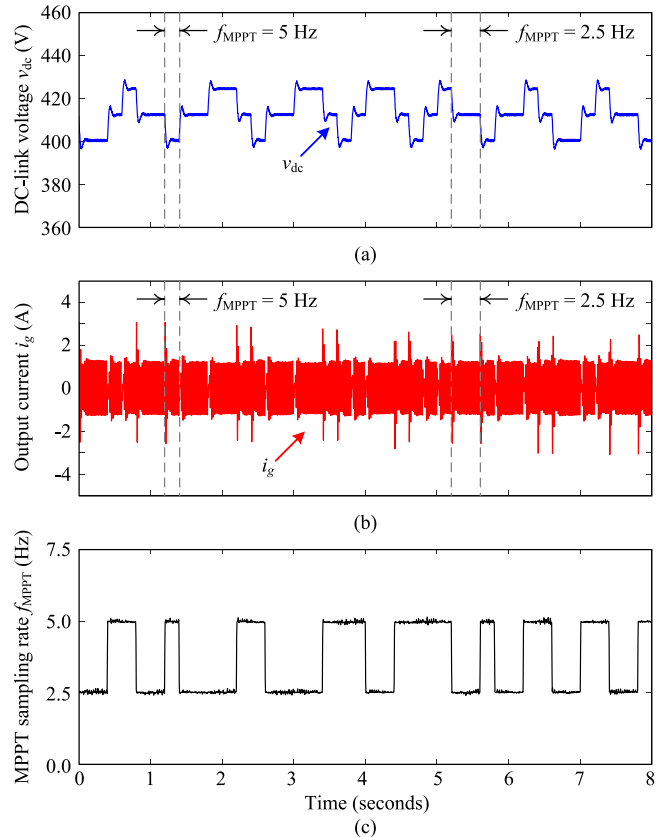

Fig. 5. Experimental results of the PV inverter operated at 10% of the rated power (i.e., 0.3 kW) with randomly applied MPPT sampling rate of $f_{slow} = 2.5$ Hz and $f_{fast} = 5$ Hz. (a) DC-link voltage v_{dc} . (b) Output current i_g . (c) MPPT sampling rate f_{MPPT} .

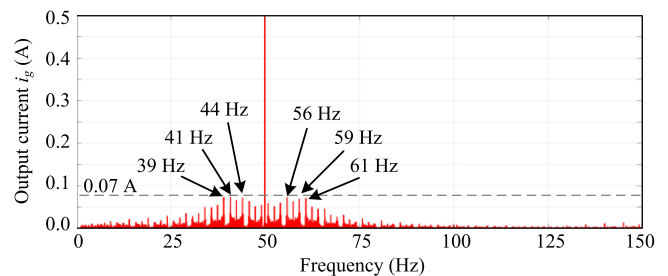

Fig. 6. Frequency spectrum of the output current i_g of the PV inverter operated at 10% of the rated power (i.e., 0.3 kW) with randomly applied MPPT sampling rate of $f_{slow} = 2.5$ Hz and $f_{fast} = 5$ Hz.

methods (e.g., incremental conductance algorithm) as well since the MPPT implementation is in principle similar.

B. Interharmonic Reduction

The consequence of randomly applying the MPPT sampling rate is also reflected in the perturbation rate of the output current. In Fig. 5(b), the output current with the proposed randomly applied MPPT sampling rate of $f_{slow} = 2.5$ Hz and $f_{fast} = 5$ Hz is shown. The corresponding MPPT sampling rate during the operation is also demonstrated in Fig. 5(c). When analyzing the frequency spectrum of the output current in Fig. 5(b), it can be observed from the results in Fig. 6 that the dominant interharmonics in the output current can be reduced significantly. With the proposed method, the peak amplitude of the interharmonics is

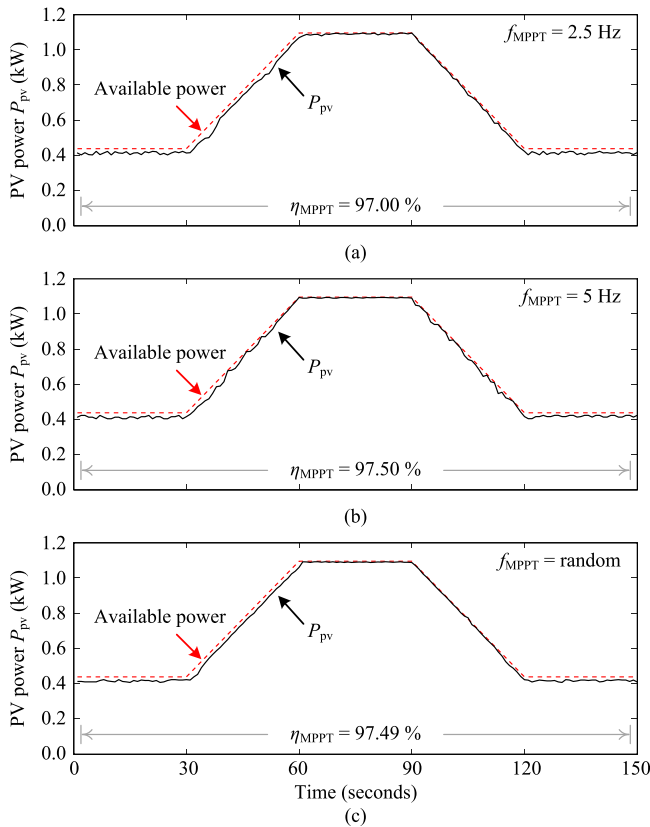

Fig. 7. Measured PV power extraction of the PV inverter under the trapezoidal solar irradiance condition with the MPPT sampling rate of (a) $f_{\text{MPPT}} = 2.5$ Hz, (b) $f_{\text{MPPT}} = 5$ Hz, and (c) $f_{\text{MPPT}} = \text{random}$.

0.07 A, which is less than half of the case when employing a fast MPPT sampling rate in Fig. 4(b). In fact, the frequency spectrum is more distributed due to the randomly applied perturbation of the output current. This is preferable since a certain interharmonic component may trigger an undamped resonance, causing stability problem. Moreover, in the case of parallel-connected PV inverters, the stochastic behavior of perturbation has a high probability to counteract one another due to its randomness. This can potentially smooth out the total power oscillation and thereby further reduce the interharmonics in the total output current.

C. MPPT Efficiency

The tracking performance of the MPPT algorithm is evaluated by means of the MPPT efficiency: $\eta_{\text{MPPT}} = E_{\text{pv}}/E_{\text{avail}}$, where E_{pv} and E_{avail} are the total extracted and available PV energy, respectively. The MPPT operation with different sampling rates under a trapezoidal solar irradiance condition is shown in Fig. 7. According to the results, the higher MPPT sampling rate offers a better tracking performance during the changing solar irradiance condition. This can be observed by comparing the PV output power during the increasing solar irradiance condition (i.e., from $t = 30$ s to $t = 60$ s) in Figs. 7(a) and (b). In that case, the MPPT efficiency of the operation with $f_{\text{MPPT}} = 5$ Hz is 0.5% higher than the case when applying $f_{\text{MPPT}} = 2.5$ Hz, resulting in a higher energy yield.

Considering the operation with the proposed randomly applied MPPT sampling rate in Fig. 7(c), the tracking performance of the MPPT operation is somewhat in between the slow and the fast MPPT sampling rate operations. Although the PV output power cannot follow

the change in the available power as fast as the case with $f_{\text{MPPT}} = 5$ Hz, it shows a significant improvement compared to the case with $f_{\text{MPPT}} = 2.5$ Hz. This improvement can be measured from the MPPT efficiency η_{MPPT} , which is very close to the case with $f_{\text{MPPT}} = 5$ Hz. Thus, a high MPPT performance can be achieved with the proposed interharmonic mitigating solution.

IV. CONCLUSION

With the conventional MPPT implementation, there is a trade-off between the interharmonic emission and the MPPT efficiency when selecting the sampling rate of the MPPT algorithm. To solve this issue, a new mitigating solution for the interharmonics in PV systems has been proposed in this paper. The proposed method modifies the MPPT algorithm by randomly selecting the sampling rate of the MPPT algorithm during the operation. By doing so, the frequency spectrum of the output current can be smoothed and the amplitude of the dominant interharmonics can be significantly reduced. Moreover, the MPPT performance of the proposed mitigating solution can be maintained close to the conventional MPPT operation with a fast MPPT sampling rate, where similar tracking efficiency during a dynamic operating condition can be achieved. The performance of the proposed method has been validated experimentally under both steady-state (e.g., interharmonics) and dynamic operations (e.g., MPPT efficiency).

REFERENCES

- [1] M. Aiello, A. Cataliotti, S. Favuzza, and G. Graditi, "Theoretical and experimental comparison of total harmonic distortion factors for the evaluation of harmonic and interharmonic pollution of grid-connected photovoltaic systems," *IEEE Trans. Power Del.*, vol. 21, no. 3, pp. 1390–1397, Jul. 2006.
- [2] T. Messo, J. Jokipii, A. Aapro, and T. Suntio, "Time and frequency-domain evidence on power quality issues caused by grid-connected three-phase photovoltaic inverters," in *Proc. Eur. Conf. Power Electron. Appl.*, Aug. 2014, pp. 1–9.
- [3] R. Langella, A. Testa, S. Z. Djokic, J. Meyer, and M. Klatt, "On the interharmonic emission of PV inverters under different operating conditions," in *Proc. Int. Conf. Harmonics Quality Power*, Oct. 2016, pp. 733–738.
- [4] R. Langella, A. Testa, J. Meyer, F. Miller, R. Stiegler, and S. Z. Djokic, "Experimental-based evaluation of PV inverter harmonic and interharmonic distortion due to different operating conditions," *IEEE Trans. Instrum. Meas.*, vol. 65, no. 10, pp. 2221–2233, Oct. 2016.
- [5] P. Pakonen, A. Hilden, T. Suntio, and P. Verho, "Grid-connected PV power plant induced power quality problems—experimental evidence," in *Proc. Eur. Conf. Power Electron. Appl.*, Sep. 2016, pp. 1–10.
- [6] V. Ravindran, S. K. Rnnberg, T. Busatto, and M. H. J. Bollen, "Inspection of interharmonic emissions from a grid-tied PV inverter in north Sweden," in *Proc. Int. Conf. Harmonics Quality Power*, pp. 1–6, May 2018.
- [7] A. Testa *et al.*, "Interharmonics: Theory and modeling," *IEEE Trans. Power Del.*, vol. 22, no. 4, pp. 2335–2348, Oct. 2007.
- [8] A. Sangwongwanich, Y. Yang, D. Sera, H. Soltani, and F. Blaabjerg, "Analysis and modeling of interharmonics from grid-connected photovoltaic systems," *IEEE Trans. Power Electron.*, vol. 33, no. 10, pp. 8353–8364, Oct. 2018.
- [9] N. Femia, G. Petrone, G. Spagnuolo, and M. Vitelli, "Optimization of perturb and observe maximum power point tracking method," *IEEE Trans. Power Electron.*, vol. 20, no. 4, pp. 963–973, Jul. 2005.
- [10] S. B. Kjaer, J. K. Pedersen, and F. Blaabjerg, "A review of single-phase grid-connected inverters for photovoltaic modules," *IEEE Trans. Ind. Appl.*, vol. 41, no. 5, pp. 1292–1306, Sep. 2005.
- [11] J. Kivimäki, S. Kolesnik, M. Sitbon, T. Suntio, and A. Kuperman, "Design guidelines for multiloop perturbative maximum power point tracking algorithms," *IEEE Trans. Power Electron.*, vol. 33, no. 2, pp. 1284–1293, Feb. 2018.
- [12] H. Schmidt, B. Burger, U. Bussemas, and S. Elies, "How fast does an MPP tracker really need to be?" in *Proc. Eur. Photovoltaic Solar Energy Conf.*, Sep. 2009, pp. 3273–3276.
- [13] F. Blaabjerg, J. K. Pedersen, and P. Thøgersen, "Improved modulation techniques for PWM-VSI drives," *IEEE Trans. Ind. Electron.*, vol. 44, no. 1, pp. 87–95, Feb. 1997.