

A Highly Robust Single-Loop Current Control Scheme for Grid-Connected Inverter With an Improved *LCCL* Filter Configuration

Donghua Pan¹, Member, IEEE, Xinbo Ruan², Fellow, IEEE, Xiongfei Wang³, Senior Member, IEEE, Frede Blaabjerg⁴, Fellow, IEEE, Xuehua Wang, Member, IEEE, and Qingfeng Zhou⁵, Student Member, IEEE

I. INTRODUCTION

Abstract—Single-loop current control is an attractive scheme for the *LCL*-type grid-connected inverter due to its simplicity and low cost. However, conventional single-loop control schemes, which command either the inverter current or the grid current, are subject to the specific resonance frequency regions. The weighted average current control, which splits the filter capacitor into two parts (in form of an *LCCL* filter) and commands the current flowing between these two parts, is independent of the resonance frequency, but on the other hand, it is limited by the poor sensitivity to the grid impedance variation and weak stability in the grid current. These limitations are comprehensively explained in this paper and then addressed by identifying that the single-loop weighted average current control is equivalent to the dual-loop grid current control with an inherent capacitor current active damping. By tuning the capacitor split proportion as a second degree of freedom, an optimal damping performance that is robust to the grid impedance variation can be naturally achieved using only the inherent damping. Thus, no extra damping is required, and the single-loop structure with only one current sensing turns to be adequate. Moreover, for convenience of practical implementation, an improved *LCCL* filter configuration is proposed to allow the use of two equal nominal capacitances for the split capacitors. Finally, experiments are performed to verify the effectiveness of the proposed method.

Index Terms—Active damping, grid-connected inverter, grid impedance, *LCCL* filter, single-loop control.

Manuscript received September 11, 2017; revised November 27, 2017; accepted December 4, 2017. Date of publication December 13, 2017; date of current version July 15, 2018. This work was supported by the National Natural Science Foundation of China under Award 50837003. Recommended for publication by Associate Editor M. S. ElMoursi.

D. Pan was with the State Key Laboratory of Advanced Electromagnetic Engineering and Technology, School of Electrical and Electronic Engineering, Huazhong University of Science and Technology, Wuhan 430074, China. He is now with the Department of Energy Technology, Aalborg University, Aalborg 9220, Denmark (e-mail: dop@et.aau.dk).

X. Ruan is with the State Key Laboratory of Advanced Electromagnetic Engineering and Technology, School of Electrical and Electronic Engineering, Huazhong University of Science and Technology, Wuhan 430074, China, and also with the Center for More-Electric-Aircraft Power Systems, College of Automation Engineering, Nanjing University of Aeronautics and Astronautics, Nanjing 210016, China (e-mail: ruanxb@nuaa.edu.cn).

X. Wang and F. Blaabjerg are with the Department of Energy Technology, Aalborg University, Aalborg 9220, Denmark (e-mail: xwa@et.aau.dk; fbl@et.aau.dk).

X. Wang and Q. Zhou are with the State Key Laboratory of Advanced Electromagnetic Engineering and Technology, School of Electrical and Electronic Engineering, Huazhong University of Science and Technology, Wuhan 430074, China (e-mail: wang.xh@hust.edu.cn; zqf@hust.edu.cn).

Color versions of one or more of the figures in this paper are available online at <http://ieeexplore.ieee.org>.

Digital Object Identifier 10.1109/TPEL.2017.2783301

AS AN efficient power conversion interface, the grid-connected inverter with an *LCL* filter has been widely used to convert the dc power to the high-quality ac power and feed it into the grid [1]–[4]. The use of *LCL* filter offers an effective attenuation of the switching harmonics, but it faces also potential resonance problems [5]–[8]. Fortunately, without damping the *LCL*-filter resonance, a single-loop control scheme, which commands either the inverter current or the grid current, is found to be possible to stabilize the system. The stability of such a single loop depends on the ratio of the resonance frequency f_r to the sampling frequency f_s , due to the computation and pulse-width modulation (PWM) delays. With a total delay of T_d , the critical resonance frequency f_{crit} is proved to be $1/(4T_d)$ [9], [10]. The stable region is $f_r < f_{crit}$ for the inverter current control and $f_r > f_{crit}$ for the grid current control. Typically, $T_d = 1.5T_s$ (T_s is the sampling period), thus, $f_{crit} = f_s/6$ [11]–[13]. To retain a stable operation, the *LCL* filter should be carefully designed with its resonance frequency falling into the stable region [14], [15]. Note that a lower f_r calls for larger filter inductors or filter capacitor, thereby $f_r > f_s/6$ would be most cost-effective. This is, however, not always possible in practice, since the variation of grid impedance may shift f_r across $f_s/6$ [16].

To address this issue, an intuitive method is to widen the stable region, so that it can tolerate a wider range variation of the resonance frequency. Achieving this goal, for the inverter current control, requires to increase f_{crit} by reducing the delay T_d , whereas to decrease f_{crit} by adding another delay to T_d for the grid current control. The additional delay will impose a further limitation on the control bandwidth and, thus, it is not generally recommended. When it comes to the delay reduction, the state observer [17], the real-time sampling and update schemes [18]–[20], and the phase-lead compensators [21]–[25] can be used. To avoid the model-dependent nature of the state observer, a real-time sampling scheme, which shifts the sampling instant toward the PWM reference update instant, is proposed in [18]. Although it is simple, the implementation is susceptible to aliasing due to the asynchronous sampling process. An alternative solution is to update the PWM reference immediately after it is being computed while keeping the synchronous sampling. In this way, the aliasing is avoided, but the computation time for controller processing must be very short and not exceed $0.25T_s$ [19], [20].

Thus, it is mainly suitable for high-power application where the switching/sampling frequency is relatively low. Phase-lead compensation can be achieved with a lead-lag element [21], a first-order lead compensator [22], [23], and a second-order generalized integrator [24]. A graphical evaluation of these methods is presented in [25], which reveals that they can compensate a maximum delay of a half sampling period but also lead to the amplification of high-frequency noise. Therefore, it is difficult to perform a practical delay reduction with a little side effect.

Besides controlling the inverter current or the grid current, an interesting single-loop scheme, which controls their weighted average value, is proposed in [26]–[29]. The weighted average current can be obtained by either splitting the capacitor of the *LCCL* filter into two parts (in form of an *LCCL* filter) and measuring the current flowing between these two parts [26], or directly measuring both the inverter current and the grid current and then weighting them [27]–[29]. By selecting a proper weight value, the control system can be degraded from a third-order system to a first-order one, like the *L*-filtered grid-connected inverter. Thus, its target control variable, i.e., the weighted average current, is exempt from the *LCCL*-filter resonance and can easily be stabilized. However, the reduction of control order relies on an exact knowledge of the grid inductance, which means it is sensitive to the grid impedance variation. Moreover, recent research in [30] shows that even if the control order can be reduced, an implicit resonance hazard still exists in both the inverter current and the grid current, and it will lead to the *critically stable* operations of these two currents. An extra active damping, e.g., the capacitor current active damping [31], can be introduced as an inner loop to solve these problems. Although effective, it loses the benefits of the single-loop control in terms of simplicity and cost.

A robust and practical single-loop current control scheme is therefore urgently demanded. Without any delay addition or reduction, the single-loop weighted average current control is the focus in this paper, and it is implemented by the *LCCL* filter method with only one current sensor being used. The objective of the weighted average current control is to improve the system robustness in our work, rather than to reduce the control order in conventional applications. Through transformation of the control block diagram, the single-loop weighted average current control is found to be equivalent to the dual-loop grid current control with an inherent capacitor current active damping. This inherent damping is determined by the proportion of the split capacitor (i.e., weight value), which if properly designed, can yield an *optimal damping* performance that is robust to the grid impedance variation. Thus, no extra damping is required, and the advantages of the single-loop control are preserved. Upon drawing such method, the practical issue, such as the nominal capacitance, is taken into account. An immediate influence brought by this issue is the deviation of the optimal damping. To compensate for this, an improved *LCCL* filter configuration is proposed.

This paper begins with a discussion on the limitations of conventional weighted average current control in Section II. To break the limitations, a robust single-loop weighted average

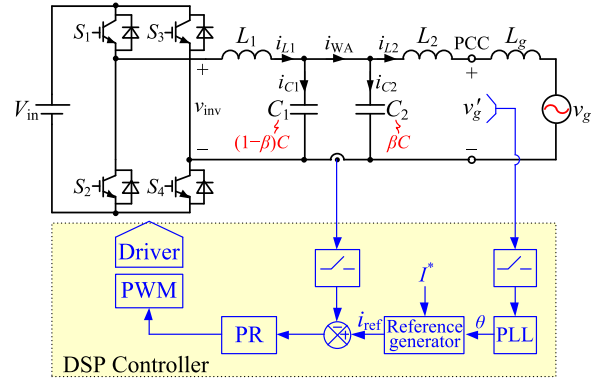

Fig. 1. Weighted average current control for a single-phase grid-connected inverter with an *LCCL* filter.

current control with an optimal inherent damping is proposed in Section III. The proposed method is drawn based on a system with a random time delay, thus, it is applicable to different PWM update schemes. The improved *LCCL* filter configuration, which makes the proposed method more practical, is elaborated in Section IV. Experimental results are provided to confirm the theoretical expectations in Section V. Meanwhile, the effects of the parasitic resistor and the capacitance deviation are also verified in this section. Finally, Section VI concludes this paper.

II. LIMITATIONS OF CONVENTIONAL WEIGHTED AVERAGE CURRENT CONTROL

A. System Description and Modeling

Fig. 1 shows a single-phase voltage-source inverter feeding into the grid through an *LCCL* filter. For convenience of illustration, the *LCCL* filter is shown in the form of an *LCCL* topology, where the capacitor *C* is split into two parts *C*₁ and *C*₂. *L*₁ is the inverter-side inductor, *L*₂ is the grid-side inductor, and *L*_g is the grid inductance at the point of common coupling (PCC). Depending on the grid configuration, *L*_g may vary in a wide range, which, thus, calls for a robust control scheme in order to stabilize the system.

Such a robust operation is usually performed by controlling either the inverter current *i*_{L1} or the grid current *i*_{L2} with an extra active damping [30], i.e., a dual-loop strategy. Here, it is evaluated based on a single-loop scheme, which commands the weighted average value of *i*_{L1} and *i*_{L2}. Referring to Fig. 1, if the proportions of *C*₁ and *C*₂ are $1 - \beta$ and β with respect to the total capacitance *C*, i.e., $C = C_1 + C_2$, $C_1 = (1 - \beta)C$, and $C_2 = \beta C$, then $i_{C1} = (1 - \beta)i_C$ and $i_{C2} = \beta i_C$, where *i*_{C1}, *i*_{C2}, and *i*_C are the currents of *C*₁, *C*₂, and *C*, respectively. Hence, the current flowing between *C*₁ and *C*₂ can be obtained as

$$\begin{aligned} i_{WA} &= i_{L2} + i_{C2} = i_{L2} + \beta i_C = i_{L2} + \beta(i_{L1} - i_{L2}) \\ &= \beta i_{L1} + (1 - \beta) i_{L2}. \end{aligned} \quad (1)$$

Equation (1) indicates that *i*_{WA} is exactly the target weighted average current, with β and $1 - \beta$ being the weight values of *i*_{L1} and *i*_{L2}. Thus, by adopting the *LCCL* topology, *i*_{WA} can be

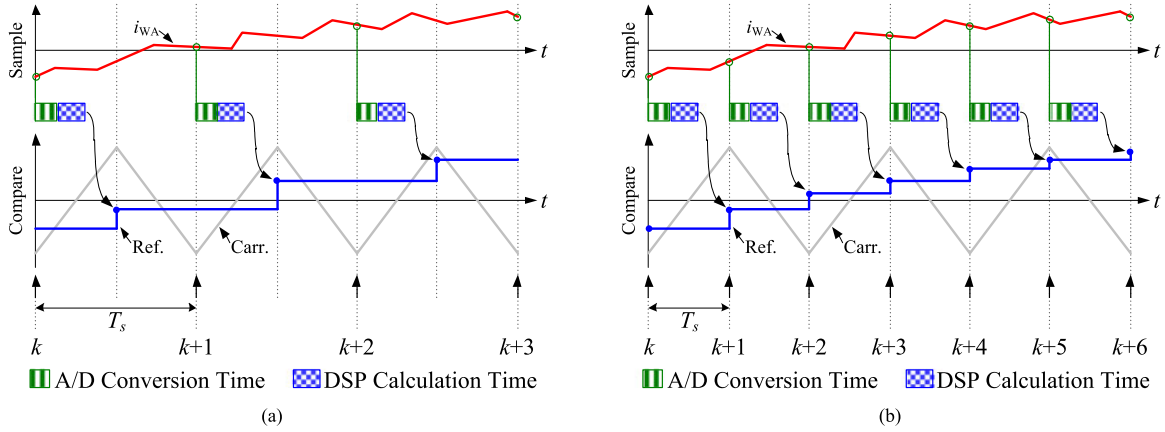

Fig. 2. Computation and PWM delays inherent in the digital PWM. (a) Single update mode, $T_d = T_s$ ($f_s = f_{sw}$). (b) Dual update mode, $T_d = 1.5T_s$ ($f_s = 2f_{sw}$).

directly measured with only one current sensor, which surely saves the cost.

A phase-locked loop (PLL) is used to synchronize the inverter with the PCC voltage v'_g . The phase angle extracted by the PLL and the demanded current amplitude I^* are sent to a reference generator to generate the current reference i_{ref} . The phase shift caused by $L_2 - C_2$ is compensated in this generator in order to control the power factor on the grid side. i_{WA} is compared to i_{ref} , and the error signal is sent to a proportional-resonant (PR) regulator, whose output is then fed to a digital PWM modulator.

The digital modulator contains computation and PWM delays [10], [32], [33]. The delay mechanism is shown in Fig. 2, where two PWM update modes are considered. In the single update mode, the sampling is taken either at the beginning or in the middle of a switching period, which means the sampling frequency f_s is equal to the switching frequency f_{sw} . Provided that the total time for A/D conversion and DSP calculation is shorter than $0.5T_s$, the modulation reference can be updated just until the middle of the sampling period (rather than the end), giving a computation delay of $0.5T_s$. In the dual update mode, samplings are taken both at the beginning and in the middle of a switching period, i.e., $f_s = 2f_{sw}$ (twice that in the single update mode), and the modulation reference is updated at the end of the sampling period, giving a computation delay of T_s . For convenience of illustration, the computation delay is defined as λT_s ($0.5 \leq \lambda \leq 1$), and it is expressed as $e^{-s\lambda T_s}$.

The PWM delay is caused by the zero-order hold (ZOH) effect which keeps the modulation reference constant after it has been updated, and it is definitely $0.5T_s$ in either mode. Thereby, the dual update mode which has a smaller T_s , and thus a smaller delay, is more attractive in practice. For the sake of generality, both modes are analyzed here, and the total delay is $T_d = (\lambda + 0.5)T_s$.

A block diagram that accounts for these delays is shown in Fig. 3, where i_{WA} is depicted by the summation of i_{L2} and βi_C referring to (1). $G_i(z)$ is the PR regulator. $G_h(s)$ is the transfer function of the ZOH, and it is expressed as

$$G_h(s) = \frac{1 - e^{-sT_s}}{s}. \quad (2)$$

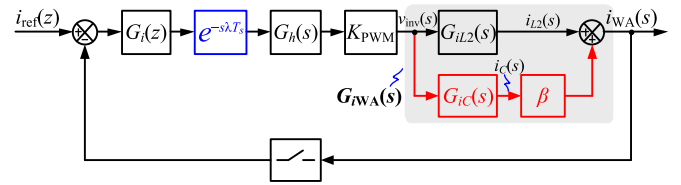

Fig. 3. Block diagram of the weighted average current control.

$K_{PWM} = V_{in}/V_{tri}$ is the gain of the PWM inverter, where V_{in} is the input voltage, and V_{tri} is the amplitude of the triangular carrier. $G_{iC}(s)$ and $G_{iL2}(s)$ are the transfer functions from the inverter output voltage $v_{inv}(s)$ to $i_C(s)$ and $i_{L2}(s)$, and they are expressed as

$$G_{iC}(s) = \frac{i_C(s)}{v_{inv}(s)} = \frac{1}{L_1} \cdot \frac{s}{s^2 + \omega_r^2}$$

$$G_{iL2}(s) = \frac{i_{L2}(s)}{v_{inv}(s)} = \frac{1}{s(L_1 + L_2 + L_g)} \cdot \frac{\omega_r^2}{s^2 + \omega_r^2} \quad (3)$$

where ω_r is the LCL-filter resonance angular frequency and expressed as

$$\omega_r = 2\pi f_r = \sqrt{\frac{L_1 + L_2 + L_g}{L_1(L_2 + L_g)C}}. \quad (4)$$

According to (3), the transfer function from $v_{inv}(s)$ to $i_{WA}(s)$, shown as the shaded area in Fig. 3, can be obtained as

$$G_{iWA}(s) = G_{iL2}(s) + \beta G_{iC}(s)$$

$$= \frac{\beta(L_1 + L_2 + L_g)s^2 + \omega_r^2 L_1}{sL_1(L_1 + L_2 + L_g)(s^2 + \omega_r^2)}. \quad (5)$$

From (5), it can be found that if β is equal to

$$\beta = \frac{L_1}{L_1 + L_2 + L_g} \quad (6)$$

then the resonant poles and zeros will cancel out with each other, and $G_{iWA}(s)$ can be simplified

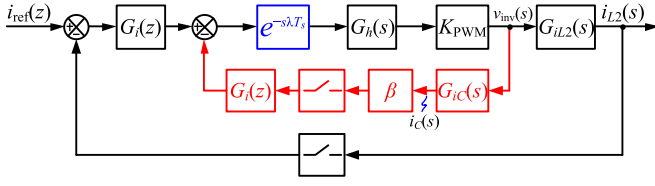

Fig. 4. Equivalent transformation of the block diagram of the weighted average current control.

as

$$G_{i_{WA}}(s) = \frac{1}{s(L_1 + L_2 + L_g)}. \quad (7)$$

From (7), it is obvious that $G_{i_{WA}}(s)$ is the same as the transfer function of the L filter with $L = L_1 + L_2 + L_g$. That means, by splitting the capacitor with a proportion $\beta = L_1/(L_1 + L_2 + L_g)$, the control system is degraded from a third-order system to a first-order one, like the L -filtered grid-connected inverter, thus, its target control variable i_{WA} can easily be stabilized. This property is identified as the main benefit of the weighted average current control in conventional applications [26]–[29].

To exploit such benefit, the grid inductance L_g should be known exactly to meet the desired split proportion shown in (6). This is difficult for the weak grid conditions, where the varying L_g will lead to the failures in meeting (6) and then the counteraction of the resonance in $G_{i_{WA}}(s)$. As a result, the control performance and system stability will be impaired, implying a poor robustness. However, even in a stiff grid where (6) can be perfectly met, there is still a serious stability challenge faced by the grid current. In [30], this stability issue is discussed for $\lambda = 1$. To complete the work, the situation of a random λ is further analyzed as follows.

B. Stability Analysis From the Perspective of Grid Current

Note that the grid current is indirectly controlled and its stability is covered up in the model depicted in Fig. 3. An equivalent transformation of Fig. 3 is made in order to account for the grid current stability. By separating the feedback paths of i_{L2} and i_C , and relocating the feedback node of i_C to the output of $G_i(z)$, an equivalent block diagram is obtained, as shown in Fig. 4. It can be seen that the equivalent model is exactly

a dual-loop structure, which involves an outer loop in charge of the grid current control and an inner loop implementing the capacitor current active damping. Moreover, the damping function is $\beta G_i(z)$. This part of damping is not extra introduced, but naturally comes along with the feedback of i_{WA} which contains a part of the capacitor current βi_C [see $i_{WA} = i_{L2} + \beta i_C$ in (1)], thus it is called the inherent damping.

Since i_{L2} is the equivalent target control variable in Fig. 4, its stability now turns to be explicit. To perform an accurate stability analysis in the z domain, the continuous transfer functions in Fig. 4 are discretized by applying the ZOH transform, as given in (8a) and (8b), shown at the bottom of this page.

Then, the system discrete loop gain with regard to i_{L2} can be derived as (9), shown at the bottom of this page.

An interesting feature observed from $T_{i_{L2}}(z)$ is that at the resonance frequency, there is

$$z = z_{1,2} = e^{\pm j\omega_r T_s} \Rightarrow z^2 - 2z \cos \omega_r T_s + 1 = 0 \quad (10)$$

and then $T_{i_{L2}}(z)$ can be simplified as

$$\begin{aligned} T_{i_{L2}}(z_{1,2}) &= -\frac{1}{\beta K_{PWM} G_i(z)} \cdot \frac{L_1 K_{PWM} G_i(z)}{L_1 + L_2 + L_g} \\ &= -\frac{1}{\beta} \cdot \frac{L_1}{L_1 + L_2 + L_g}. \end{aligned} \quad (11)$$

Obviously, for $\beta = L_1/(L_1 + L_2 + L_g)$, $T_{i_{L2}}(z_{1,2}) = -1$. That means, $z_{1,2}$ is a pair of imaginary roots of the characteristic equation $1 + T_{i_{L2}}(z) = 0$, which, in other words, is a pair of closed-loop resonant poles located at the unit circle ($|z_{1,2}| = 1$). Due to this pair of resonant poles, i_{L2} can only be critically stable even though i_{WA} has been stabilized. Moreover, this critically stable feature is deduced based on a random λ , which means it is independent of the time delay. From this point of view, the conventional weighted average current control does not essentially remove the LCL -filter resonance, but “hide” it in the grid current.

III. ROBUST SINGLE-LOOP WEIGHTED AVERAGE CURRENT CONTROL WITH OPTIMAL INHERENT DAMPING

As discussed above, the conventional single-loop weighted average current control is limited by its poor robustness and weak stability. To overcome these limitations, an extra active

$$Z_{ZOH} [G_{iC}(s) e^{-s\lambda T_s}] = \frac{z-1}{\omega_r L_1} \cdot \frac{z \sin(1-\lambda)\omega_r T_s + \sin \lambda \omega_r T_s}{z(z^2 - 2z \cos \omega_r T_s + 1)}. \quad (8a)$$

$$Z_{ZOH} [G_{iL2}(s) e^{-s\lambda T_s}] = \frac{\omega_r T_s [\lambda + (1-\lambda)z] (z^2 - 2z \cos \omega_r T_s + 1) - (z-1)^2 [z \sin(1-\lambda)\omega_r T_s + \sin \lambda \omega_r T_s]}{\omega_r (L_1 + L_2 + L_g) z (z-1) (z^2 - 2z \cos \omega_r T_s + 1)}. \quad (8b)$$

$$\begin{aligned} T_{i_{L2}}(z) &= \frac{K_{PWM} G_i(z) Z_{ZOH} [G_{iL2}(s) e^{-s\lambda T_s}]}{1 + \beta K_{PWM} G_i(z) Z_{ZOH} [G_{iC}(s) e^{-s\lambda T_s}]} = \frac{L_1 K_{PWM} G_i(z)}{L_1 + L_2 + L_g} \\ &\cdot \frac{\omega_r T_s [\lambda + (1-\lambda)z] (z^2 - 2z \cos \omega_r T_s + 1) - (z-1)^2 [z \sin(1-\lambda)\omega_r T_s + \sin \lambda \omega_r T_s]}{\omega_r L_1 z (z-1) (z^2 - 2z \cos \omega_r T_s + 1) + \beta K_{PWM} G_i(z) (z-1)^2 [z \sin(1-\lambda)\omega_r T_s + \sin \lambda \omega_r T_s]}. \end{aligned} \quad (9)$$

damping, e.g., the capacitor current active damping [31], can be introduced to form a dual-loop strategy. From the perspective of grid current, the extra damping introduces a second degree of freedom, so that the damping function is not fixed at $\beta G_i(z)$ [where $\beta = L_1/(L_1 + L_2 + L_g)$ for the control order reduction and $G_i(z)$ is specified by the outer current loop], but it can be tuned to avoid instability. Nevertheless, as a dual-loop control structure, increased cost and control complexity will be results from the extra damping, which are undesirable effects in practice.

In this section, the limitations of conventional weighted average current control are broken without changing its control architecture, i.e., remaining the single-loop manner. Since the reduction of control order does not show real advantage, instead, it brings an implicit resonance hazard, there is no need to fix β at $L_1/(L_1 + L_2 + L_g)$. The split proportion β itself can be tuned as a second degree of freedom to achieve an optimal inherent damping that is robust to a large grid impedance variation.

Recalling Fig. 4, the PR regulator $G_i(z)$ is incorporated in both the outer current loop and the inner active damping loop. For the stability analysis, $G_i(z)$ can be reduced to a proportional gain K_p , since the resonant gain has negligible effect above the fundamental frequency [11]. Thus, the damping function $\beta G_i(z)$ is simplified as a damping gain βK_p , with β being adjustable. Design of this damping gain is constrained by the gain margin (GM) on the loop gain $T_{iL_2}(z)$. These constraints have been derived for $\lambda = 1$ in [34], and they are extended to the situation of a random λ in the following section.

In the case of $\lambda = 1$, the GMs at f_r and $f_s/6$ needs to be concerned to ensure system stability [18], [34]. For a random λ , similar requirements also exist, except that $f_s/6$ is replaced by a general critical resonance frequency f_{crit} , i.e.

$$f_{\text{crit}} = \frac{1}{4T_d} = \frac{f_s}{4(\lambda + 0.5)}. \quad (12)$$

From (12), it is obvious that for $\lambda = 0.5$, $f_{\text{crit}} = f_s/4$; and for $\lambda = 1$, $f_{\text{crit}} = f_s/6$. Substituting $G_i(z) = K_p$ into (9), the GMs at f_r and f_{crit} , which are denoted by GM_1 and GM_2 (in decibels), respectively, can be obtained as (13a) and (13b), where (13b) is shown at the bottom of the page.

$$\text{GM}_1 = -20 \lg |T_{iL_2}(e^{j2\pi f_r T_s})| = 20 \lg \left(\beta \cdot \frac{L_1 + L_2 + L_g}{L_1} \right). \quad (13a)$$

In (13b), $K_{\text{d.crit}}$ is the critical damping gain [18], and it is expressed as

$$K_{\text{d.crit}} = \begin{cases} \frac{\omega_r L_1 \cos \omega_r T_s}{K_{\text{PWM}} \sin 0.5 \omega_r T_s}, & \lambda = 0.5 \\ \frac{\omega_r L_1 (2 \cos \omega_r T_s - 1)}{K_{\text{PWM}} \sin \omega_r T_s}, & \lambda = 1. \end{cases} \quad (14)$$

Similar to the case of $\lambda = 1$, the constraints on GM_1 and GM_2 for a random λ can also be derived, as shown in Table I, where three cases, namely Case I, Case II, and Case III, are defined depending on the resonance frequency and the damping gain.

From (13a), it is found that GM_1 is dependent only on β and filter/grid inductance, and it is equal to 0 dB for $\beta = L_1/(L_1 + L_2 + L_g)$, which confirms that i_{L_2} is critically stable in conventional applications. To improve stability, a modified β can be calculated from (13a) and (13b) to meet the constraints on GM_1 and GM_2 . However, as these constraints vary with f_r , selecting β for a specific f_r is not enough, its robustness against the variation of f_r , which is usually caused by the variation of L_g , must be taken into account.

According to (13a) and (13b), the curves of GM_1 and GM_2 with the increase of L_g are depicted in Fig. 5. Although the expressions of GM_2 vary with λ , their trends versus L_g are similar and, thus, can be represented by one curve. To cover all the three cases listed in Table I, $f_r > f_{\text{crit}}$ is chosen for $L_g = 0$, and it is also an usual situation in practice [6]–[8]. With the increase of L_g , the system moves from Case III into Case II and Case I successively, meanwhile, GM_1 increases and GM_2 decreases. The curves of GM_1 and GM_2 intersects at $f_r = f_{\text{crit}}$, which corresponds to a critical grid inductance $L_{g,\text{crit}}$. Letting $f_r = f_{\text{crit}}$ in (4), $L_{g,\text{crit}}$ can be derived as

$$L_{g,\text{crit}} = \frac{L_1 + L_2 - L_1 L_2 C (2\pi f_{\text{crit}})^2}{L_1 C (2\pi f_{\text{crit}})^2 - 1}. \quad (15)$$

Note that the GM constraints in Case III are exactly in contrary to those in Cases II, and these two cases are bounded by $f_r = f_{\text{crit}}$. If β is designed so that $\text{GM}_1 = \text{GM}_2 = 0$ dB for $f_r = f_{\text{crit}}$ ($L_g = L_{g,\text{crit}}$), the constraints on GM_1 and GM_2 will be satisfied for all the three cases, as shown in Fig. 5(a). Thus, the system will be stable irrespective of L_g . Substituting $L_g = L_{g,\text{crit}}$ into (13a), the value of β yielding $\text{GM}_1 = 0$ dB, which is denoted by β_{opt} , can be derived as

$$\beta_{\text{opt}} = \frac{L_1}{L_1 + L_2 + L_{g,\text{crit}}}. \quad (16)$$

According to (15) and (16), β_{opt} can be solely determined once the LCL filter parameters have been specified. Compared with the conventional $\beta = L_1/(L_1 + L_2 + L_g)$ in (6), β_{opt}

$$\text{GM}_2 = -20 \lg |T_{iL_2}(e^{j2\pi f_{\text{crit}} T_s})| = \begin{cases} 20 \lg \left| \frac{L_1 + L_2 + L_g}{K_p L_1} \cdot \frac{(K_{\text{d.crit}} - \beta K_p) \sin 0.5 \omega_r T_s}{\sin 0.5 \omega_r T_s - 0.5 \omega_r T_s \cos \omega_r T_s} \right|, & \lambda = 0.5 \\ 20 \lg \left| \frac{L_1 + L_2 + L_g}{K_p L_1} \cdot \frac{(K_{\text{d.crit}} - \beta K_p) \sin \omega_r T_s}{\sin \omega_r T_s - \omega_r T_s (2 \cos \omega_r T_s - 1)} \right|, & \lambda = 1 \end{cases} \quad (13b)$$

TABLE I
 GAIN MARGIN CONSTRAINTS IN THE CONTROL

	Case I	Case II	Case III
Resonance frequency	$f_r < f_{crit}$	$f_r < f_{crit}$	$f_r \geq f_{crit}$
Damping gain	$\beta K_p \leq K_{d,crit}$	$\beta K_p > K_{d,crit}$	$\beta K_p > 0$
Gain margin constraints	$GM_1 > 0$ dB	$GM_1 > 0$ dB, $GM_2 < 0$ dB.	$GM_1 < 0$ dB, $GM_2 > 0$ dB.

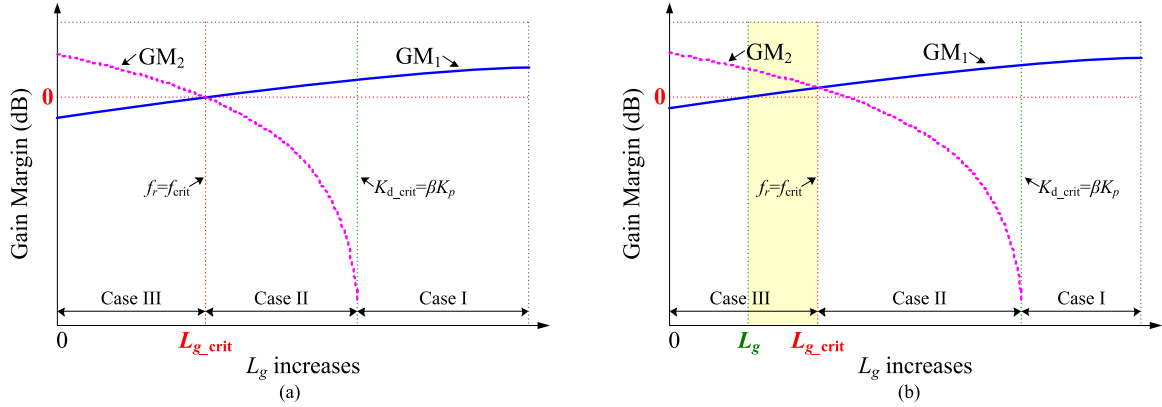
 Fig. 5. Curves of GM_1 and GM_2 with the increase of L_g . (a) $\beta = L_1/(L_1 + L_2 + L_{g,crit})$. (b) $\beta = L_1/(L_1 + L_2 + L_g)$.

replaces the uncertain L_g with the defined $L_{g,crit}$. The change seems minor, but its improvement on the system robustness is significant. For example, if $\beta = L_1/(L_1 + L_2 + L_g)$ is set for an initial L_g that is smaller $L_{g,crit}$, which implies $\beta > \beta_{opt}$, then with the increase of grid inductance, GM_1 gets larger than 0 dB, as shown in Fig. 5(b). This goes against the GM constraints at least in the range between the initial L_g and $L_{g,crit}$ (where $GM_1 < 0$ dB is required), shown as the shaded area in Fig. 5(b), thus leading to instability. Similar instability will arise in the case of $\beta < \beta_{opt}$, which thus comes to the conclusion that β_{opt} is the optimal split proportion.

Aside from the improvement, a special point needs to be concerned that at the particular $f_r = f_{crit}$ ($L_g = L_{g,crit}$), the system is critically stable due to $GM_1 = GM_2 = 0$ dB. In [34], the stability challenge is addressed by introducing a phase-lag compensator into the current regulator $G_i(z)$. This solution is proposed for the grid current control, unfortunately, it is found useless for the weighted average current control here. In the grid current control, the capacitor current active damping is extra introduced, and its damping performance is independent of $G_i(z)$. Thus, by modifying $G_i(z)$, the loop gain can be adjusted explicitly to ensure stability. However, in the weighted average current control, the capacitor current active damping is inherently existent, and its damping performance is related to $G_i(z)$. That means the outer current loop and the inner damping loop are interacted. Thus, it becomes inexplicit to adjust the loop gain by modifying $G_i(z)$. Recalling (9) and Fig. 4, it is observed that $G_i(z)$ exists in both the numerator and the denominator of $T_{iL2}(z)$, where the former refers to the one located in the outer current loop and the latter refers to the one located in

the inner damping loop. Particularly, at the resonance frequency f_r , i.e., $z = z_{1,2}$ [see (10)], the two $G_i(z)$ are cancelled out in $T_{iL2}(z_{1,2})$, as shown in (11), which means $T_{iL2}(z_{1,2})$ is independent of $G_i(z)$. Therefore, even if a phase-lag compensator is added to $G_i(z)$, $T_{iL2}(z_{1,2})$ will remain unchanged and yield $T_{iL2}(z_{1,2}) = -1$ for $L_g = L_{g,crit}$, implying a critically stable feature. In practice, this small imperfection at such a single point will not cause visible hazard. Moreover, it can be offset by the damping effect of the parasitic resistors in the filter and the grid, which will be discussed later in the next sections.

Another issue should be noted that, although the robust weighted average current control is proposed based on the equivalent dual-loop model, its implementation is still in the single-loop manner with the *LCCL* filter method shown in Fig. 1, except that β is replaced by β_{opt} . Thus, it remains the benefits of the conventional single-loop control.

IV. IMPROVED *LCCL* FILTER CONFIGURATION CONSIDERING THE NOMINAL CAPACITANCE

For implementation of the proposed robust weighted average current control, the capacitor of the *LCL* filter needs to be split with the proportion in (16), i.e., $C_1 = (1 - \beta_{opt})C$ and $C_2 = \beta_{opt}C$. Although simple, the calculated values of C_1 and C_2 may not be nominal capacitances. As a result, the actually used capacitances, which must be nominal values, may not match with the calculated (desired) values. This mismatch will cause the actual split proportion deviated from the desired β_{opt} , leading to less robustness. To overcome this drawback, multiple nominal capacitances can be connected in series or in parallel

to yield an actual capacitance that equals to the desired one. However, using multiple capacitances for a single filter is not convenient and cost-effective in practice. A practical application would expect to configure two capacitors of the same value, i.e., $C_1 = C_2$, which implies $\beta_{\text{opt}} = 0.5$.

Letting $\beta_{\text{opt}} = 0.5$ in (16) yields that $L_1 = L_2 + L_{g\text{-crit}}$, which upon substituted with (15), gives rise to

$$\frac{1}{2\pi\sqrt{L_1 C}} = \frac{f_{\text{crit}}}{\sqrt{2}} \Rightarrow L_1 = \frac{2}{(2\pi f_{\text{crit}})^2 C}. \quad (17)$$

According to (17), the requirement on β_{opt} is transferred to the requirement on the resonance frequency between L_1 and C . This can be regarded as an extra constraint on the design of the LCCL filter. Besides, there are other well-known constraints, i.e., the inverter-side current ripple is within 15–40% (peak-to-peak) of the rated current, the capacitive reactive power is less than 5% of the rated load, and the grid-side switching harmonic is less than 0.3% of the rated current [35]–[38]. For the single-phase inverter employing the unipolar sinusoidal PWM, the constraint on the inverter-side current ripple Δi_{L1} is expressed as

$$15\% \leq \frac{\Delta i_{L1}}{I_o} = \frac{V_{\text{in}}}{8L_1 f_{\text{sw}} I_o} \leq 40\% \quad (18)$$

where f_{sw} is the switching frequency, and $I_o = P_o/V_g$ is the rated output current, with P_o and V_g being the output power and the grid voltage (rms), respectively. From (18), the lower and upper limits on L_1 can be obtained, and they are further transferred to the limits on C by substituting (17) into (18) and manipulating, i.e.

$$\frac{15\% \cdot 16 f_{\text{sw}} I_o}{(2\pi f_{\text{crit}})^2 V_{\text{in}}} \leq C \leq \frac{40\% \cdot 16 f_{\text{sw}} I_o}{(2\pi f_{\text{crit}})^2 V_{\text{in}}}. \quad (19)$$

Except for (19), C is also limited by the reactive power drawn from the grid, i.e.

$$C \leq \frac{5\% P_o}{\omega_o V_g^2} \quad (20)$$

where $\omega_o = 2\pi f_o$ is the fundamental angular frequency.

According to (3), the grid-side switching harmonics are expressed as $|I_{L2}(j\omega_h)| = |G_{iL2}(j\omega_h)| \cdot |V_{\text{inv}}(j\omega_h)|$, where ω_h is the harmonic angular frequency and h is the harmonic order. Usually, the dominant harmonic with $\omega_h = 2\pi(2f_{\text{sw}} - f_o)$ is considered, whose harmonic voltage (rms) is $|V_{\text{inv}}(j\omega_h)| = 20\%V_{\text{in}}$ referring to [39]. Recalling $G_{iL2}(s)$ in (3) and assuming $L_g = 0$ (the worst case for harmonic attenuation), the required L_2 for meeting $|I_{L2}(j\omega_h)| \leq 0.3\%I_o$ is obtained as

$$L_2 \geq \frac{1}{\omega_h^2 L_1 C - 1} \left(L_1 + \frac{20\%V_{\text{in}}}{\omega_h 0.3\%I_o} \right). \quad (21)$$

Substituting (17) into (21) yields

$$L_2 \geq \frac{(2\pi f_{\text{crit}})^2}{2\omega_h^2 - (2\pi f_{\text{crit}})^2} \left(\frac{2}{(2\pi f_{\text{crit}})^2 C} + \frac{20\%V_{\text{in}}}{\omega_h 0.3\%I_o} \right). \quad (22)$$

According to (17), (22), and the system parameters listed in Table II, the curves of L_1 and L_2 as function of C are depicted in Figs. 6 and 7, respectively. Two typical λ , i.e., $\lambda = 0.5$ and $\lambda = 1$, are both considered here. In order to meet the constraint

TABLE II
PARAMETERS OF THE PROTOTYPE

System Parameters				
Input voltage V_{in}	360 V	Fundamental frequency f_o	50 Hz	
Grid voltage V_g	220 V	Switching frequency f_{sw}	10 kHz	
Output power P_o	6 kW	Sampling frequency f_s	20 kHz	
LCCL Filter Parameters				
Filter	Inverter-side inductor L_1	Filter capacitor C_1	Filter capacitor C_2	Grid-side inductor L_2
I (proposed)	485 μH	4.7 μF	4.7 μF	125 μH
II (conventional)	485 μH	2 μF	8 μF	125 μH

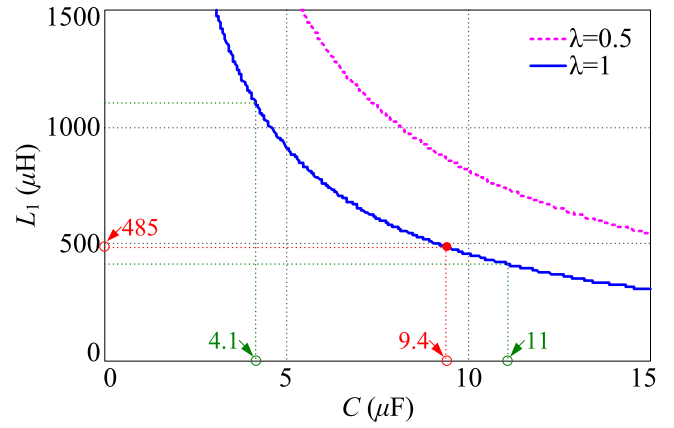

Fig. 6. Curve of L_1 as function of C .

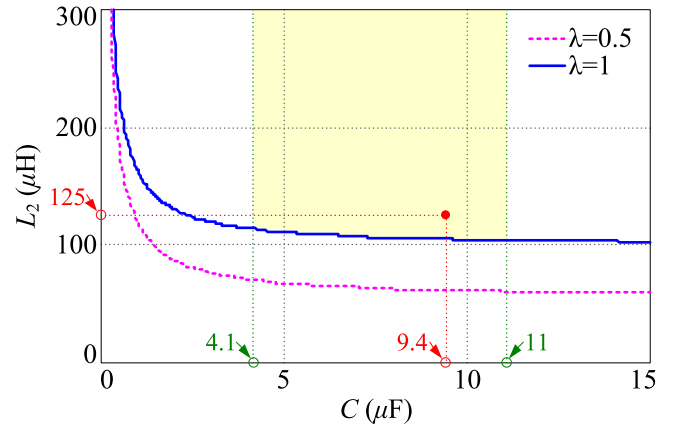

Fig. 7. Curve of L_2 as function of C .

in (17), the selected L_1 and C must be a point located exactly on the curve in Fig. 6. While in Fig. 7, the satisfactory L_2 and C is the region above the curve, shown as the shaded area (taking $\lambda = 1$ for example), whose lower limit is defined by (22). Therefore, selection of L_2 is much more flexible, but it is recommended to be close to the lower limit for the cost-effective purpose.

Taking the system parameters listed in Table II and $\lambda = 1$ as an instance, a three-step design procedure of the LCCL filter is presented as follows. As the capacitor is the component of most concern, it is designed at first.

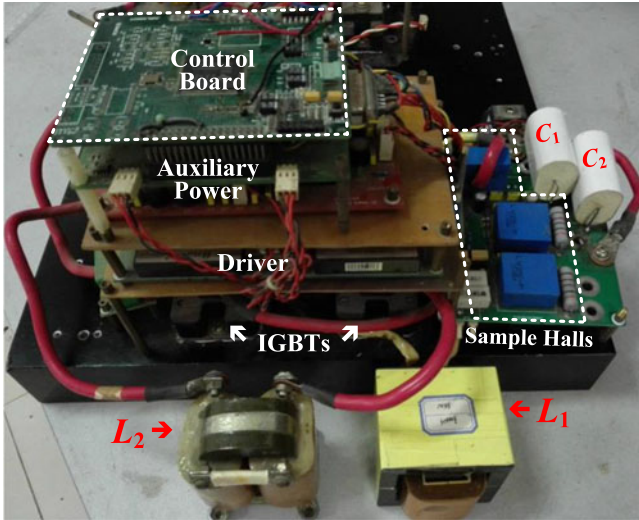

Fig. 8. Photograph of the single-phase grid-connected inverter prototype.

- 1) Determine the possible range of the capacitor, select a proper one and then split it. $4.1 \mu\text{F} \leq C \leq 11 \mu\text{F}$ and $C \leq 20 \mu\text{F}$ are obtained from (19) and (20), respectively. Thus, the former is taken as the possible range. As shown in (17) and Fig. 6, L_1 is inversely proportional to C . A relatively large C is suggested to lower L_1 , and it should be twice the nominal capacitance for convenience of splitting. Here, $C = 9.4 \mu\text{F}$ is selected and split into $C_1 = C_2 = 4.7 \mu\text{F}$, with a total reactive power of 2.4%.
- 2) Calculate L_1 according to (17). Substituting $C = 9.4 \mu\text{F}$ into (17) yields $L_1 = 485 \mu\text{H}$, whose location is identified in Fig. 6. Recalling (18), the consequent inverter-side current ripple can be calculated as 34%.
- 3) Select a proper L_2 from the satisfactory region in Fig. 7. With $C = 9.4 \mu\text{F}$, the lower limit of L_2 is obtained as $L_2 \geq 105 \mu\text{H}$ from (22). Here, $L_2 = 125 \mu\text{H}$ is selected with some margin being reserved, as shown in Fig. 7.

It is worth noting that the above design procedure is a step-by-step approach without any trial and error. Based on the selected filter parameters, the initial *LCL* resonance frequency under $L_g = 0$ is calculated as $f_r = 5.2 \text{ kHz}$ from (4), and the critical grid inductance obtained from (15) is $L_{g,\text{crit}} = 360 \mu\text{H}$, which certainly meets $L_1 = L_2 + L_{g,\text{crit}}$ as expected.

For $\lambda = 0.5$, the same design procedure can be applied, and it is not repeated. The design results are given as $L_1 = 495 \mu\text{H}$, $C_1 = C_2 = 8.2 \mu\text{F}$, and $L_2 = 80 \mu\text{H}$. Thus, the initial resonance frequency is 4.8 kHz, which is comparable to that in $\lambda = 1$.

V. EXPERIMENTAL VERIFICATION

A. Prototype Description

To verify the theoretical analysis, a 6-kW prototype of Fig. 1 was built and tested in the lab. Its photograph is given in Fig. 8. The single-phase inverter bridge was implemented using two insulated-gate bipolar transistor modules (CM100DY-24NF). These modules were driven by M57962L. The PCC voltage v'_g ,

which was used in the PLL, was sensed by a voltage hall (LV25-P). The weighted average current i_{WA} was sensed by a current hall (LA55-P). The measured signals were filtered by an *RC* low-pass filter with the time constant of $1 \mu\text{s}$, before they were sent to an extended 14-bit A/D converter (MAXIM-1324ECM). Finally, the outputs of the A/D converter were transmitted to a TI TMS320F2812 DSP for the controller process.

The system parameters, together with the *LCCL* filter parameters designed in Section IV, are given in Table II. The unipolar sinusoidal, dual-update PWM was mainly implemented due to its smaller time delay, and $f_s = 2f_{\text{sw}} = 20 \text{ kHz}$ was set. The inverter-side inductor L_1 conducted abundant high-frequency ripple current, and it was fabricated by two pairs of EE70/33/32 ferrite cores to lower the loss. The grid-side inductor L_2 conducted only the fundamental current, and it was fabricated by the silicon-steel core to reduce the cost. Film capacitors produced by EACO STH series [40] were adopted as the filter capacitors C_1 and C_2 . The current controller is designed for these system settings, and the system stability is examined against the varying grid inductance. Typically, L_g varying up to 10% per unit, which corresponds to 2.6 mH in the test system, is considered.

For the PR regulator adopted, its continuous transfer function is expressed as

$$G_i(s) = K_p + \frac{2K_r\omega_i s}{s^2 + 2\omega_i s + \omega_i^2} \quad (23)$$

where ω_i is the resonant cutoff frequency. In view of a typical $\pm 1\%$ variation of the fundamental frequency [16], $\omega_i = 1\% \cdot 2\pi f_o = \pi \text{ rad/s}$ is set. The proportional gain K_p is designed to achieve a target crossover frequency f_c with a phase margin of 45° , and the resonant gain K_r is tuned with its corner frequency being a decade below f_c [32]. In this way, $K_p = 0.07$ and $K_r = 10$ are chosen. For practical use, the PR regulator is decomposed into two simple integrators, where the direct integrator is discretized by the forward Euler and the feedback one is discretized by the backward Euler [41]. Thus, the discrete representation of $G_i(s)$ is obtained as

$$G_i(z) = K_p + \frac{2K_r\omega_i T_s(z-1)}{z^2 + z(\omega_o^2 T_s^2 + 2\omega_i T_s - 2) - 2\omega_i T_s + 1} \quad (24)$$

As discussed in previous sections, the split proportion β is the most important term that affects the system stability. To provide a comparative study, two β drawn in different design procedures are evaluated. One is the proposed $\beta_{\text{opt}} = L_1/(L_1 + L_2 + L_{g,\text{crit}})$, and it is specified to $\beta_{\text{opt}} = 0.5$ with the improved filter configuration in Section IV, whose corresponding *LCCL* filter is identified as Filter I in Table II. The other is the conventional $\beta = L_1/(L_1 + L_2 + L_g)$. Keeping the same filter inductances and considering an initial $L_g = 0$, $\beta = 485/(485 + 125) = 0.8$ is yielded from (6). For splitting, the filter capacitance is slightly adjusted to $C = 10 \mu\text{F}$, with $C_1 = (1 - \beta)C = 2 \mu\text{F}$ and $C_2 = \beta C = 8 \mu\text{F}$. This filter setting is identified as Filter II, as shown in Table II.

Recalling $T_{iL2}(z)$ in (9), the pole map of the closed-loop transfer function $T_{iL2}(z)/[1 + T_{iL2}(z)]$ is drawn in Fig. 9, with L_g varying up to 2.6 mH (the pairs of closed-loop poles

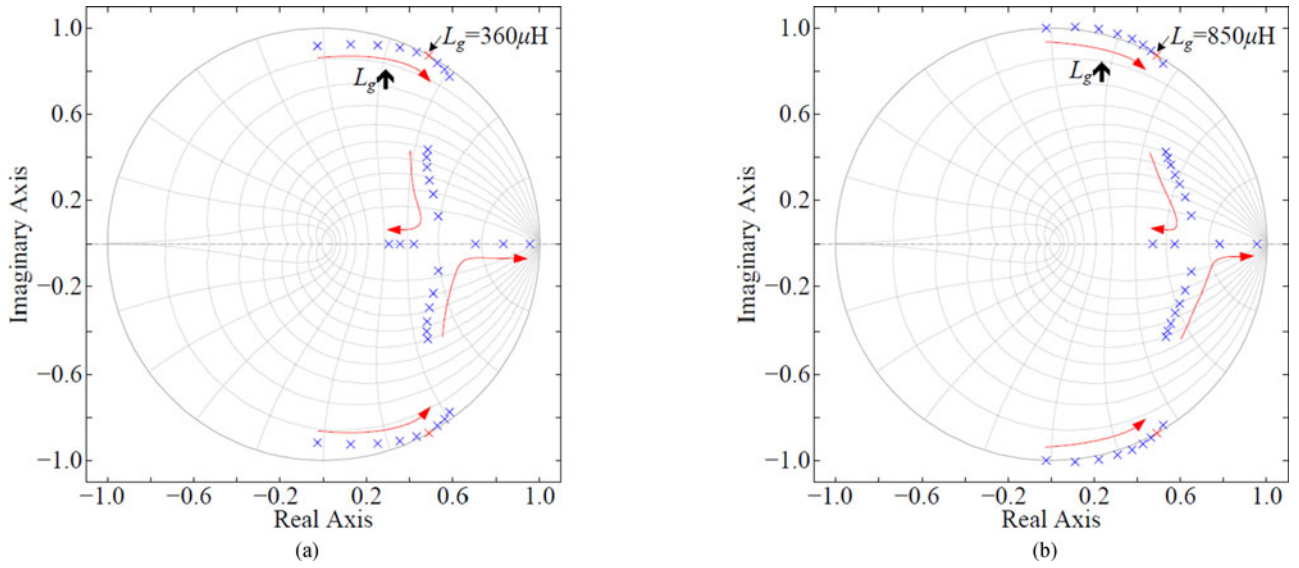

Fig. 9. Grid current closed-loop pole maps with L_g varying up to 2.6 mH. (a) $\beta = L_1/(L_1 + L_2 + L_{g,crit}) = 0.5$. (b) $\beta = L_1/(L_1 + L_2 + L_g) = 0.8$ (initialized with $L_g = 0$).

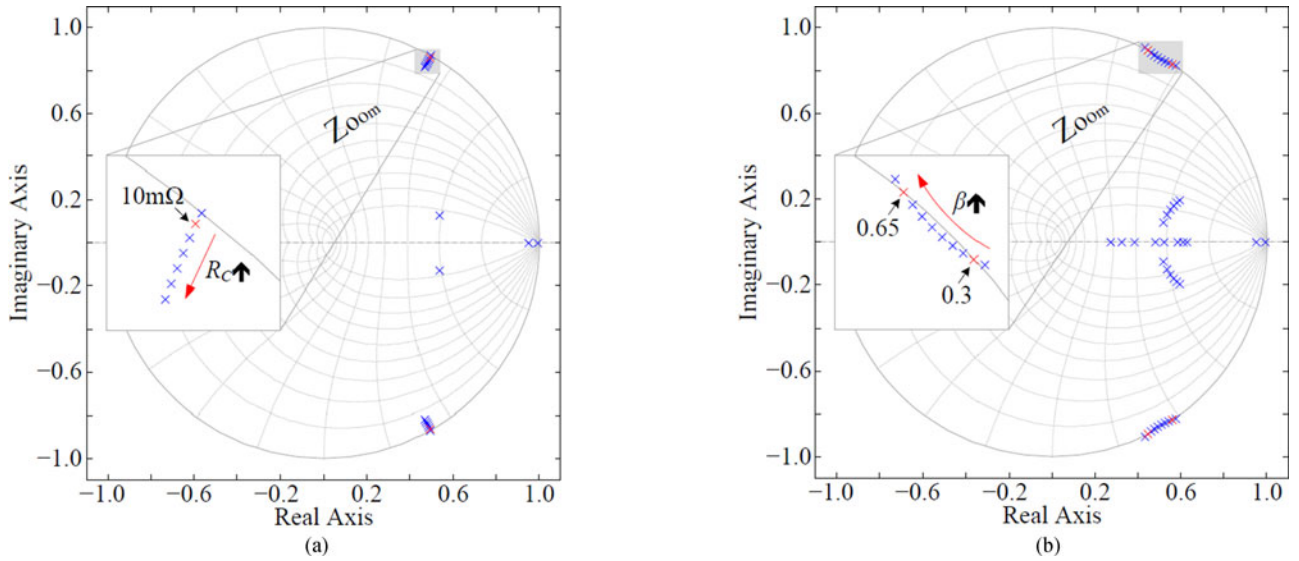

Fig. 10. Damping of the critically stable point at $L_g = L_{g,crit} = 360 \mu\text{H}$. (a) Effect of the capacitor ESR. (b) Effect of the capacitance deviation with $R_C = 10 \text{ m}\Omega$.

introduced by the PR regulator are not shown here since they vary little). As $T_{iL_2}(z)$ is the loop gain related to i_{L_2} , the closed-loop pole trajectory directly indicates the stability of grid current. With $\lambda = 1$, $f_{crit} = f_s/6$, and $L_{g,crit} = 360 \mu\text{H}$ can be obtained from (12) and (15), respectively. For $\beta = \beta_{opt} = 0.5$, as shown in Fig. 9(a), the resonant poles almost stay inside the unit circle, with only a critical point located exactly at the unit circle for $L_g = L_{g,crit} = 360 \mu\text{H}$ ($f_r = f_s/6$). While for $\beta = 0.8$, as shown in Fig. 9(b), the resonant poles start exactly at the unit circle and then move outside for $L_g < 850 \mu\text{H}$. Thus, the grid current is not only critically stable at the initial status, but turns to be unstable for a wide range of grid impedance. This is consistent with the analysis in Section III, and confirms that the proposed method is more robust.

As mentioned in Section III, the critically stable point at $L_g = 360 \mu\text{H}$ can be damped by the parasitic resistors in the filter and the grid. To illustrate this effect, the capacitor equivalent series resistor (ESR) R_C is taken as an instance, as shown in Fig. 10(a). With the increase of R_C , the resonant poles are shifted into the unit circle gradually. For the selected capacitor, $R_C = 10 \text{ m}\Omega$ is given in [40]. Its corresponding pole locations are $0.49 \pm j0.86$, whose distance from the origin is 0.99. This stability margin seems small, but its robustness is not trivial. As β is the most important term on stability, the pole movement against the variation of β , which is caused by the capacitance deviation, is studied here, as shown in Fig. 10(b). With $R_C = 10 \text{ m}\Omega$, the allowable range of β is 0.3–0.65, i.e., -40% – $+30\%$, which is much wider than the possible range of the capacitance

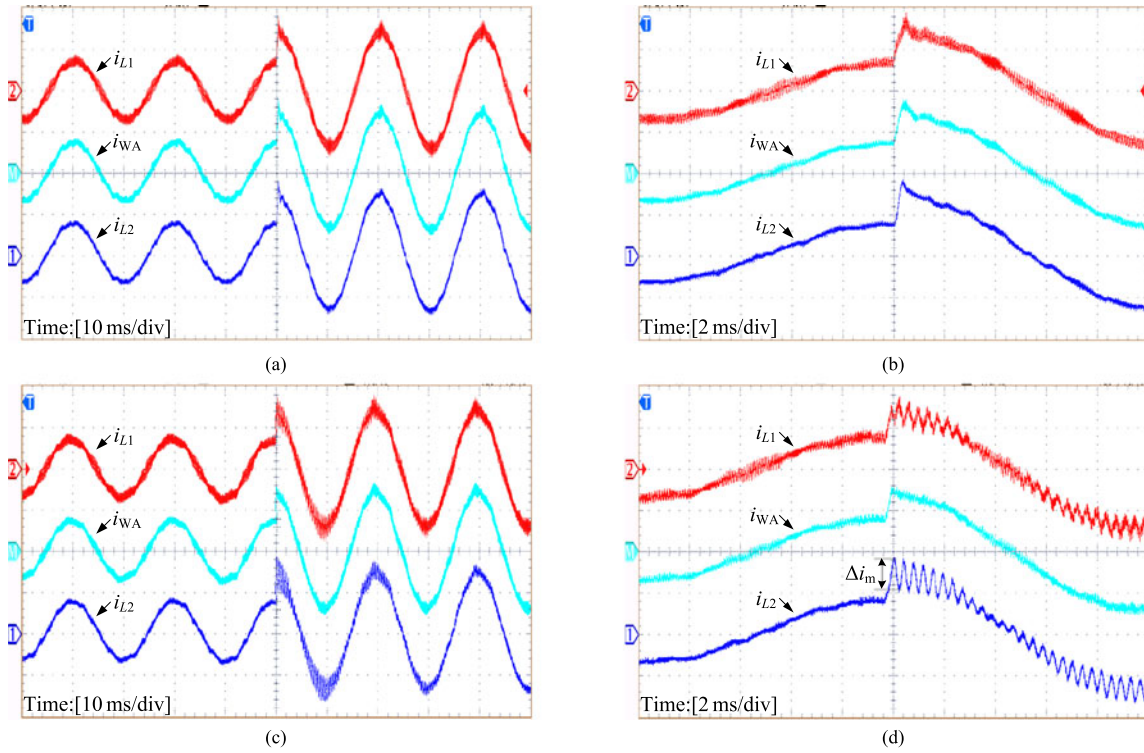

Fig. 11. Experimental results when the current reference steps from half to full loads at $L_g = 0$. (a) $\beta = L_1 / (L_1 + L_2 + L_{g,crit}) = 0.5$. (b) Zoom of (a). (c) $\beta = L_1 / (L_1 + L_2 + L_g) = 0.8$ (initialized with $L_g = 0$). (d) Zoom of (c). Current waveform scales: 30 A/div.

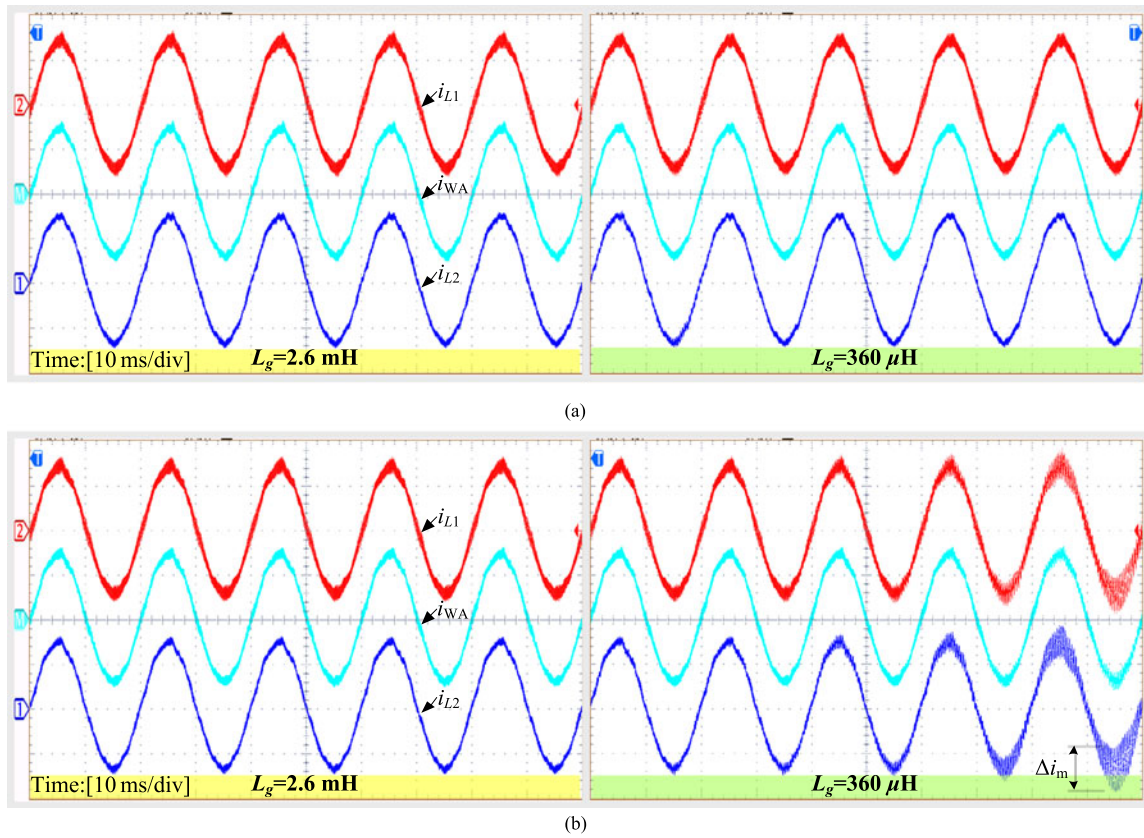

Fig. 12. Experimental results at full load under the grid impedance variation. (a) $\beta = L_1 / (L_1 + L_2 + L_{g,crit}) = 0.5$. (b) $\beta = L_1 / (L_1 + L_2 + L_g) = 0.8$ (initialized with $L_g = 0$). Current waveform scales: 30 A/div.

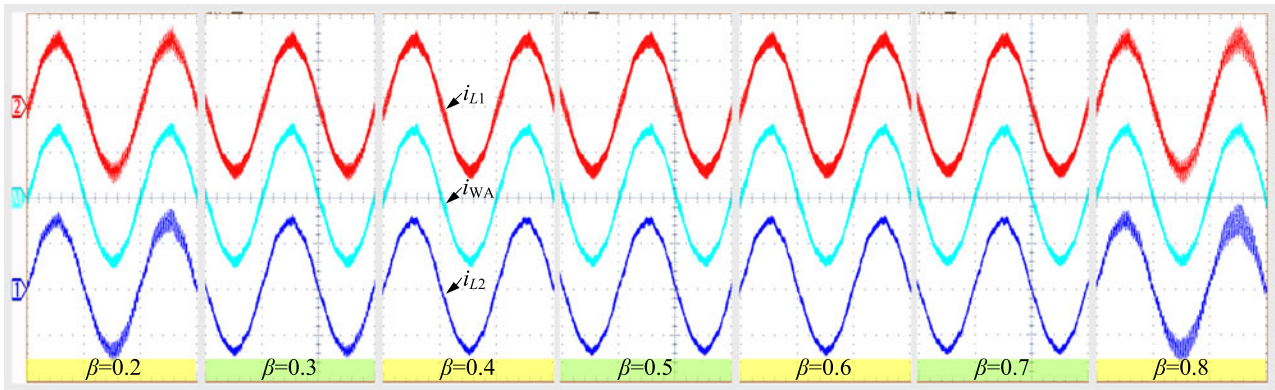

Fig. 13. Experimental results at $L_g = 360 \mu\text{H}$ under the capacitance deviation. Current waveform scales: 30 A/div, time scale: 10 ms/div.

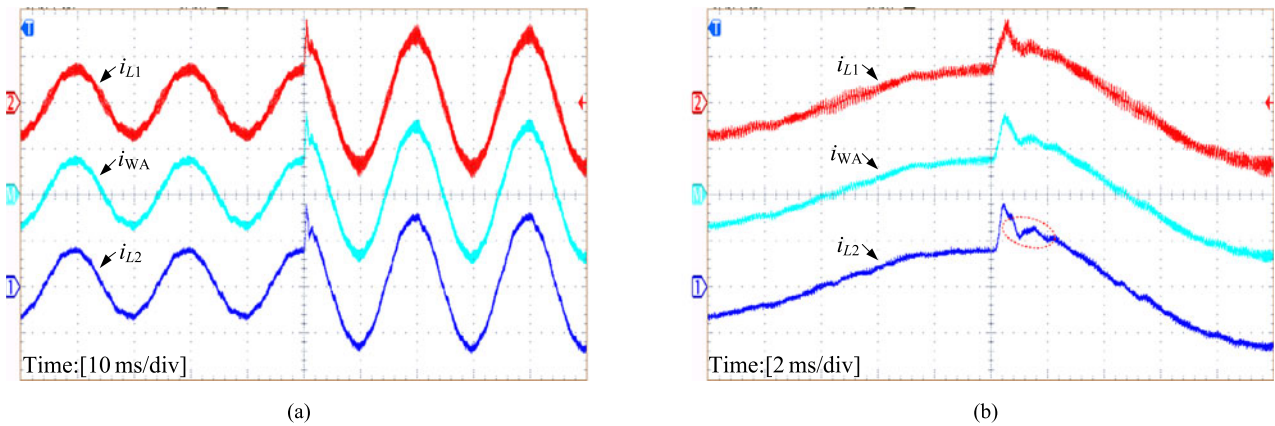

Fig. 14. Experimental results when the current reference steps from half to full loads at $L_g = 0$ for $\lambda = 0.5$ and $\beta = \beta_{\text{opt}} = 0.5$. (a) Full view. (b) Zoom of (a). Current waveform scales: 30 A/div.

deviation (usually $\pm 10\%$ [40]), implying a good robustness. In practice, the robustness is even better due to other resistors in the filter inductors and the grid.

B. Experimental Results

Referring to the design procedure developed above, experimental results of the proposed and conventional weighted average current control schemes were compared here. The inverter current i_{L1} , the grid current i_{L2} , and their weighted average value i_{WA} were all measured. Transient performances of the two control schemes were tested at first. Usually, the transient response against load change was concerned for a power converter. However, for the grid-connected inverter which injected current into the grid, there was no physical “load,” and its dynamics was evaluated by changing the current reference. Fig. 11 shows the experimental results when the current reference steps from half to full loads at $L_g = 0$. To achieve a detailed study, the experimental waveforms during the transition fundamental period are zoomed in, as shown in Fig. 11(b) and (d). It can be seen that satisfactory transient responses are performed in all the currents for $\beta = \beta_{\text{opt}} = 0.5$. With regard to i_{L2} , the percentage overshoot and the settle time are measured as 25% and 0.8 ms (5% tolerance), respectively, and the current ripple is 0.5 A, which is negligible. While for $\beta = 0.8$, quite different features are observed in i_{WA} and i_{L2} (i_{L1}). Despite that i_{WA}

exhibits satisfactory steady-state and dynamic performances, i_{L1} and i_{L2} are both critically stable. When the current reference steps upward, both i_{L1} and i_{L2} oscillate, and the oscillations decay sluggishly and last for over two fundamental periods. The maximum current ripple in i_{L2} , which is identified by Δi_m in Fig. 11(d), is measured as 22 A (peak-to-peak).

Fig. 12 shows the experimental results at full load under the grid impedance variation. Both $L_g = 360 \mu\text{H}$ (the critical grid inductance) and $L_g = 2.6 \text{ mH}$ are tested here. For $\beta = \beta_{\text{opt}} = 0.5$, as shown in Fig. 12(a), stable operations are retained for both grid conditions, with a negligible current ripple of 0.5 A in i_{L2} . However, for $\beta = 0.8$, as shown in Fig. 12(b), disastrous oscillations are triggered when $L_g = 360 \mu\text{H}$, and the maximum current ripple in i_{L2} is measured as 30 A. It can be found that the proposed method achieves a strong robustness, which is in agreement with the theoretical analysis in this paper.

For $L_g = 360 \mu\text{H}$, system performances under the capacitance deviation was intentionally investigated here. In this test, the capacitances C_1 and C_2 were adjusted so that β was varied in the range from 0.2 to 0.8 with a step of 0.1. Fig. 13 shows the corresponding experimental results at full load. It can be seen that severe oscillations arise for $\beta = 0.2$ and $\beta = 0.8$, while stable operations are retained for all the other β . The practically allowable range of β is wider than that in Fig. 10(b), since there are extra resistors in the filter inductors and the grid except for the capacitor ESR.

The above results had verified the effectiveness of the proposed method under the dual-update mode, i.e., $\lambda = 1$. To show its generality, the single-update mode with $\lambda = 0.5$ was further tested. In this case, $f_s = f_{sw} = 10$ kHz was set, and the LCCL filter designed in Section IV was adopted. Fig. 14 shows the experimental results when the current reference steps from half to full loads at $L_g = 0$. Stable operation is retained as expected. The percentage overshoot and the settle time in i_{L2} are measured as 25% and 2 ms, respectively. Compared with $\lambda = 1$, the dynamic response becomes slower, since the control bandwidth is reduced by the increased time delay. The other results under different grid conditions are similar to those in $\lambda = 1$, thus they are not repeated here. The experimental results confirm that the proposed method is effective irrespective of the time delay.

VI. CONCLUSION

This paper studies the robust single-loop current control scheme for the LCL-type grid-connected inverter. The weighted average current control implemented with the LCCL filter method is in focus, and it is proved to experience a poor robustness against the grid impedance variation and have weak stability (critically stable) in the grid current. To address these limitations, the single-loop weighted average current control is equivalently transformed into the dual-loop grid current control with an inherent capacitor current active damping. This inherent damping is determined by the capacitor split proportion. A design procedure is, thus, presented to select an optimal split proportion, so that a robust damping performance can be achieved by the inherent damping. Furthermore, with an improved LCCL filter configuration, the optimal split proportion is specified to 0.5. Thus, two equal nominal capacitances can be used for the split capacitors, which are very convenient for the practical implementation. Compared with the conventional single-loop control schemes, the proposed weighted average current control improves the system robustness without any extra cost, and it is applicable to the systems with different time delays. The effectiveness of the proposed method is verified by experimental results in a single-phase grid-connected inverter.

REFERENCES

- [1] J. Dannehl, F. W. Fuchs, S. Hansen, and P. B. Thøgersen, "Investigation of active damping approaches for PI-based current control of grid-connected pulse width modulation converters with LCL filters," *IEEE Trans. Ind. Appl.*, vol. 46, no. 4, pp. 1509–1517, Jul./Aug. 2010.
- [2] J. He and Y. W. Li, "Generalized closed-loop control schemes with embedded virtual impedances for voltage source converters with LC or LCL filters," *IEEE Trans. Power Electron.*, vol. 27, no. 4, pp. 1850–1861, Apr. 2012.
- [3] X. Ruan, X. Wang, D. Pan, D. Yang, W. Li, and C. Bao, *Control Techniques for LCL-Type Grid-Connected Inverters*. Singapore: Springer, 2017.
- [4] D. Pan, X. Ruan, and X. Wang, "Direct realization of digital differentiators in discrete domain for active damping of LCL-type grid-connected inverter," *IEEE Trans. Power Electron.*, to be published.
- [5] Y. Tang, P. C. Loh, P. Wang, F. H. Choo, F. Gao, and F. Blaabjerg, "Generalized design of high performance shunt active power filter with output LCL filter," *IEEE Trans. Ind. Electron.*, vol. 59, no. 3, pp. 1443–1452, Mar. 2012.
- [6] X. Wang, F. Blaabjerg, and P. C. Loh, "Virtual RC damping of LCL-filtered voltage source converters with extended selective harmonic compensation," *IEEE Trans. Power Electron.*, vol. 30, no. 9, pp. 4726–4737, Sep. 2015.
- [7] X. Wang, F. Blaabjerg, and P. C. Loh, "Grid-current-feedback active damping for LCL resonance in grid-connected voltage source converters," *IEEE Trans. Power Electron.*, vol. 31, no. 1, pp. 213–223, Jan. 2016.
- [8] Z. Xin, P. C. Loh, X. Wang, F. Blaabjerg, and Y. Tang, "Highly accurate derivatives for LCL-filtered grid converter with capacitor voltage active damping," *IEEE Trans. Power Electron.*, vol. 31, no. 5, pp. 3612–3625, May 2016.
- [9] C. Zou, B. Liu, S. Duan, and R. Li, "Influence of delay on system stability and delay optimization of grid-connected inverters with LCL filter," *IEEE Trans. Ind. Informat.*, vol. 10, no. 3, pp. 1775–1784, Aug. 2014.
- [10] J. Wang, J. D. Yan, L. Jiang, and J. Zou, "Delay-dependent stability of single-loop controlled grid-connected inverters with LCL filters," *IEEE Trans. Power Electron.*, vol. 31, no. 1, pp. 743–757, Jan. 2016.
- [11] S. G. Parker, B. P. McGrath, and D. G. Holmes, "Regions of active damping control for LCL filters," *IEEE Trans. Ind. Appl.*, vol. 50, no. 1, pp. 424–432, Jan./Feb. 2014.
- [12] J. Wang, J. D. Yan, and L. Jiang, "Pseudo-derivative-feedback current control for three-phase grid-connected inverters with LCL filters," *IEEE Trans. Power Electron.*, vol. 31, no. 5, pp. 3898–3912, May 2016.
- [13] X. Wang, F. Blaabjerg, and P. C. Loh, "Passivity-based stability analysis and damping injection for multi-paralleled voltage source converters with LCL filters," *IEEE Trans. Power Electron.*, vol. 32, no. 11, pp. 8922–8935, Nov. 2017.
- [14] M. Huang, X. Wang, P. C. Loh, and F. Blaabjerg, "LLCL-filtered grid converter with improved stability and robustness," *IEEE Trans. Power Electron.*, vol. 31, no. 5, pp. 3958–3967, May 2016.
- [15] T.-F. Wu, M. Misra, L.-C. Lin, and C.-W. Hsu, "An improved resonant frequency based systematic LCL filter design method for grid-connected inverter," *IEEE Trans. Ind. Electron.*, vol. 64, no. 8, pp. 6412–6421, Aug. 2017.
- [16] M. Liserre, R. Teodorescu, and F. Blaabjerg, "Stability of photovoltaic and wind turbine grid-connected inverters for a large set of grid impedance values," *IEEE Trans. Power Electron.*, vol. 21, no. 1, pp. 263–272, Jan. 2006.
- [17] V. Miskovic, V. Blasko, T. M. Jahns, A. H. C. Smith, and C. Romenesko, "Observer-based active damping of LCL resonance in grid-connected voltage source converters," *IEEE Trans. Ind. Appl.*, vol. 50, no. 1, pp. 424–432, Jan./Feb. 2014.
- [18] D. Pan, X. Ruan, C. Bao, W. Li, and X. Wang, "Capacitor-current-feedback active damping with reduced computation delay for improving robustness of LCL-type grid-connected inverter," *IEEE Trans. Power Electron.*, vol. 29, no. 7, pp. 3414–3427, Jul. 2014.
- [19] D. Yang, X. Ruan, and H. Wu, "A real-time computation method with dual sampling mode to improve the current control performance of the LCL-type grid-connected inverter," *IEEE Trans. Ind. Electron.*, vol. 62, no. 7, pp. 4563–4572, Jul. 2015.
- [20] X. Li, J. Fang, Y. Tang, X. Wu, and Y. Geng, "Capacitor voltage feed-forward with full delay compensation to improve weak grids adaptability of LCL-filtered grid-connected converters for distributed generation systems," *IEEE Trans. Power Electron.*, vol. 33, no. 1, pp. 749–764, Jan. 2018.
- [21] K. Jalili and S. Bernet, "Design of LCL filters of active-front-end two-level voltage-source converters," *IEEE Trans. Ind. Electron.*, vol. 56, no. 5, pp. 1674–1689, May 2009.
- [22] X. Li, X. Wu, Y. Geng, X. Yuan, C. Xia, and X. Zhang, "Wide damping region for LCL-type grid-connected inverter with an improved capacitor-current-feedback method," *IEEE Trans. Power Electron.*, vol. 30, no. 9, pp. 5247–5259, Sep. 2015.
- [23] C. Chen, J. Xiong, Z. Wan, J. Lei, and K. Zhang, "A time delay compensation method based on area equivalence for active damping of an LCL-type converter," *IEEE Trans. Power Electron.*, vol. 32, no. 1, pp. 762–772, Jan. 2017.
- [24] Z. Xin, X. Wang, P. C. Loh, and F. Blaabjerg, "Grid-current-feedback control for LCL-filtered grid converters with enhanced stability," *IEEE Trans. Power Electron.*, vol. 32, no. 4, pp. 3216–3228, Apr. 2017.
- [25] M. Lu, X. Wang, P. C. Loh, F. Blaabjerg, and T. Dragicevic, "Graphical evaluation of time-delay compensation techniques for digitally-controlled converters," *IEEE Trans. Power Electron.*, vol. 33, no. 3, pp. 2601–2614, Mar. 2018.
- [26] G. Shen, D. Xu, L. Cao, and X. Zhu, "An improved control strategy for grid-connected voltage source inverters with an LCL filter," *IEEE Trans. Power Electron.*, vol. 23, no. 4, pp. 1899–1906, Jul. 2008.
- [27] G. Shen, X. Zhu, J. Zhang, and D. Xu, "A new feedback method for PR current control of LCL-filter-based grid-connected inverter," *IEEE Trans. Ind. Electron.*, vol. 57, no. 6, pp. 2033–2041, Jun. 2010.

- [28] N. He, D. Xu, Y. Zhu, J. Zhang, G. Shen, Y. Zhang, J. Ma, and C. Liu, "Weighted average current control in a three-phase grid inverter with an *LCL* filter," *IEEE Trans. Power Electron.*, vol. 28, no. 6, pp. 2785–2797, Jun. 2013.
- [29] J. He, Y. W. Li, D. Xu, X. Liang, B. Liang, and C. Wang, "Deadbeat weighted average current control with corrective feed-forward compensation for microgrid converters with nonstandard *LCL* filter," *IEEE Trans. Power Electron.*, vol. 32, no. 4, pp. 2661–2674, Apr. 2017.
- [30] D. Pan, X. Ruan, X. Wang, H. Yu, and Z. Xing, "Analysis and design of current control schemes for *LCL*-type grid-connected inverter based on a general mathematical model," *IEEE Trans. Power Electron.*, vol. 32, no. 6, pp. 4395–4410, Jun. 2017.
- [31] Y. Han, Z. Li, P. Yang, C. Wang, L. Xu, and J. M. Guerrero, "Analysis and design of improved weighted average current control strategy for *LCL*-type grid-connected inverters," *IEEE Trans. Energy Convers.*, vol. 32, no. 3, pp. 941–952, Sep. 2017.
- [32] D. G. Holmes, T. A. Lipo, P. McGrath, and W. Y. Kong, "Optimized design of stationary frame three phase AC current regulators," *IEEE Trans. Power Electron.*, vol. 24, no. 11, pp. 2417–2426, Nov. 2009.
- [33] L. Harnefors, X. Wang, A. G. Yepes, and F. Blaabjerg, "Passivity-based stability assessment of grid-connected VSCs—An overview," *IEEE J. Emerg. Sel. Topics Power Electron.*, vol. 4, no. 1, pp. 116–125, Mar. 2016.
- [34] D. Pan, X. Ruan, C. Bao, W. Li, and X. Wang, "Optimized controller design for *LCL*-type grid-connected inverter to achieve high robustness against grid-impedance variation," *IEEE Trans. Ind. Electron.*, vol. 62, no. 3, pp. 1537–1547, Mar. 2015.
- [35] W. Wu, Y. He, and F. Blaabjerg, "An *LLCL* power filter for single-phase grid-tied inverter," *IEEE Trans. Power Electron.*, vol. 27, no. 2, pp. 782–789, Feb. 2012.
- [36] D. Pan, X. Ruan, C. Bao, W. Li, and X. Wang, "Magnetic integration of the *LCL* filter in grid-connected inverters," *IEEE Trans. Power Electron.*, vol. 29, no. 4, pp. 1573–1578, Apr. 2014.
- [37] Y. Tang, W. Yao, P. C. Loh, and F. Blaabjerg, "Design of *LCL* filters with *LCL* resonance frequencies beyond the Nyquist frequency for grid-connected converters," *IEEE J. Emerg. Sel. Topics Power Electron.*, vol. 4, no. 1, pp. 3–14, Mar. 2016.
- [38] R. N. Beres, X. Wang, F. Blaabjerg, M. Liserre, and C. L. Bak, "Optimal design of high-order passive-damped filters for grid-connected applications," *IEEE Trans. Power Electron.*, vol. 31, no. 3, pp. 2083–2098, Mar. 2016.
- [39] D. G. Holmes and T. A. Lipo, *Pulse Width Modulation for Power Converters: Principles and Practice*. New York, NY, USA: Wiley, 2003.
- [40] EACO Capacitor, EACO Capacitor, Inc. [Online]. Available: <http://www.eaco.com/a/EN/Product/General/>
- [41] A. G. Yepes, F. D. Freijedo, J. D. Gandoy, Ó. López, J. Malvar, and P. F. Comesaña, "Effects of discretization methods on the performance of resonant controllers," *IEEE Trans. Power Electron.*, vol. 25, no. 7, pp. 1692–1712, Jul. 2010.



Donghua Pan (S'12–M'15) was born in Hubei Province, China, in 1987. He received the B.S. and Ph.D. degrees in electrical engineering from the Huazhong University of Science and Technology, Wuhan, China, in 2010 and 2015, respectively.

From July 2015 to August 2017, he was a Research Engineer with Suzhou Inovance Technology Co., Ltd., Suzhou, China. Since September 2017, he has been with Aalborg University, Aalborg, Denmark, where he is currently a Postdoctoral Fellow with the Department of Energy Technology. His

research interests include magnetic integration technique and renewable energy generation system.



Xinbo Ruan (M'97–SM'02–F'16) was born in Hubei Province, China, in 1970. He received the B.S. and Ph.D. degrees in electrical engineering from the Nanjing University of Aeronautics and Astronautics (NUAA), Nanjing, China, in 1991 and 1996, respectively.

In 1996, he joined the Faculty of Electrical Engineering Teaching and Research Division, NUAA, where he became a Professor with the College of Automation Engineering in 2002 and has been engaged in teaching and research in the field of power electronics. From August to October 2007, he was a Research Fellow with the Department of Electronic and Information Engineering, Hong Kong Polytechnic University, Hong Kong, China. From 2008 to 2011, he was also with the School of Electrical and Electronic Engineering, Huazhong University of Science and Technology, Wuhan, China. He is a Guest Professor with Beijing Jiaotong University, Beijing, China, with the Hefei University of Technology, Hefei, China, and also with Wuhan University, Wuhan. He has authored or coauthored nine books and more than 200 technical papers published in journals and conferences. His main research interests include soft-switching dc–dc converters, soft-switching inverters, power factor correction converters, modeling the converters, power electronics system integration, and renewable energy generation system.

Dr. Ruan was the recipient of the Delta Scholarship by the Delta Environment and Education Fund in 2003 and the Special Appointed Professor of the Chang Jiang Scholars Program by the Ministry of Education, China, in 2007. From 2005 to 2013, he served as the Vice President of the China Power Supply Society, and from 2014 to 2016, he served as the Vice Chair of the Technical Committee on Renewable Energy Systems within the IEEE Industrial Electronics Society. He is currently an Associate Editor for the IEEE TRANSACTIONS ON INDUSTRIAL ELECTRONICS, IEEE JOURNAL OF EMERGING AND SELECTED TOPICS IN POWER ELECTRONICS, IEEE TRANSACTIONS ON POWER ELECTRONICS, and IEEE TRANSACTIONS ON CIRCUITS AND SYSTEMS—II: EXPRESS BRIEFS.



Xiongfei Wang (S'10–M'13–SM'17) received the B.S. degree in electrical engineering from Yanshan University, Qinhuangdao, China, in 2006, the M.S. degree in electrical engineering from the Harbin Institute of Technology, Harbin, China, in 2008, and the Ph.D. degree in energy technology from Aalborg University, Aalborg, Denmark, in 2013.

Since 2009, he has been with Aalborg University, where he is currently an Associate Professor with the Department of Energy Technology. His research interests include modeling and control of grid-connected converters, harmonics analysis and control, passive and active filters, and stability of power electronic based power systems.

Dr. Wang serves as an Associate Editor for the IEEE TRANSACTIONS ON POWER ELECTRONICS, the IEEE TRANSACTIONS ON INDUSTRY APPLICATIONS, and the IEEE JOURNAL OF EMERGING AND SELECTED TOPICS IN POWER ELECTRONICS. He is also the Guest Editor for the Special Issue "*Grid-Connected Power Electronics Systems: Stability, Power Quality, and Protection*" in the IEEE TRANSACTIONS ON INDUSTRY APPLICATIONS. He was the recipient of the second prize paper award and the outstanding reviewer award of IEEE TRANSACTIONS ON POWER ELECTRONICS in 2014 and 2017, respectively, the second prize paper award of IEEE TRANSACTIONS ON INDUSTRY APPLICATIONS in 2017, and the best paper awards at IEEE PEDG 2016 and IEEE PES GM 2017.



Frede Blaabjerg (S'86–M'88–SM'97–F'03) received the Ph.D. degree in electrical engineering from Aalborg University, Aalborg, Denmark, in 1995.

From 1987 to 1988, he was with ABB-Scandia, Randers, Denmark. He became an Assistant Professor in 1992, an Associate Professor in 1996, and a Full Professor of power electronics and drives in 1998. In 2017, he became a Villum Investigator. He has authored or coauthored more than 500 journal papers in the fields of power electronics and its applications.

He has coauthored two monographs and is the Editor of six books in power electronics and its applications. His current research interests include power electronics and its applications, such as in wind turbines, photovoltaic systems, reliability, harmonics, and adjustable speed drives.

Dr. Blaabjerg was the recipient of 24 IEEE Prize Paper Awards, the IEEE PELS Distinguished Service Award in 2009, the EPE-PEMC Council Award in 2010, the IEEE William E. Newell Power Electronics Award 2014, and the Villum Kann Rasmussen Research Award 2014. He was the Editor-in-Chief of the IEEE TRANSACTIONS ON POWER ELECTRONICS from 2006 to 2012. He has been the Distinguished Lecturer for the IEEE Power Electronics Society from 2005 to 2007 and for the IEEE Industry Applications Society from 2010 to 2011 as well as from 2017 to 2018. He is nominated in 2014, 2015, 2016, and 2017 by Thomson Reuters to be between the most 250 cited researchers in Engineering in the world. In 2017, he became *Honoris Causa* at the University Politehnica Timisoara, Romania.

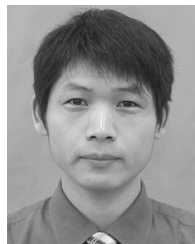

Xuehua Wang (M'12) was born in Hubei Province, China, in 1978. He received the B.S. degree in electrical engineering from the Nanjing University of Technology, Nanjing, China, in 2001, and the M.S. and Ph.D. degrees in electrical engineering from the Nanjing University of Aeronautics and Astronautics, Nanjing, in 2004 and 2008, respectively.

He is currently an Associate Professor with the School of Electrical and Electronic Engineering, Huazhong University of Science and Technology, Wuhan, China. His main research interests include multilevel inverter and renewable energy generation system.



Qingfeng Zhou (S'17) was born in Anhui Province, China, in 1993. He received the B.S. degree in electrical and electronic engineering in 2015 from the Huazhong University of Science and Technology, Wuhan, China, where he is currently working toward the M.S. degree in electrical engineering.

His research interests include digital control technique and renewable energy generation system.