

# DC Microgrids—Part II: A Review of Power Architectures, Applications, and Standardization Issues

Tomislav Dragičević, *Member, IEEE*, Xiaonan Lu, *Member, IEEE*, Juan C. Vasquez, *Senior Member, IEEE*, and Josep M. Guerrero, *Fellow, IEEE*

**Abstract**—DC microgrids (MGs) have been gaining a continually increasing interest over the past couple of years both in academia and industry. The advantages of dc distribution when compared to its ac counterpart are well known. The most important ones include higher reliability and efficiency, simpler control and natural interface with renewable energy sources, and electronic loads and energy storage systems. With rapid emergence of these components in modern power systems, the importance of dc in today's society is gradually being brought to a whole new level. A broad class of traditional dc distribution applications, such as traction, telecom, vehicular, and distributed power systems can be classified under dc MG framework and ongoing development, and expansion of the field is largely influenced by concepts used over there. This paper aims first to shed light on the practical design aspects of dc MG technology concerning typical power hardware topologies and their suitability for different emerging smart grid applications. Then, an overview of the state of the art in dc MG protection and grounding is provided. Owing to the fact that there is no zero-current crossing, an arc that appears upon breaking dc current cannot be extinguished naturally, making the protection of dc MGs a challenging problem. In relation with this, a comprehensive overview of protection schemes, which discusses both design of practical protective devices and their integration into overall protection systems, is provided. Closely coupled with protection, conflicting grounding objectives, e.g., minimization of stray current and common-mode voltage, are explained and several practical solutions are presented. Also, standardization efforts for dc systems are addressed. Finally, concluding remarks and important future research directions are pointed out.

**Index Terms**—DC microgrid (MG), power architectures, protection and grounding, standardization.

## I. INTRODUCTION

**P**ROLIFERATION of renewable energy sources (RES), together with ever more electronic loads and electric vehicles (EVs) in modern power networks has prompted an idea of considering the application of low-voltage dc distribution to areas far beyond the traditional dc distributed power systems (DPSs) [1]–[10], or power supplies for telecom stations

[11]–[13], data centers [14], [15], and vehicular electric power systems [16], [17]. Accompanied with technological advancements in power electronics and improvements in computational power of real-time controllers, dc systems of today are capable of achieving much broader functions than simple voltage regulation. Hence, they are becoming an increasingly popular solution for many types of residential and industrial applications, such as dc-powered homes [18]–[22], fast EV charging stations [23]–[29], hybrid energy storage systems (ESSs) [30]–[36], and renewable energy parks [37]–[43].

With regard to traditional ac, this kind of distribution has proved to offer more efficient and reliable energy transfer (see [44] for efficiency comparison of various architectures used in data centers). Calling on to this and other benefits, such as circumvention of problems with harmonics, unbalances, synchronization, and reactive power flows, different types of dc power distribution systems are experiencing more and more widespread use. Since extensive low- and medium-voltage dc distribution network infrastructure still does not exist, individual dc systems are nowadays either operated autonomously or connected to ac utility mains. Therefore, it is convenient to classify them as dc microgrids (MGs) [19]. This research topic has recently spurred a great amount of interest in research community [20], [45]–[55]. However, although dc MG appears to be a novel technology, it is essentially stemming from a hybrid mixture of several existing and ongoing research fields; one group being already mentioned traditional dc applications and the other being the ac MGs area.

MG concept was originally proposed in 2002, as a building block of future low-voltage distribution systems which were experiencing revolutionary changes at the time due to market liberalization and introduction of distributed generation (DG) [56], [57]. It was based on the idea of aggregating number of microsources and loads into one unique entity, which could be interpreted as a single dispatchable prosumer from the overhead power system viewpoint. AC MG research has been very dynamic over the course of following decade for MGs have soon after their introduction been recognized as a key element for integrating DG and storage, while allowing power independence from utility mains at the same time. From power electronics standing point, the roots of their development stem from control of paralleled inverters in uninterruptible power supplies (UPSs) [58]–[62].

Simultaneously with the fast development in ac MG arena, Ito *et al.* reported one of the first dc MG experimental prototypes

Manuscript received March 27, 2015; revised June 14, 2015; accepted July 28, 2015. Date of publication August 4, 2015; date of current version December 10, 2015. The work of X. Lu was supported by the U.S. Department of Energy (DOE) Office of Electricity Delivery and Energy Reliability. Recommended for publication by Associate Editor T.-F. Wu.

T. Dragičević, J. C. Vasquez, and J. M. Guerrero are with the Department of Energy Technology, Aalborg University, Aalborg 9220, Denmark (e-mail: tdr@et.aau.dk; juq@et.aau.dk; joz@et.aau.dk).

X. Lu is with the Energy Systems Division, Argonne National Laboratory, Lemont, IL 60439 USA (e-mail: xlu@anl.gov).

Color versions of one or more of the figures in this paper are available online at <http://ieeexplore.ieee.org>.

Digital Object Identifier 10.1109/TPEL.2015.2464277

of 10 kW in 2004, claiming for simpler control, while superior efficiency and reliability with regard to its ac counterpart [63].

Later on, several works followed up on it and demonstrated usage of flexible dc MGs for telecom systems [64], distributed renewable and storage plants [65], data centers [66], and residential households [67]. In the next years, accompanied by the rapid emergence of consumer electronics, integration of ever more RESs, and expansion of EV market with associated charging infrastructure, dc MGs have firmly established as a research field itself.

Driven by practical requirements of specific dc MG applications, a number of hardware topologies have been proposed. Principal criteria in that sense were control flexibility, robustness, and reliability. As they are often opposed to each other, different tradeoffs need to be taken into account before deciding the most suitable configuration for a given application. For its extreme robustness, direct connection of the battery stack to the common dc bus has been historically a popular structure for practical industrial applications. Some typical examples are power supplies for remote telecom stations [68] and rural-based households [69]. Due to high capacitance of the battery stack, dynamic stability of these kinds of systems is inherently assured [70]. Therefore, control design of converters that are used to interface different sources is not a critical issue from the bandwidth point of view, and thus, standardized components available in the market can be readily used. On the other hand, by interconnecting battery through power electronics converter interface, flexibility of the system is greatly increased since the voltage can then be actively regulated, rather than leaving it dependent on the battery operating conditions. Picking up on this basic structure, a number of alternatives have been proposed, including bipolar type dc bus [20], SST-enabled dc MGs [51], [71], [72], redundant dc bus structures [54], [73], and multiple dc MG clusters [19], [74].

For safe and reliable operation of dc MG, a well-functioning protection system is instrumental in any topology. Its principal objective is to minimize the propagation of disturbances by detecting and isolating faults within the minimum time frame [75], [76]. Protection of dc systems is in general a challenging task due to difficulties in extinguishing arc, which on the contrary happens naturally in ac systems. Accurate short-circuit current calculation and fault detection are the most important prerequisites for the good design of protection system [45].

Moreover, an assessment of the influence of realistic protection devices and grounding methods on the total system performance becomes critical when deploying a protection system in real-world environment. Up to this point, protection of dc MGs was designed based on technologies and strategies taken over from existing matured solutions developed for auxiliary dc systems in big power plants and traction power systems [77]. Recently, however, a number of new coordinated protection strategies have been proposed [78]–[84]. Apart from protection systems, standardization of future dc systems regarding dc voltage levels, installation design, maintenance practices, and instrumentation and control recommendations are at present moment the most important barriers to wide-scale adoption. Organiza-

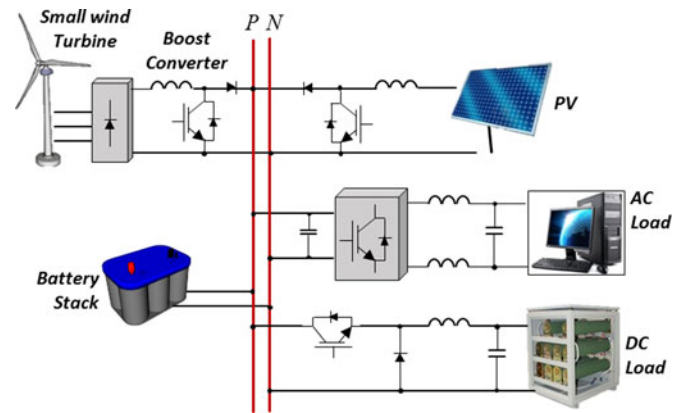

Fig. 1. Single bus dc MG with ESS directly connected to the common bus.

tions such as EMerge Alliance, IEC, and IEEE are engaged in developing voltage and performance standards.

This paper is not only motivated by the recent outburst of publications in this area, but also by an immense amount of their real-world residential and industrial deployments [69], [85]–[88]. It is intended to supplement its first part which is more focused on control issues, stability analysis, and stabilization techniques for dc MGs. The organization of this paper is as follows. In Section II, a configuration of the dc MG system is presented and various circuit topologies are shown. Section III points out four practical dc MG applications and presents critical discussion about particular performance requirements for each one of them. Applicability of different architectures described beforehand and control strategies presented in the first part of this paper are also evaluated. Section IV sheds light on the current status of protection for dc MGs. For that matter, discussion about possible types of faults is followed by a description of prominent protection devices and grounding methods, and also their integration into overall coordinated protection strategies.

Overview of available dc standards and those under development is given in Section V. Finally, Section VI presents the concluding remarks.

## II. DC MG SYSTEM OVERVIEW

Typical dc MG systems are reviewed here. There are a number of topologies that have been reported in the literature and some of their most prominent representatives are assessed in this section. In general, the topologies of dc MG can be classified into three categories, i.e., single-bus topology, multibus topology, and reconfigurable topology, respectively.

### A. Single-Bus Topology

Single-bus topology is commonly used for dc MGs, and it can be regarded as the basis of multibus systems. Fig. 1 shows an exemplary schematic diagram of the most common type of dc MG, which is frequently deployed in practical industrial applications. It is based on the singular dc bus to which ESS, typically an electrochemical battery stack, is directly connected [89]–[92]. The

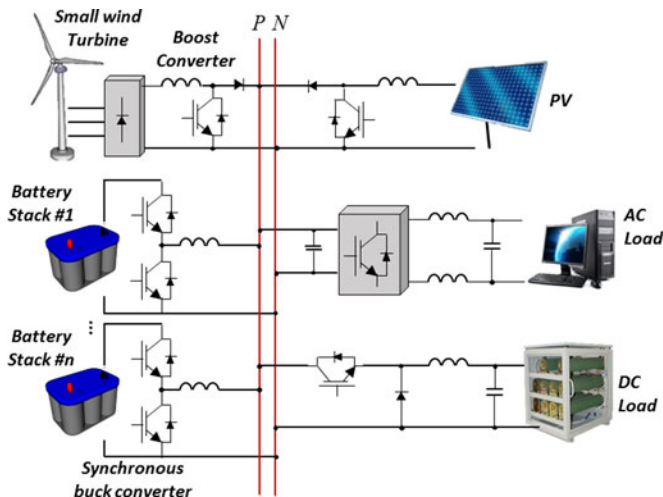

Fig. 2. Single bus dc MG with ESS connected to the common dc bus through dedicated converter.

number of series battery cells is determined depending on the voltage required by loads. Electrical power supply systems for telecom applications have been historically using this configuration operating at 48 V [93]. Many types of converters that can be seamlessly connected to the bus operating around this nominal voltage are available in the market (e.g., [94]). However, despite inherent dynamic stability of the system, an uncontrollable voltage in the common dc bus, which depends mostly on the state of charge (SoC) and current of the battery, limits its application only to dense, singular bus systems [70]. Apart from that, it suffers from the practical problem of unregulated battery charging as it needs to be performed coordinately by a number of paralleled converters that have inherent imperfections in bus voltage measurement. This causes a circulating current problem that leads to uneven loading of those converters [4], [95]–[97], and also to accelerated wear and tear of stationary batteries [70]. On the other side, connection of the ESS through dedicated converter interface to a regulated low-voltage dc bus (see Fig. 2) allows application of more flexible control and possibility of connecting multiple buses for enhancing the reliability of the system or to supply loads in a wider area.

Moreover, the reliability of this system can be increased by using multiple battery stacks. This topology, operated at low voltage, has by now been the most widely studied in the literature [15], [18], [46], [48]–[50], [55], [98]–[103]. However, its attractive features are partially counterbalanced with several associated technical problems. First, there now appears a need for careful design of circuit and control parameters due to a fact that equivalent capacitance of dc bus gets much smaller than in case of direct battery connection. Second, there exists only one dc bus, compelling the consumers to be powered from it.

As a practical remedy to the aforementioned problem, several alternative concepts have been examined. Kakigano *et al.* proposed a bipolar single regulated bus structure (see Fig. 3), that operates at  $\pm 170$  V [20]. The main benefit of this configuration is a fact that load-side dc–dc converters have an option to choose

the source voltages between 340, +170, and  $-170$  V. Therefore, the reliability of the system is increased since in case of failure of one line, it is still possible to supply power by the other two lines and an auxiliary converter.

### B. Multibus Topology

Besides the single-bus topologies, dc MGs can be extended to multibus configurations aiming at higher availability and reliability. An interesting topological modification for enhancing the reliability of the system in that sense was proposed by Balog and Krein [54]. It is based on the automated hot-swap principle between more buses using the method of auctioneering diodes. In that particular work, the case of two redundant buses is analyzed. The location of intervention is on the load side, where critical loads automatically select the bus to be supplied from based on higher voltage. The structure of this system is shown in Fig. 4. Similar strategy for selecting the most appropriate supply bus is presented in [73], but it uses a game-theoretic approach. In that case, loads are more flexible to define the way of selecting desired bus, and several objective functions are tested for that matter. Besides, simultaneous supply from multiple buses is possible in order to enhance the total efficiency of the system.

Multiple dc MG cluster configuration (see Fig. 5) is an alternative redundant solution [19], [74], [104]. In this way, every MG is able to absorb or inject power from its neighboring MGs in case of shortage or surplus of power, respectively. Additionally, depending on the configuration in which the MGs are connected, some corrupted buses can be automatically isolated from the system in case of failure. Power exchanges between multiple dc buses are regulated by imposing appropriate local voltage deviations. However, by dint of digital communication technologies, total average voltage can be regulated to a nominal value [74].

Low-voltage dc distribution systems can be interfaced to medium-voltage ac utility mains through SST, as shown in Fig. 6. With connection of a number of SSTs to medium-voltage ac network, it is envisioned that the energy management in lower voltage levels will be completely in SST domain, largely simplifying the task of system operator in the ac grid above SST [72]. However, although it is widely deemed that SSTs will bring a new revolution to future distribution systems, serving as the true enablers of dc distribution architecture, they are still in the early development stage [105]. Recognizing its potential, many academic and industrial projects around the world, such as FREEDM [106], UNIFLEX [107], and HEART [108] are currently underway, focusing on pushing this technology to the next technical readiness level. Speed of its further evolution will to a large extent determine the significance of the role of dc distribution in future power systems. It is expected that previous advances in dc MGs area will play an instrumental role in realizing the SST scenario [51].

### C. Reconfigurable Topology

Besides the aforementioned architectures of dc MG, reconfigurable topologies were also proposed for the purpose of

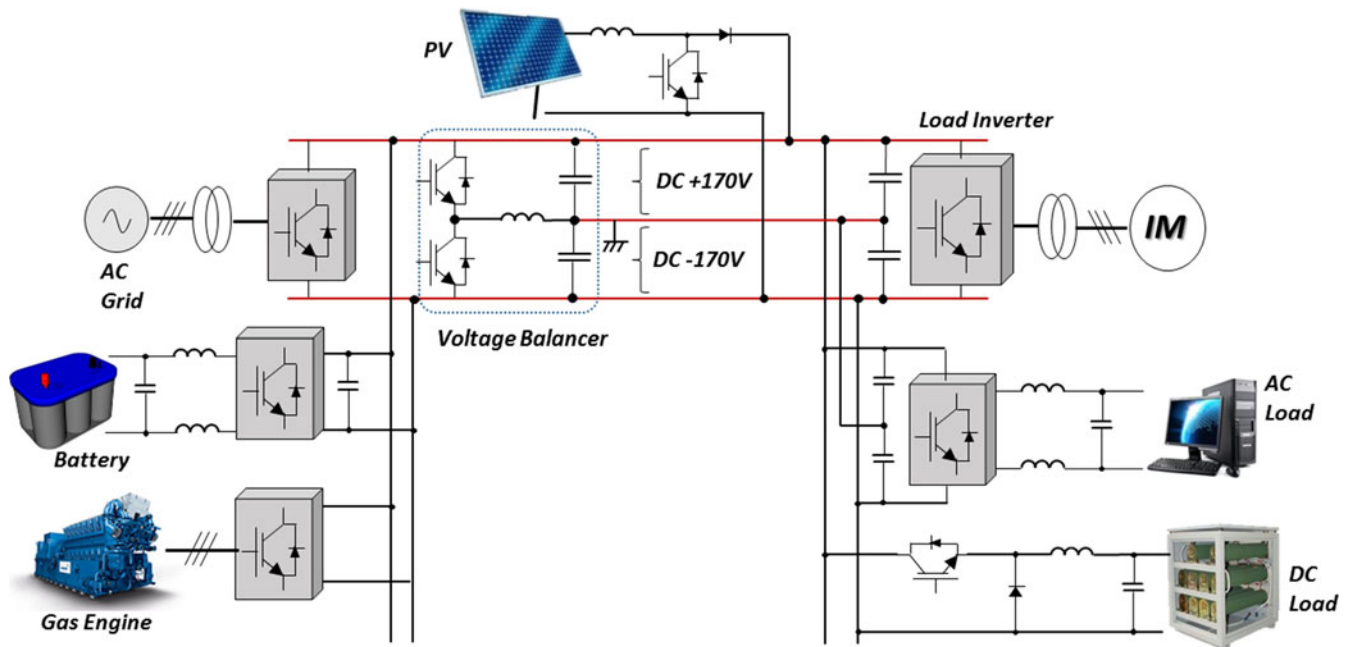

Fig. 3. Bipolar single bus dc MG.

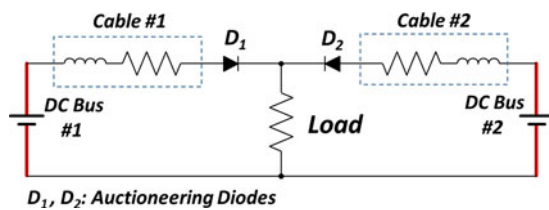

Fig. 4. Dual-bus, separately fed dc MG with a bus selector at each load.

increased flexibility during the faults or periodic equipment maintenance periods. Fig. 7 shows a dc ring bus architecture [81]. Each node and the link between neighboring nodes are controlled by intelligent electronic devices (IEDs). The main merit of this configuration is high reliability and redundant operation. Since the load connected to the common dc bus can be fed bidirectionally, alternative path is provided at the ring bus in case of fault. When encountering a fault in this dc MG, the fault is isolated by IEDs first, and then the load power turns to be supplied by the sources in the normal alternative path.

Another dc MG architecture that features high reliability is based on zonal configuration, as shown in Fig. 8 [75]. It is seen that this type of dc MG is comprised of multiple dc distribution units, with each one of them being connected in series to form a zonal architecture. Note that each dc distribution unit in the zonal configuration has two dc buses. These two buses form the redundant configuration and the required load power can be flexibly obtained by either one of them. In particular, assuming that the load power is supplied by the upper bus, in case of its failure the switches at the upper side are turned OFF and the switches at the lower side are turned ON to change the source bus and ensure the normal operation of the load. Meanwhile, since

each dc distribution unit in the zonal architecture is powered by the utility grid separately, fault can be isolated within each unit without influence on the operation of other parts of the zonal system. This topology is similar to the redundant bus system proposed in [54], but it has better flexibility due to higher number of switches.

Multiterminal dc (MTDC) system is proposed in [109]–[111], as shown in Fig. 9. It should be noted that the MTDC architecture was originally proposed for high-voltage dc (HVdc) systems, e.g., off-shore wind farms. In this configuration, the dc distribution network is fed by multiple input terminals. The system usually features mesh configuration. Compared to conventional radial configuration, power flow in mesh configuration is more complicated. However, it can be also more flexible since the system connection provides multiple paths for power transmission.

Table I sums up the hardware topologies that have been presented above and gives critical comparisons from different points of view. The voltage levels of each configuration reported so far in the literature are listed. Some of the configurations can be implemented by using standardized off-the-shelf components, such as industrial inverters. However, for the others, specialized components are required. For example, dc voltage balancers are needed for the configuration with bipolar regulated bus, while SSTs are required for SST-enabled MGs. IEDs should be used for reconfigurable dc MG architectures. Considering the impact of ESS, its type of connection to the dc MG is also summarized. In relation with this, it is shown that configurations which can incorporate directly connected ESS have inherent stability. Final two columns of the table present two performance metrics of each configuration, i.e., expandability to multiple buses and reliability.

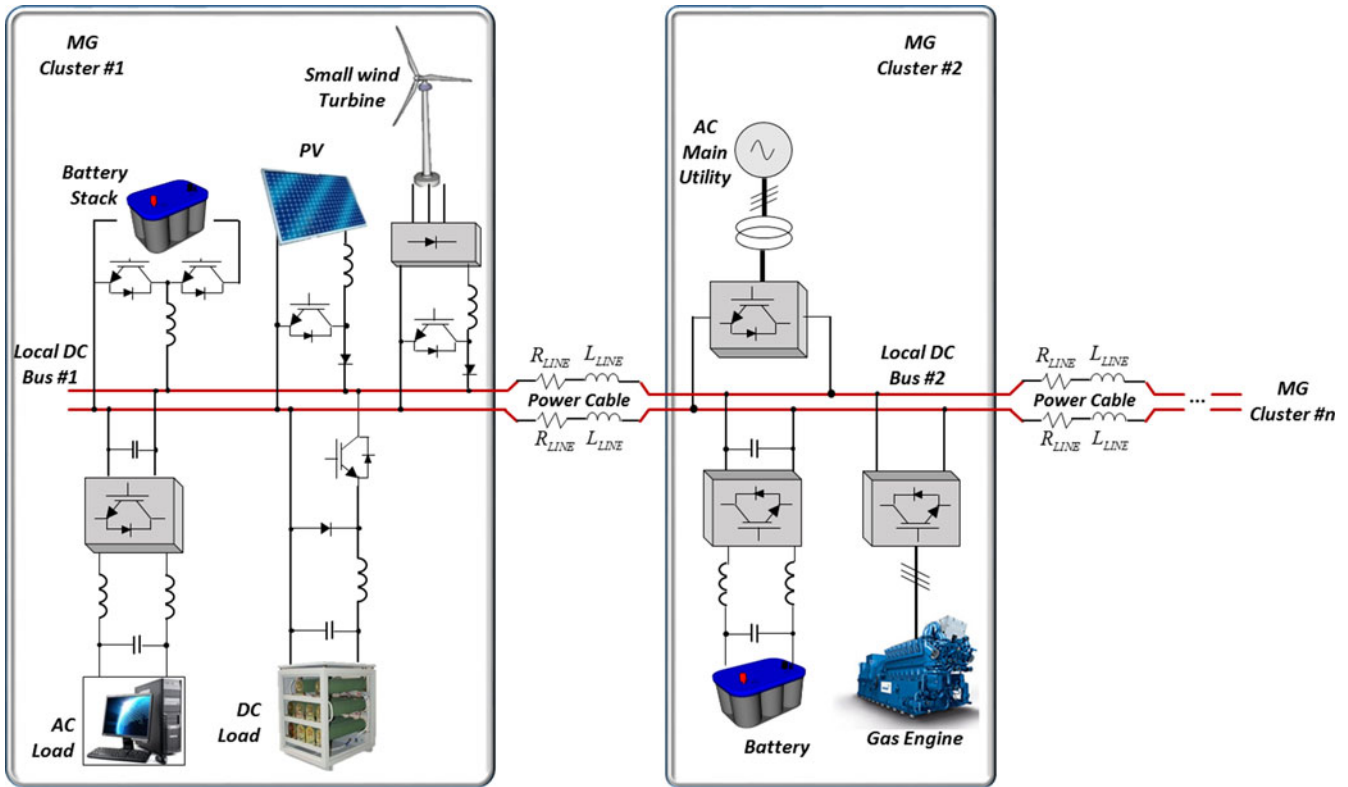

Fig. 5. Multiple bus dc MG with all components connected through dedicated converter interfaces.

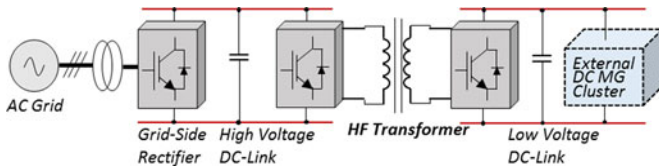

Fig. 6. SST-enabled dc MG.

#### D. Interconnection Between DC MG and AC Grids

In order to ensure the power availability and reliability, dc MGs can be interconnected with existing ac infrastructures through dc–ac converter interface. In that way, either an ac grid connection or a hybrid ac/dc MG can be established. In any case, dc link is typically used for efficient local coupling of dc-type components. The interface toward ac grid is reflected in most architectures presented in previous sections and can be achieved by unidirectional or bidirectional dc–ac converters. In case of a hybrid MG, dc MG can be regulated to absorb power from the ac MG when it has surplus of power. On the other hand, when load requirements exceed the available power, dc MG can deliver it back to the ac side (only if bidirectional interface is used).

Focusing on the power architectures of the interconnecting energy conversion systems between dc MGs and ac grids, some work has been done in the existing literature. In general, the interconnecting system can be classified into three categories, i.e., single, parallel, and aggregated converter system.

The single converter to link the dc MG and ac grid is usually used in small-scale systems. In [112], a PV-wind-battery hybrid MG is taken as an example to represent the ac and dc hybrid MG. The PV panel and battery form the dc bus, and the wind turbine and ac utility grid form the ac bus. Since the power capacity of the above system is typically not so large, a single bidirectional converter is used to link the dc subgrid and ac subgrid. In [113], an integrated configuration is employed with one ac–dc–ac converter as the energy hub to connect both ac and dc subgrids. In particular, the ac MG and ac utility grid are connected to the two ac sides of the ac–dc–ac converter, respectively. Meanwhile, the dc link of the converter is connected to the dc MG. Systematic power flow management among the ac utility grid, ac MG, and dc MG is designed to achieve the coordinated control.

In order to increase the exchanging power capability between dc MGs and ac grids, parallel interface converters can be used between the ac and dc bus. In [114], parallel converters between ac and dc bus are analyzed in detail. The model of the parallel converters is derived and the control system is designed to suppress the zero-sequence circulation current. In [115], parallel bidirectional interlinking inverters are used to connect the dc subgrids and ac subgrids. An improved droop control method based on per-unit frequency and amplitude is employed to enhance the power sharing among different converters. Meanwhile, it is pointed out that the proposed method also applies for different architectures with both ac and dc subgrids. In [116], different operation modes are studied and the one with ac to dc power flow is discussed in detail. A hierarchical control system

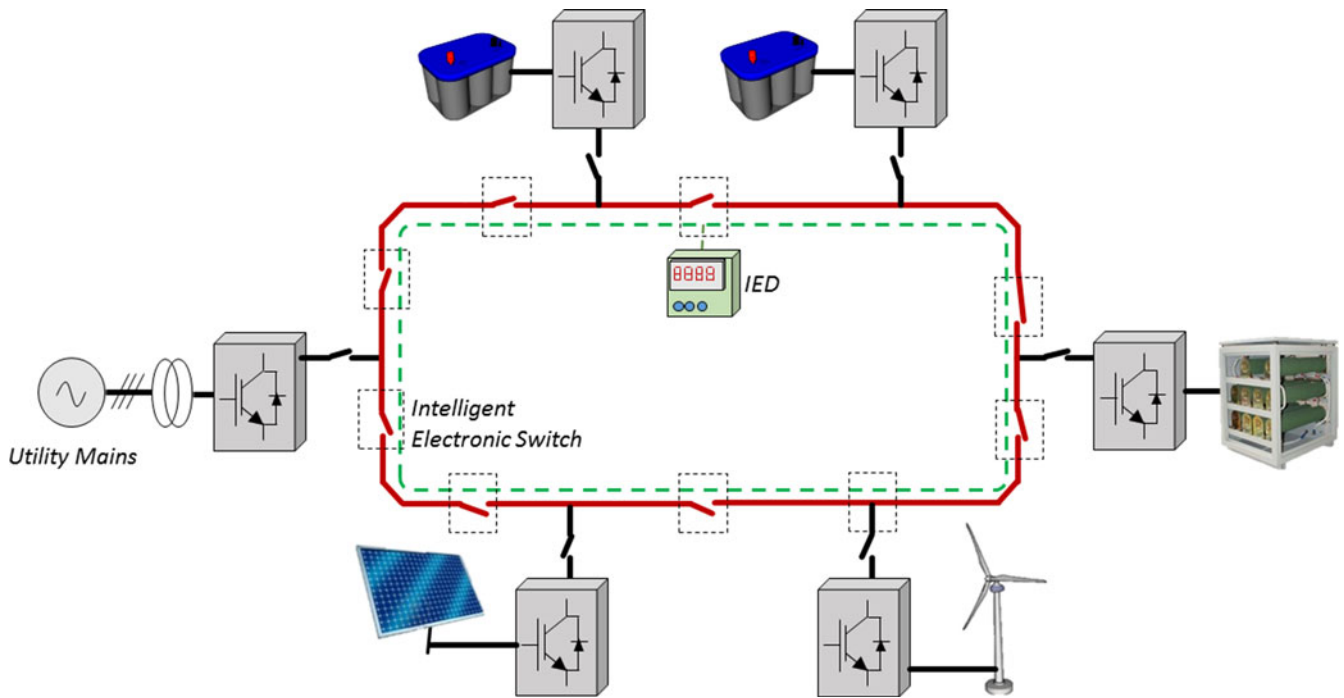

Fig. 7. DC MG based on ring bus.

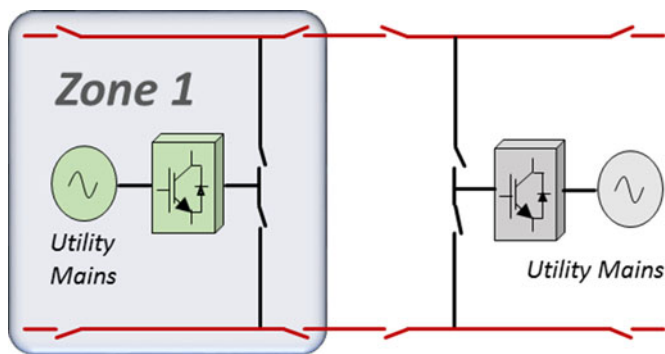

Fig. 8. Zonal dc MG.

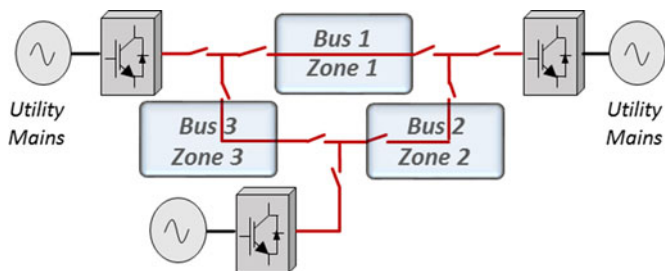

Fig. 9. MTDC MG.

is used to ensure the reliable operation of the whole ac and dc hybrid MG.

Apart from the configurations with single and parallel interface converters, the aggregated configuration is also employed

for ac and dc hybrid MGs. In [117], a hierarchical architecture is proposed to aggregate the dc MG with ac MG and ac utility grid. In Level 1, which is a microsource level, dc MGs are formed to integrate the DGs and energy storage units. In Level 2, combo-source level, each dc MG is connected to an ac link by using dc–ac bidirectional inverters. In Level 3, MG level, several ac-coupled combo sources are aggregated to form a MG and to achieve the functions of optimization, synchronization, dispatching, protection, etc. Finally, each MG in Level 3 is connected to the ac utility grid, respectively. In [118], the sources and loads in an ac and dc hybrid MGs are categorized into three groups, i.e., DG park, dc MG, isolated ac MG, and ac utility interface. An admittance-based model is derived and the overall system is thereby studied from the dynamic stability point of view. Considering the power architectures reviewed in Sections II-A–II-C, their capability of interconnecting with ac utility grid or ac MG depends primarily on the availability of high enough dc-link voltage level. For that matter, only in the single-bus dc MG with directly connected battery, there is no possibility of direct dc-link voltage control. However, it may still be connected to utility mains if an adequate number of battery cells are connected in series.

As a final remark, it should be noted that although the power architectures were presented in this section within the MG framework, they have a quite general structure. In that sense, the vast majority of them can be used in a very broad voltage and power range, given the proper selection of semiconductor devices and/or their arrangement within the multilevel converter structures. For that matter, a resemblance with typical architectures used in HVdc systems can be readily observed (see, i.e., [119]). In the respective reference, singular bus, bipolar bus,

TABLE I  
OVERVIEW OF HARDWARE TOPOLOGIES FOR DC MGs

DC Bus Configuration	Reported Voltage Levels (V)	Standardized Components	Direct ESS Connection	Inherent Stability	Expandability to Multiple Buses	Reliability
Direct battery connection	12, 24, 48	Yes	Yes	Yes	No	High
Single unipolar regulated bus	24, 48, 380	Yes	No	No	Yes	Medium
Bipolar regulated bus	$\pm 170$ , 340	No	No	No	Yes	Medium
Multiple regulated buses structure	48, 380	Yes	No	No	Yes	Medium
SST-enabled MG	380 and higher	No	Possible	If ESS directly connected	Yes	Medium
DC ring bus	Lab tests made at 24 V but suitable for higher	No	No	No	Yes	High
Zonal DC MG	380 or higher	Yes	Possible	If ESS directly connected	Possible	High
MTDC MG	380 or higher, and commonly used for HVdc systems	Yes	No	No	Yes	High

multiple bus, multiterminal, and ring bus structures have been shown to be used in HVdc systems up to levels of 350 kV. The exception is the topology presented in Fig. 1, which has a direct connection of the battery stack that is not typical for HVdc systems. Therefore, that topology is voltage limited by the battery, and the required voltage in that case is achieved by stacking up the number of low-voltage battery cells in series. However, it is not viable to increase the number of cells indefinitely due to problems associated with balancing of individual cells and reliability (if one cell fails, the whole stack will fail). To the best knowledge of the authors, the highest reported voltage of a battery stack by now is 6 kV [120].

The thorough discussion about the applications of each topology specifically for four emerging dc MG applications is provided in the following section. It presents the typical performance requirements and applicability of corresponding power architectures, together with the summary of suitable control strategies in that they can achieve the imposed objectives. Moreover, the typical voltage and power limitation limits for each application are given.

### III. APPLICATIONS OF DC MGs TO FUTURE SGs

Taking into account the advantages of dc MGs, their usage has been proposed for a number of different applications in future SG, with each one of them having its own specific requirements. In this section, a critical view on performance requirements of four modern dc MG applications is presented. They include high-efficiency households, renewable energy parks, hybrid ESSs, and EV fast charging stations, as shown in Fig. 10. While it should be acknowledged that the considered list is by no means complete, we have limited our discussion only to these novel applications of dc MGs. More details about some well-known and matured examples, such as DPSs [1]–[10], telecommunication [11]–[13], data centers [14], [15], vehicular electric power systems [16], [17], can be found in the existing literature.

Considering the specific characteristics of various power architectures that were reviewed in Section II of this paper together with control strategies that were reviewed in the first part of these two articles, a critical judgment in selecting the most suitable ones for every given application is provided below. Moreover, typical voltage and power limitations, as reported in the literature, are presented.

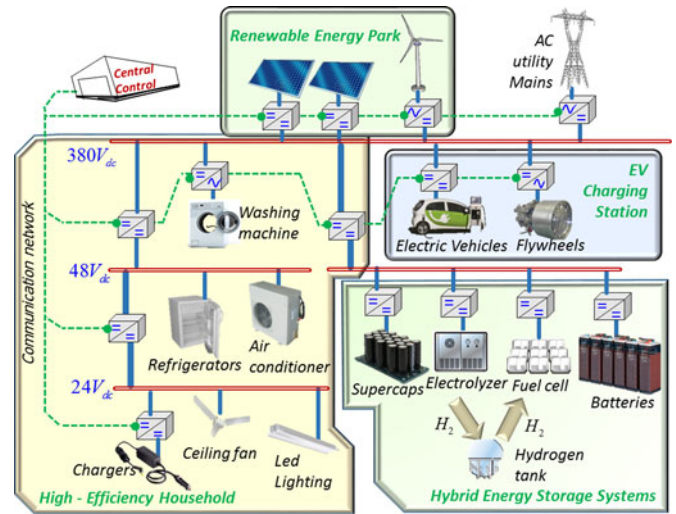

Fig. 10. Applications of dc MGs.

#### A. Performance Requirements for DC MG Applications

Desirable performance characteristics and functionalities of MGs in general were presented in [75], [121], and [122]. For completeness of this paper, they are summarized here by considering both the control and architectural perspectives. From control point of view, MG should be operated in a stable way and provide sufficient power quality at the point of common coupling (PCC). Moreover, it should provide functionalities, such as intelligent coordination of its internal units, as well as grid support capability when it is in grid-connected mode. These can be summarized as follows:

- 1) stability: sufficient stability margins during normal and transient operating modes;
- 2) power quality: satisfactorily voltage waveform in the common dc bus;
- 3) coordinated control: supervisory energy management system responsible for carrying out complex functions, such as economic dispatch, unit commitment, mode changing, efficiency optimization, and power flow control between internal clusters;
- 4) grid support capability: ability to provide ancillary services to the overhead ac power system.

TABLE II  
TYPICAL PERFORMANCE REQUIREMENTS FOR VARIOUS DC MG APPLICATIONS

DC MG Application		Hardware Architecture			Control Strategy	
		Redundant Power Supply	Flexibility	Scalability	Coordinated Control	Grid Support Capability
High-Efficiency Households	Importance Level	Low	Medium	High	High	Medium
	Description	Leads to higher installation cost.	Flexible clustering of households is a promising future concept.	Should continue working with new appliances integrated into household.	Efficiency and economic optimization in both single household and cluster should be achieved.	Households are conceived to support the grid indirectly—according to the price signal.
Renewable Energy Parks	Importance Level	Medium	Critical	Medium	High	Critical
	Description	Individual faulty unit can be bypassed so redundant power supply is not highly required.	Flexibility in terms of bypassing faulty elements should be guaranteed for fault ride through and occasional maintenance of RES generators.	Number of units within a branch can be defined considering the required voltage level but more branches can be added if the power rating of central inverter permits.	Required when there is a need to coordinately increase or reduce power production of multiple generators.	Required by grid codes for renewable energy systems.
Hybrid ESS	Importance Level	Medium	Low	High	High	High
	Description	Would not give too much benefit due to a fact that all units are typically connected to the same point.	Small and dense systems formed around a common dc bus. Probability of fault on dc bus is extremely low.	Plug and play of additional sources for expanding energy and/or power capacity is highly desirable.	Degradation of ESS and grid price signal can be integrated into cost function.	Important for grid support in some cases such as renewable energy parks or EV charging stations.
EV Fast Charging Stations	Importance Level	Medium	Medium	Medium	High	High
	Description	Too costly and not competitive with present commercial solutions.	In case of chargers aggregated in parking lots, reconfiguration and fault ride could increase reliability.	Plug and play capability of additional ESS will be a desirable feature when grid codes start to be imposed.	Optimization of charging strategies, charging scheduling, energy management between grid and ESS.	Grid codes are still not adopted, but will become important issue when they do.

On the other hand, from architecture point of view, functionalities that can be achieved through appropriate power architecture include redundancy, flexibility, and scalability. They can be summarized below:

- 1) redundancy: redundant power supply for the loads with minimized reliance on communication;
- 2) flexibility: possibility of reconfiguring the system online during faults and/or to form MG clusters;
- 3) scalability: possibility to seamlessly add or remove units within MG.

Among the items given above, stability and power quality in control strategy category can be interpreted as characteristics of the system. Although they have been treated in unitary fashion in [75], [121], and [122], here we draw the line between them and the other functionalities. The reason behind this is a fact that stability and sufficient power quality are mandatory objectives for every dc MG without exception. Also, the interventions to enhance stability margins and power quality mainly rely on local control diagram with the assistance of system level coordinated control to limited extent. The function of stability enhancement is programmed at the converter architecture and/or lowest control level. In particular, it can be improved by incorporating passive and active damping techniques, which are implemented

either by inserting passive elements within the converter filter or adding control loops within the local control, respectively, [123], [124]. On the other hand, power quality is related to the waveform of the voltage in common dc bus, and influence over it can also be achieved by proper combination of low-level architecture and control. One example of such a manipulation is interleaving number of dc–dc converters to reduce the voltage ripple and improve the transient response [125].

Here, we attempt to assess the extent to which the remaining five benchmark functionalities, i.e., redundancy, flexibility, scalability, coordinated control, and grid support, are relevant for viable performance of every addressed application. For that matter, we designate each one of them with one of the four levels of importance, i.e., low, medium, high, and critical.

Detailed elaboration about particular applications and importance of specific functions for their proper operation are given in following sections. The resulting evaluation is summarized in Table II. Moreover, through each of the sections, practical hints on how to meet specific objectives by choosing adequate combination of hardware architecture and control strategy are presented. Summary of that particular assessment is presented in Table III. In addition, Table III shows the typical voltage and power limitations reported for each particular application.

TABLE III  
SUITABLE CONTROL STRATEGIES AND ARCHITECTURE

Application	Control strategies	Architectures	Typical voltage limitation	Typical power limitation
Future households	Appliance scheduling—centralized, decentralized or distributed Adaptive droop control—for the cases when ESS are installed within the households	Single bus dc MG Bipolar single bus dc MG Redundant bus system—for mission critical applications Multiple dc MG clusters	For safety reasons, the maximum voltage for this application is commonly selected as 400 V.	Up to several tens of kilowatt for individual households.
Renewable energy parks	MPPT Grid support functionalities Coordinated control (when reduction of available production is required)—typically centralized	Single bus dc MG—for smaller scale parks Ring bus dc MG etc., with enhanced fault-tolerant capability Multiple dc MG clusters with fault isolation capability—virtually equivalent to series-parallel collector grids SST-enabled dc MG—for larger parks with connection to MV ac networks	Medium-voltage dc buses have been deployed to avoid multiple step-up transformers. A solution utilizing 7.5 kV has been reported in [155]. Highest analyzed voltages for offshore wind parks achieved by using series dc configuration were up to 300 kV [156].	Largest dc onshore and offshore renewable grids are in range of several hundred megawatts [156], [157].
Hybrid ESS	SoC estimation Charging algorithms Adaptive droop control—equalizing SoC of multiple ESS of same type DC bus signaling—coordination between ESS of different types	Single bus dc MG with direct connection of battery Single bus electronically regulated bus dc MG	The vast majority of hybrid ESSs reported in the literature is designed for 24, 48, and 380 V dc buses. However, higher common dc bus voltages such as 750 V have been used in some applications [158]. For a sole battery storage, 6-kV prototype has been developed [120].	Total power capacity depends on application but will in general never exceed the nominal power of a given application. Commonly, it is sized at approximately half of the nominal power (e.g., for smoothing power fluctuation of 2-MW wind turbine, optimum of 1-MW hybrid ESS is computed [159] while in a generic dc MG of 10 kW, 6 kW is used [160]).
EV charging stations	DC bus signaling—current sharing between grid-tied converter and ESS converter Adaptive droop control—sharing between multiple ESS SoC estimation Consensus algorithms—alternative for coordination between grid tied and ESS converter Charging algorithms—on site chargers typically have preinstalled a number of algorithms for different HEV batteries Grid support functionalities	Single electronically regulated dc bus for single charging station Multiple dc MG clusters or ring bus dc MG in case of multiple parking lots SST-enabled dc MG for larger stations with MV ac connection Ring bus dc MG etc., with enhanced fault-tolerant capability	5-kV MV dc substation for powering EVs was reported in [161]. However, much more common solution is to use step down transformer and establish lower voltage dc bus through rectifier interface [24], [162].	Maximum individual dc type chargers are rated at 240 kW [163]. However, more of these may be connected in parallel around the common dc bus.

### B. High-Efficiency Households

Since the majority of modern household energy sources and loads, e.g., PV panels, batteries, LEDs, and consumer electronics operate naturally at dc, it is more efficient to connect them around the dc bus to form a dc MG [126]. There are several demo projects of dc high-efficiency houses all over the world shown in the existing publications and project websites, such as USA [21], [22], Japan [20], Korea [127], and Denmark [128]. In contrast to the traditional ac system, dc system has higher efficiency. The energy saving opportunities by changing infrastructure from ac to dc can be up to 15% [129].

Except of benefits from the efficiency point of view, the control simplicity in case of dc makes it a much better option for integration of energy management systems. For this reason, dc MGs are excellent candidates for households that could greatly facilitate the achievement of objectives imposed by a number of present SG roadmaps, which state that increase in flexibility<sup>1</sup> of household consumers is a key for sustainable operation of the

future grids with high penetration of renewables [130], [131]. For that matter, real-time price signal is predicted to be the main driving factor that will motivate local households to rethink their distribution of energy.

In order to achieve flexibility, it is important to establish coordinated control of appliances within the households. It should be noted that integration of local ESSs with controllable appliances can also greatly aid to this functionality. Finally, all these units can be grouped into a number of clusters, where each one of them could absorb from or inject energy to other neighboring cluster(s), depending on the conditions of the system. In this way, even higher degree of flexibility and, consequently, larger potential to obtain concrete economic benefit can be obtained. While clustering of households is still at notional level, there are several published works that help in understanding the benefits of this concept [19], [74], [132].

The most common objectives in control of future households are reduction of the energy cost and maximization of customer comfort [132]–[137]. These objectives are most commonly achieved by scheduling the appliances within the households through various unit commitment strategies. In that sense, the respective appliances are typically coordinated on a higher

<sup>1</sup>Flexibility of consumers mentioned here is related to controllable power extraction from the grid and is different from the hardware flexibility addressed in Section III-A.

level in ON/OFF fashion and are not responsible for the voltage in the common dc bus. Therefore, the local control strategies do not apply since the voltage is regulated to a constant value by a grid-tied converter. Coordination based on the scheduling of appliances using decentralized [132], distributed [133], and centralized [134]–[137] control methods have been proposed.

Higher level of flexibility can be achieved if complimentary ESSs are used within the households. In that case, some of the control techniques presented in the first part of this paper can be deployed. For instance, in [138], the control method for a PV-based building with coordinated operation of batteries has been proposed to avoid the permanent active power injection to the utility grid. In [20] and [139], the bipolar configuration of dc MG has been proposed, which is useful to further enhance the dc power quality. Meanwhile, fuzzy droop control has been employed to reach the dynamic balancing of the SoC of each energy storage unit. In [140], batteries and heat pumps have been used as controllable loads in order to eliminate the power fluctuation by PV plant at the PCC. An optimized search algorithm was deployed to minimize the difference between highest and lowest power flow from the utility mains.

Regarding suitable hardware architectures, the single bus system shown in Fig. 2 is the most suitable configuration. In special cases, where redundant power supply is needed, configurations from Figs. 3 or 4 can be used. Finally, structure from Fig. 5 is appropriate for the application of multiple household cluster concepts.

### C. Renewable Energy Parks

A number of RESs can be clustered around the common dc bus to form an energy park. In that way, the system efficiency can be increased and issues such as reactive power circulation and harmonics avoided [126]. These kinds of dc systems are sometimes also referred to as the collector grids and are used for both photovoltaic and wind power applications [141], [142]. Compared to households, they present a different perspective, since they inject large amounts of power into the conventional ac power system and have more direct implications on its operation. Therefore, they need to be able to provide a number of ancillary services defined by well-established grid codes [143], [144]. As compliance with grid codes often implies reduction of active power injection to the grid, coordination between multiple renewable generators, which should achieve this task simultaneously, is mandatory. Several applications of dc collector grids are presented in the following paragraph.

A highly integrated dc module is developed in [39]. It provides the functionality to connect parallel interfaces for RES which share the same dc bus and have the same dc output value. In [40], a dynamic adaptor is proposed in a PV-based dc MG. The adaptor is connected at the output side of the solar field to cope with the randomness in the electrical production. Meanwhile, it can provide auxiliary function when the local dc MG is connected to the utility ac grid. In [41], in order to maximize the power utilization, the design and implementation of the multiple MPPTs is presented. The coordinated operation among different trackers is studied. In [42], a switched boost converter is

developed. This kind of converter can supply both ac and dc components, simultaneously, which makes it possible to behave as the interface to the local dc loads and external ac grid. In [43], a solar converter with high voltage gain is proposed to harvest maximum power from solar panels. From the system level point of view, the energy management system for renewable energy parks has also been studied. The cost and stability of a dc-coupled renewable energy park with hybrid sources is analyzed in [145], where the forecasting model for different sources and loads is also developed. In [146], the optimal allocation and economic analysis for the energy storage units for renewable energy parks is studied. In [147], the detailed power loss model is derived to optimize the system efficiency.

Regarding typical hardware configuration of large collector grids, a number of wind turbines or PV generators are connected in series to form a branch, which operates at a nominal dc voltage. Then, number of branches are connected in parallel to form a complete collector grid [148]. A critical function here is a fault ride through since stop of production presents a big economic loss. In particular, when one unit in a branch fails, it is necessary to bypass it in order to maintain the healthy units operational. On the other hand, branches are typically designed for a specific voltage, and if the power rating of the central inverter permits, additional branches can be added to expand the power rating of the whole system. In relation to architectures presented in Section II, single bus system of Fig. 2 can be used for smaller scale applications. On the other hand, for larger parks, connection to MV ac network can be achieved through SST, as shown in Fig. 6. Finally, as series–parallel collector grids resemble the structure of multiple clusters of Fig. 5, this configuration can be used to achieve desired dc-link voltage by connecting number of generators in series. It should be noted that for the sake of maintenance and fault ride through capability, it is mandatory to incorporate possibility of bypassing any given generator. In order to enhance the fault-tolerant capability, dc ring bus configuration in Fig. 7 and other configurations with higher reliability can be considered.

### D. Hybrid ESSs

ESS technologies are characterized by several important performance indicators, such as energy efficiency, energy and power density, cycle life, and rate of self-discharge [149]. In that sense, for situations when a single ESS is not able to meet the prescribed requirements of specific application, it is advisable to combine two or more technologies that complement each other. Since dc distribution offers a natural interface for practically all types of ESS, these kinds of hybrid ESS are frequently deployed around the common dc bus.

A large number of hybrid ESS applications have been reported in the literature and only several selected ones are shown here. From architectural point of view, the majority of applications are small and dense systems gathered around the common dc bus, which can be established either through direct connection of the battery stack or through regulated power electronic converters. Since the bus is small, the most common faults in these kinds of systems are directly on storage units and design

of fault ride through capability based on bypassing the faulted part of the common dc bus would unnecessarily complicate the system. On the other hand, plug and play capability is a highly desirable feature which can be exploited either for extending the power or energy capacity of the system [55]. Optimization of charge/discharge processes among different technologies is another important aspect. Objective function in this regard usually incorporates terms related to degradation of respective ESS technologies according to imposed mission profiles and can be executed online [150] or offline for capacity optimization [151]. In grid-connected applications, variable grid price signal can be incorporated as well within the objective function. In the remainder of this section, several hybrid ESS applications are reviewed.

The most common representative of hybrid ESS is secondary battery in combination with supercaps. In [33], a model predictive control has been employed to enforce super-caps to absorb only fast power changes, prolonging the lifetime of the battery in that way. Superconductive magnetic energy storage (SMES) was combined with battery in [34]. In this case, fuzzy control was used to make SMES act as a power buffer, while the battery is responsible for slower variations. A single synchronous buck converter was used as an interface between fuel cell and battery in [35]. Associated control was designed with the objective to share the pulsed current with respect to permitted voltage ranges of the two ESS technologies. Similar, but more reasonable approach which uses supercaps instead of batteries, and bidirectional isolated dc–dc converter, was presented in [36]. With the aim to operate compressed air energy storage at its highest efficiency during every operating condition, its supplementation with super-caps was investigated in [152]. Finally, as larger architectures in case of hybrid ESSs would bring unnecessary losses and complexity, the two most common power architectures are those shown in Figs. 1 and 2.

### E. EV Fast Charging Stations

EVs have gained increasing attention due to potential of reducing the greenhouse gas emissions and conventional fuel consumption. However, it has been shown that their large-scale integration could have a significant adverse effect on the electric grid [26] and dc MGs have been conceived as a promising solution to support the operation of the power system by aggregating multiple EVs [153]. Fleets of PHEV chargers represent a specific group of consumers with an outstanding potential from the increase of flexibility standpoint.

It is deemed that grid codes similar to those imposed for RES will be developed for fast dc charging stations, especially when the level of their penetration becomes more significant. In contrast to vehicle to grid where energy stored in vehicle's battery is used for grid support, charging stations with supplemental ESS have been proposed not to disrupt the recommended charging pattern of the vehicle's battery. In that sense, different types of energy storages can be employed in the dc EV charging stations, such as flywheel, battery, and hybrid ESSs [153]. Internal coordination between the ESS and grid is an important but challenging task, since number of objectives need to be simultaneously met, i.e., tracking of the variable grid price

signal, consideration about degradation of particular ESS technology, and grid friendly operation. Additionally, this type of multiobjective control can be achieved in myriad of ways. In the following paragraph, several approaches used in fast dc charging applications are provided.

In [27], the traditional power quality problems caused by the integration of multiple EVs have been analyzed. In [29], the power flow related to the dc charging station is optimized online to reduce the power line losses. In [154], the economic impact to the cost and benefits for installing the EV charging station is studied. Distributed bus signaling strategy was used in [23] to coordinate operation of grid and ESS converters. Flywheel based on induction machine was used in this particular application since it does not introduce significant performance degradation problems with cycling as batteries.

In order to reach an efficient power conversion in EV charging stations, different topologies of power electronic converters can be used. In [28], the topologies of nonisolated bidirectional dc–dc converters are reviewed to derive the suitable solution for the EV charging station with multiple parking decks. In [105], SST-based fast EV chargers are developed to reduce the size of the interfacing converters. It can be noted that configurations like single bus dc MG in Fig. 2, multiple dc MG clusters in Fig. 5, SST-enabled dc MG in Fig. 6, and fault-tolerant configuration such as ring bus dc MG in Fig. 7 can be used in case of parking lots.

Based on the above discussion for each specific application of dc MG, the suitable control strategies and architectures for each of them are summarized in Table III, and the typical voltage and power limitations for each application are also shown in this table.

## IV. GROUNDING AND PROTECTION ISSUES IN DC MGs

As opposed to many advantages that dc systems bring in relation to ac, design of their protection represents a considerable challenge. The most important aggravating circumstance in that view is problem with extinguishment of dc arc which inevitably appears upon the tripping of protective devices. On the other hand, as worldwide industry has just recently started to conceive dc MGs as serious actors in future SGs, there is still a general lack of understanding and experience with operational issues of these systems [75]. Therefore, widely accepted protection standards and guidelines are yet to be defined.

The aim of this section is to update the current status in dc MG protection area. For that matter, we address four main aspects: 1) types of faults; 2) grounding options; 3) protective devices; and 4) design of protection systems.

### A. Types of Faults

Fig. 11 shows two basic types of faults that can exist in dc power systems, i.e., line to ground and line to line faults [82]. It should be noted that although less serious, line to ground faults are the ones most frequently appearing in industrial distribution systems [164]. Line to ground fault can have either low or high fault impedance, while line to line fault typically has a low impedance [45]. Moreover, a fault can occur at various points in the system, and each one of them will have different

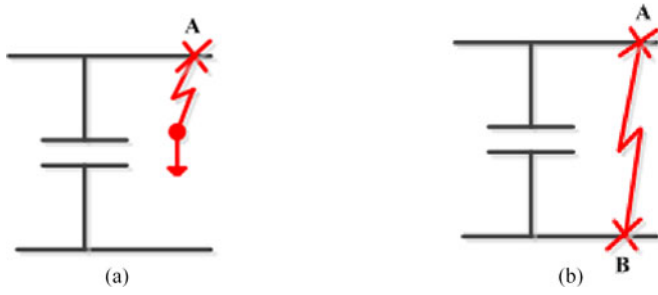

Fig. 11. Two fault types in dc systems. (a) Line to ground fault. (b) Line to line fault.

implications. For instance, unlike feeder faults that can be rapidly isolated from the main bus, faults at the main bus itself present a greater danger since all the feeders connected to it get affected [45].

When designing the protection system, it is important to identify all possible fault locations and to calculate the fault current for every given location [165]. All active sources within the system participate in the formation of the total fault current and their actual contributions depend on the effective impedances between the respective source and the fault locations. For instance, in case of bus fault, the contribution of a battery which is directly connected to the common dc bus via cable can be expressed as follows:

$$i_{\text{bat}}(t) = \frac{u_{\text{bat}}}{R_{\text{bat}} + R_{\text{cable}}} \left(1 - e^{-t/\tau_{\text{eff}}}\right) \quad (1)$$

where  $u_{\text{bat}}$  is the battery open-circuit voltage at the time of the fault,  $R_{\text{bat}}$  and  $R_{\text{cable}}$  are battery and connecting cable internal resistances, respectively, while  $\tau_{\text{eff}} = (L_{\text{bat}} + L_{\text{cable}})/(R_{\text{bat}} + R_{\text{cable}})$  is the time constant of the effective battery/cable system. On the other hand, if a battery (or any other type of source) is connected to the bus through power electronics converter interface, current resulting from quick discharge of its filter capacitor plays a pivotal role in the fault current

$$i_c(t) = \frac{u_{\text{dc}}}{R_c} e^{-t/\tau_c} \quad (2)$$

where  $u_{\text{dc}}$  is the common dc bus voltage at the time of the fault,  $R_c$  is the capacitor series resistance and  $\tau_c = C_{\text{dc}} R_c$  is the time constant of the effective converter/common dc bus  $RC$  system. If there exists a cable of considerable length between a converter and common dc bus, corresponding parameters of the cable should be included in calculation as well, resulting in a higher order dynamic system [164]. Similarly, faults that appear on feeders can be treated just as special cases of bus faults and their current contribution can be obtained by looking into effective impedances [45], [164], [166].

Total fault current can be calculated as a summation of current contributions from the battery, which is directly connected to the common bus and all other source converter currents [82]

$$i_{\text{fault}}(t) = i_{\text{bat}}(t) + \sum_{j=1}^N i_{c,j}(t) \quad (3)$$

with  $N$  being the number of source converters connected to the common bus. It should be noted that  $i_{\text{bat}}(t)$  in equation above is

optional and exist only in systems which include direct interface of the battery to the common dc bus (e.g., system shown in Fig. 1). On the other hand, the impact of line to ground faults on system performance depends heavily on the grounding method. More details about the grounding methods are given in the next section.

## B. Grounding

The most important objectives of the system grounding are to facilitate fault detection, minimize stray currents (leakage current from conductor to the ground), and to ensure the personnel safety by minimizing the common-mode voltage (potential difference between device conductor and ground) [167].

Corrosion is the main problem associated with stray current. The phenomenon of stray-current-induced corrosion was first observed at the end of 19th century, in dc-powered electrified rail transit systems [168]. The problem has been initially attributed to the chemical structure of the soil surrounding the rails, but it was soon realized that the soil cannot be the sole contributor to it since corrosion has been observed in all metallic structures around the rail base. Therefore, it has been concluded that the leakage or stray current is the main culprit for significant amplification of this undesirable effect. Stray currents cause corrosion at the locations of current leakage from conductor into the soil. Since the current flow in conductor is primarily electronic, and ionic in the soil (i.e., ground), an electron to ion transfer is inevitable as current changes its transmitting medium. In particular, this electron producing or oxidation reaction can be represented by the following [169]:

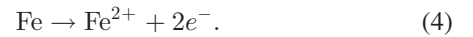

The reaction shown above is known as corrosion if it takes place over a prolonged period of time. In a broad sense, corrosion of metallic objects will occur always at places where current transfers from them to the surrounding environment. By undertaking the measures to reduce the stray current, the corrosion rate will be reduced as well and severe structural damages to conductors avoided. Apart for traction applications, modeling, assessment, and stray-current control methods have been recently also proposed for large photovoltaic plants [170], [171].

Another important metric of grounding system performance is the level of common-mode voltage. It is referred to a phenomenon where the negative pole of the bus fluctuates as the neutral of the ac side that supplies dc bus through converter interfaces [172]. In traction applications, this voltage is commonly referred to as the touch potential [167]. Although the potential difference between the positive and negative pole will be controlled to a constant value, this kind of fluctuating phenomenon presents a challenge for the operation of the system. In particular, it gets mapped to the neutral points of all the loads and generators, contributing to the loop currents between the inter-connected converters. More importantly, common-mode voltage presents a personnel safety concern if it gets exceeds the value of 60 V, which is generally considered as a safety threshold [167].

It is important to note that the common-mode voltage and the level of stray current are related to each other by the grounding

resistance. More precisely, for a very high grounding resistance, there will essentially be no stray current, but the common-mode voltage will take its maximum value. On the contrary, if the system is solidly grounded, there will be virtually no common-mode voltage, but stray current will be the highest. Therefore, the objectives to minimize both of them at the same time are conflicting with each other. However, with a proper grounding strategy, this tradeoff can be explicitly taken into account.

Different grounding alternatives have been proposed for dc power systems. Some references suggest ungrounded operation, especially for low-voltage applications [75], [173], [174]. The reason for that is a fact that the common-mode voltage will typically not be on such a high level to present a danger for personnel safety, and will offer a possibility of continuing operation even in case of a single phase-to-ground fault. Still, it is instrumental then to discover and correct a possible second ground fault or it will create a line-to-line fault [175].

In grounded mode, either a solid, low- or high-resistance grounding can be applied [45]. Solid grounding is rarely used in modern systems because of the pronounced stray-current-induced corrosion [167]. There are a number of options regarding selection of the point in the system to be grounded; it can be either a positive pole, midpoint, or negative pole of the common dc link [164]. For that matter, Jacobson and Walker [176] suggest to use midpoint grounding in order to minimize the ground potential and enhance safety. Also, the circulating current can be greatly reduced in this way in relation to ac-side neutral grounded system. IEC 60364 standard [177] defines three grounding strategies which give specifications on how the source bus and conductive parts of the system are connected to earth. The respective methods are denoted by double letter abbreviations, i.e., TN, IT, and TT. Here, first letter reveals the type of connection of source bus to the ground, whereas the second one gives the conductive part type of ground connection. T, N, and I indicate direct connection to earth, direct connection to neutral, and isolation, respectively.

In the case of TN, power line and exposed conducting parts are commonly earthed through respective midpoints, while in IT, the power line is not earthed while conducting parts are commonly earthed either on positive or negative pole. On the other hand, there are multiple grounding points in TT systems. In general, it can be said that TN systems require low-grounding impedance and that it is easy to detect a line fault when this grounding strategy is applied. However, the touch voltage may get unacceptably high depending on the voltage level at the time when fault occurs. IT systems do not need low-grounding impedance, and have very low fault current if there is a single fault. However, another ground fault is likely to induce much higher current [82]. Moreover, it is complex to detect the line fault. It should be noted that positive pole is grounded by IT method in telecom systems in order to minimize the corrosion effect [45]. Installation of grounding system is straightforward in case of TT grounding, and the faults do not migrate [82]. Nevertheless, the high-voltage stress problem still exists and circulating current paths are likely to occur.

Unlike methods presented above, Paul [167] suggests several reconfigurable grounding options with a possibility to operate the system normally in ungrounded mode in order to minimize

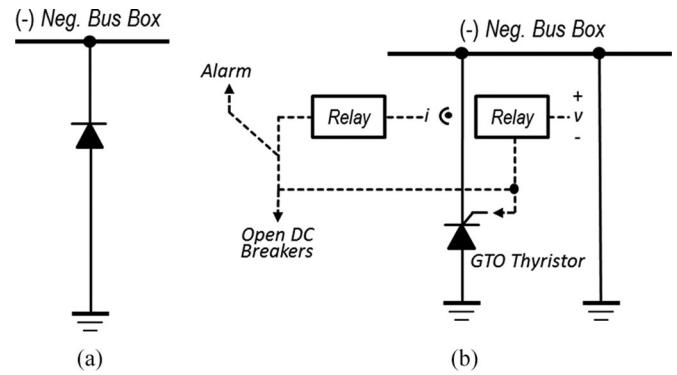

Fig. 12. Block diagrams of reconfigurable grounding systems. (a) Diode grounded system. (b) Thyristor grounded system.

TABLE IV  
SUMMARY OF COMMON-MODE VOLTAGE VERSUS STRAY CURRENT  
RELATIONSHIPS WITH DIFFERENT GROUNDING METHODS

System Grounding Method	Common-Mode Voltage	Stray Current Level
Ungrounded System	High	Low
Solidly Grounded	Low	High
Diode Grounded	Moderate/Low	Moderate/High
Thyristor Grounded	Moderate/High	Moderate/Low

stray-current-induced corrosion, but to automatically ground the system upon sensing dangerously high common-mode voltage. After the clearance of abnormal operating condition is achieved, the system is automatically switched back to ungrounded mode. Block diagrams of two examples of reconfigurable grounding systems, i.e., diode and thyristor grounding, are depicted in Fig. 12.

Diode grounding, as shown in Fig. 12(a), is comprised of a direct metallic connection of the negative portion of dc bus to the ground, but via a diode circuit. In that way, current is allowed to flow from the ground toward the negative bus when the voltage across the diode exceeds some threshold value. Once it happens, it gets dissipated. Since corrosion is not completely eliminated in these kinds of systems, they require a periodical maintenance [178].

Contrary to the diode scheme, bidirectional thyristor scheme offers active control over the grounding instances [see Fig. 12(b)]. This is achieved by triggering the thyristor gate only when the negative-to-ground voltage exceeds a preset value. Moreover, a current sensor is installed in series with the grounding conductor. If the decay of current is observed, it means that the system can be returned to ungrounded mode. On the contrary, if the current would maintain its amplitude, then a positive to ground fault is the most likely reason. In that case, dc feeder breakers are tripped in that case. The status of the system can be communicated with the environment through the alarm signal. The basic advantage of the thyristor grounding strategy is that the system maintains operation in ungrounded mode in every other instance, keeping the stray current minimized [167].

Table IV compares the characteristics of previously described diode and thyristor grounding schemes with respect to their ungrounded and solidly grounded counterparts [167].

### C. Protective Devices

Protection devices that are presently commercially available for dc systems include fuses and circuit breakers (CBs) [45]. However, they inherently introduce large time constants and time delays before activation, respectively. In addition, interruption of the current in both cases is accompanied by the appearance of the arc. While arc gets extinguished naturally in ac systems within the half cycle after tripping by first crossing of the current through zero, it presents a challenge in dc systems since the current has a steady value. Arc occurrence presents a dangerous condition not only from the safety point of view, but also causes contact erosion in CBs and consequently a short lifetime and high maintenance costs [75], [179].

Fuses operate on a principle of melting down the fuse link in a heat absorbing material. Their ratings are specified in terms of RMS values of voltages and currents and are, hence, equally applicable to ac and dc systems. However, it needs to be ensured that the time constant of current increase during the fault is below certain limits since slow increase of temperature may prevent the heat-absorbing material to extinguish the arc [180].

Standard molded-case circuit breakers (MCCB) that consist of a contactor, a quenching chamber, and a tripping device can be used as well. They can have either a thermal–magnetic or electronic tripping device. In either case, sufficient voltage blocking capability can be achieved by connecting contactors in series [45]. One potential problem with MCCBs in systems dominated by power electronic converters, as is the typical case in dc MGs, is that short-circuit currents are supplied mainly by filter capacitors. Their quick discharge following the fault causes currents of very high magnitude, but which last for a very short periods of time. Therefore, the force generated by these currents may be insufficient for opening the contacts of MCCB [75].

Due to inherent tripping time delays and other problems associated with fuses and CBs, protections utilizing only these devices have inherent performance limitations. In order to cope with that, usage of power electronics-based protection devices has been proposed. They are commonly referred to as the solid-state circuit breakers (SSCBs) [181], [182]. Several semiconductor devices, such as gate turn-off thyristors (GTOs), insulated-gate bipolar transistors (IGBTs), and insulated-gate commutated thyristors (IGCTs), have been used in this context, with each one of them having some specific advantages and drawbacks. For that matter, Meyer *et al.* [181] summarizes and compares a number of different switch topologies under technical and economic aspects. It is demonstrated that GTOs and IGCTs have much lower onlosses than IGBTs. Also, it is estimated that IGCT in rectifier configuration has by far the highest reliability.

In order to be able to interrupt the current, there needs to exist an element to which SSCB dissipates energy during interruption. Typical elements installed for that matter are metal–oxide varistors (MOVs), capacitors, and switched resistors or their combinations [182]–[184]. This brings a different perspective of current interruption when compared to conventional breakers where the electric power during tripping the device is manifested in an arc that needs to be extinguished using an arc chute [183], [185].

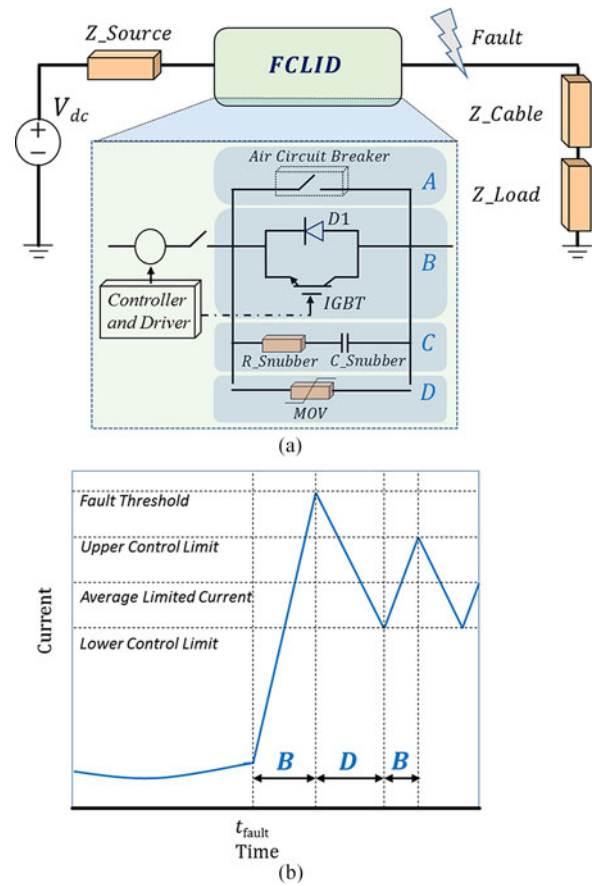

Fig. 13. Fault current limiting and interrupting device [182]. (a) Topology. (b) Fault current waveform.

Exploiting the capability of fast switching, this dedicated power dissipation element can be readily used for current limiting as well. In that sense, SSCBs can actively regulate the fault current to a selected level, rather than leaving it dependent on characteristics of supplying sources. Limited fault current provides less thermal and magnetic stress on the surrounding components resulting in a lower installation cost, as well as safer operation of the system in general [179], [186], [187]. Moreover, current limiting circuits installed at strategic places, e.g., radial line supplying a high power density load center, allow usage of commercially available protection devices with low power rating in the entire downstream network. It should be noted that current limitation functionality can also be achieved by superconducting elements [188]. However, they need to be actively cooled and the current limiting capacity with present technology is inferior to SSCB solutions [187].

A typical example of IGBT-based SSCB with current limiting capability is depicted in Fig. 13(a) [182]. When the semiconductor device (IGBT) switches OFF, the current flowing toward the fault location decays since the power gets dissipated in parallel combination of a snubber circuit and MOV. On the other hand, when the IGBT turns on, the current raises up again. The hysteresis-based controllers with preselected upper and lower thresholds for the fault current are the most commonly deployed to achieve current limiting. An idealized waveform of a current propagation using this kind of controller is shown in Fig. 13(b).

#### D. Design of Protection Systems

The objective of protection system is to detect, locate, and isolate any fault so that the dc MG can continue operating its uncorrupted part. In order to achieve this goal, knowledge about possible faults should be incorporated to select the most appropriate protection devices and grounding methods into a complete protection system. More specifically, desirable characteristics of such a system are reliability, selectivity, speed, performance, economics, and simplicity [75]. In the remainder of this section, several prominent approaches that try to meet these features are summarized.

An insightful example of selecting appropriate protection devices for different components of a dc MG was presented in [45]. According to specific fault withstanding capability of each associated unit, it was concluded that converter protection must be very fast in order to limit the fault current through IGBT diodes, while battery protection can allow slower reaction time as it can withstand considerably higher fault current without damage. For that matter, ultrafast hybrid CB was proposed for converter protection and regular CBs for battery protection. On the other hand, fuses and MCCBs were used for feeder protection. In particular, it was claimed that it is better to use MCCBs closer to the loads since they can simultaneously trip both poles, while fuses are more appropriate for installation closer to the bus due to their magnetic sensing that gives good selectivity. DC-link voltage information together with fault current was used for accurate fault detection.

A handshake method was proposed in [77] to split the dc system into three possible zones and isolate the possible fault on any of the buses. The drawback of this method is that it needs to completely shut down the system following the fault, which may be unnecessary in most conditions. Alternative method that avoids the shutdown was suggested in [82], where a loop-type dc bus was used together with protection that is able to detect the fault and separate only the faulted part, so that the rest of the system keeps operating. The method was realized by using communication system where one master unit receives current measurements from two slave units and gives commands to control the bus switches depending on the difference between the two measured currents. A protection scheme that relies on solid-state converter with fast-acting current-limiting capability was proposed in [189]. The respective converter uses two emitter turn-off devices in antiparallel configuration to realize both switching and protection. Furthermore, a relay-based coordination and backup protection schemes were addressed. Coordination was realized in a fully decentralized fashion, by using appropriate devices such as fuses and diodes.

In [78], consideration of the dynamic characteristics of fault impedances is addressed in detail, giving a motivation to employ a unit protection of dc MGs. For that matter, a flexible design framework for unit protection of dc MGs, which achieves high sensitivity while taking into account a total cost of the system by using commercial of the shelf technologies, is proposed. Moreover, practical limitations of communication technology have been discussed, and it has been shown that better discrimination of faults can be achieved by proposed method.

#### V. STANDARDS AND REGULATION ISSUES ASSOCIATED WITH DC MGs

Although dc MG has been intensively studied in recent years, it is still an emerging technology which needs to face number of challenges before widespread acceptance in industrial and commercial applications. Apart from protection issues discussed in the previous section, standardization is another barrier to proliferation of dc MGs. In order to promote dc MG, several organizations dedicated themselves to develop practical standards. Here, the existing standards and those under development are reviewed and discussed.

European standard ETSI EN 300 132-3-1 discusses the low-voltage dc systems [190]. It is mainly designed for data/telecom equipment with voltage levels of up to 400 V. In normal condition, considering that long power cables may be used, the reference voltage at the input terminal of the equipment is allowed to vary within specified bounds, i.e.,  $365 \pm 15$  V. In abnormal condition, voltage variations, voltage dips, short interruptions, and voltage surges are taken into account. For a certain type of fault, different time durations are specified for fault clearance. Meanwhile, for protection purpose, maximum steady-state current and inrush current are considered. In order to quantify the current limits, pulse time duration  $T_{50}$  is defined, which indicates the time duration when the pulse current exceeds 50% of the peak value. By considering different values of  $T_{50}$ , the limits of pulse current are identified and shown by the ratio between peak pulse current and nominal terminal current. Besides the aspects mentioned above, grounding and electromagnetic compatibility (EMC) requirements are also indicated in this standard.

EMerge Alliance is an open industry association founded recently to promote dc MGs in energy efficient buildings. The vision of EMerge Alliance is to deploy advanced architectures and control systems based on dc MGs in occupied spaces, data/telecom centers, building exteriors, and building services [191]. Except of promoting usage of dc MGs in industrial applications, EMerge Alliance is also working on dc MG standards. Although still under development, the preliminary standards for occupied spaces and data/telecom centers have been released [191]. For occupied spaces, the available power is harvested from conventional ac grid and optional onsite generation such as PV. The main power consumers in the occupied spaces are defined as air conditioners, lightning, wireless internet devices, etc. The dc buses are laid in the ceiling to form the power grid, and daylight sensors are optimally located to rationally adjust the lightning system for energy saving purpose. Apart from occupied spaces, EMerge Alliance also works on standardization of data/telecom centers [191]. Since data/telecom centers as information hubs play an important role in modern society, it is necessary to improve their performance and efficiency. DC MGs can significantly shorten the energy conversion chain from the input side of ac grid to dc end-user and thereby reduce the system power loss. Hence, they become the promising candidates for modern data/telecom centers. AC power is rectified to 380 V dc power to supply various components in data/telecom center, e.g., racks and servers,

while dc UPS is deployed to guarantee reliable power generation.

IEEE Standard 946 provides the recommended practice for dc auxiliary power systems [192]. Rather than being customized for dc MG, it was originally designed for battery-based dc auxiliary power systems for generation stations [193]. However, some of the content of this standard also applies to dc MGs nowadays. It normalizes the design and operation of lead acid batteries in dc power systems. Sizing of batteries, determination of battery duty cycles, maintenance, testing, and replacement are included. Meanwhile, technical specifications of battery chargers are also discussed. For example, in order to ensure safe operation of the battery, the output voltage ripple is limited to 2% of the nominal value without additional filtering. Typical system architecture of a dc distribution system is also shown in this standard, and the detailed voltage rating of each component is listed.

IEC SG4 has established a dedicated technical committee in charge of delivering standards for LVDC distribution systems of up to 1500 V [194]. The objective is to coordinate the standardization of different areas where LVDC distribution systems are used, e.g., data centers, commercial buildings, electricity storage for mobile products, EVs, etc. IEC SG4 also focuses on market needs to effectively promote LVDC systems into practical applications. By considering these requirements, energy efficiency, reduction of EMC issues, and reduced usage of natural resources are taken into account. Meanwhile, measuring methods, protection, and grounding issues are discussed. Finally, a dc-powered green home is proposed where PV or wind power are used as the energy input, and the heating ventilation air conditioning system is energized by dc power.

Recently formed IEEE DC@Home committee sponsored by the IEEE PES Intelligent Grid Coordinating Committee has also gathered some of the leading experts in the dc MG area to cooperate in developing the standards and defining the roadmap for research and commercialization of dc MGs [195]. The goal of DC@Home committee is to 1) create a business case for dc by determining the actual energy losses; 2) identify research required to advance the state of the art; 3) make preliminary recommendations on how dc would be delivered into the homes; and 4) determine the standards that should be followed.

REbus is an open standard that proposes the normalized operation of dc MG for both residential and commercial applications [85]. REbus dc MG operates alongside existing ac utility grid, and coordinates the operation of hybrid onsite renewable energy generation. Communication layers are included to enable system level energy management and monitor the status of each unit in dc MG. Based on REbus standard, the nominal dc bus voltage is 380 V. However, for decentralized coordination of purposes of primary source units, loads and ESSs, this voltage level can be changed within the specified range.

Apart from the aforementioned standards, some other works can be also used for standardizing the operation of dc MG. For example, National Electrical Code (NEC) includes articles and clauses introducing the utilization of dc technology [193]. For instance, military standard MIL-STD-1399 includes sections defining the requirements of dc equipment in shipboard power systems [193], [196]. Table V summarizes the general descrip-

tions and scopes of the standards mentioned in this section [193], [195], [197].

Finally, it should be noted that the IEEE Standard 1547 can also be used to normalize the operation of dc MGs. Although it is designed for ac distribution system with RESs, some of the concepts in it can be employed in dc systems and thereby used for expansion into standards for dc MGs. This standard covers different operation modes of MGs, i.e., grid-connected and islanding operation modes. Meanwhile, requirements for both normal and abnormal conditions are discussed. Section 4 in the given standard introduces the interconnection technical specifications and requirements, and is being regarded as the fundamental standardization guideline for MGs [197], [198]. It normalizes not only the operation in normal condition, e.g., voltage regulation and synchronization, but also the responses when distributed sources encounter faults. Detailed requirements of acceptable voltage and frequency ranges are given to quantify the response of protective devices. Power quality issues are also within the scope, including dc injection, harmonics, etc.

Among the standardization topics from different organizations, a common concern is the general consensus about the optimal voltage level for dc MG. At present, the most likely option seems to be 380 V as the rated voltage level, especially for household and data/telecom center applications. On the other hand, 48- or 24-V dc voltages can be commonly selected as auxiliary dc voltage levels for low-voltage rating appliances. For instance, in dc nanogrid proposed by the Virginia Polytechnic University [18], hybrid voltage levels of 380 and 48 V coexist to meet the requirements of different appliances in the house. However, different voltage levels have also been selected. For example, a 1500-V dc MG is built up in Finland [199], while a bipolar dc MG proposed in Japan, uses  $\pm 170$  V [20].

## VI. CONCLUSION AND FUTURE TRENDS

This paper has summarized the state of the art in hardware topologies and applications of dc MGs, together with practical concerns regarding their wide-scale deployment. Several types of prominent hardware topologies are presented before continuing with assessment of their suitability for practical applications, such as dc households, EV charging stations, hybrid ESSs, and RES parks. Regarding the hardware topologies, the common industrial approach based on direct connection of battery stack to the common dc bus can be replaced by more flexible structures which include regulated bus.

As an extension to singular bus structure, redundant bus topologies have been proposed as attractive solutions in case when highly reliable distribution is required. More recently, SST has been recognized as a key enabling technology not only for dc MGs, but also for future dc distribution systems in general. However, more development related to this technology needs to be done before it enters the SG.

Practical performance requirements of four typical dc MG applications, i.e., efficient households, renewable energy parks, hybrid ESSs, and fast dc EV charging stations, have been discussed. In that sense, a critical opinion about the usefulness of functionalities such as redundancy, flexibility, scalability,

TABLE V  
GENERAL DESCRIPTIONS AND SCOPES OF DC STANDARDS

Standard	Description	Scope
1 ETSI EN 300 132-3-1	Power supply interface at the input to data/telecom equipment Subpart 1 of Part 3: Direct current source up to 400 V	<ul style="list-style-type: none"> <li>• Designed for data/telecom equipment</li> <li>• For voltage levels of up to 400 V</li> <li>• Consider voltage level in normal operation and requirements for different types of abnormal operation</li> <li>• Limit of fault current</li> <li>• Grounding and EMC</li> </ul>
2 EMerge Alliance dc MG	Standards for occupied spaces and data center	<ul style="list-style-type: none"> <li>• Recommended architecture and control system in dc MGs</li> </ul>
3 IEEE 946	Recommended practice for the design of dc auxiliary power systems for generating stations	<ul style="list-style-type: none"> <li>• Recommended practice of lead-acid-battery-based dc auxiliary power systems for generation stations</li> <li>• Normalize the operation regarding batteries, e.g., sizing, determination of duty cycle, maintenance, etc.</li> <li>• Technical specifications of battery chargers</li> <li>• Typical architecture of dc systems</li> <li>• Voltage ratings of dc equipment</li> </ul>
4 IEC SG4	LVDC distribution system up to 1500V	<ul style="list-style-type: none"> <li>• Coordinate the standardization of different areas, e.g., data centers, commercial buildings, etc.</li> <li>• Energy efficiency, EMC, reduction of natural resources</li> <li>• 100% dc or hybrid ac and dc architecture</li> <li>• Life cycle of equipment, protection and grounding</li> </ul>
5 IEEE DC@Home	DC-powered house	<ul style="list-style-type: none"> <li>• Standard and roadmap of applying LVDC MG in residential houses</li> </ul>
6 REbus	Open standard for clean power distribution relying on dc	<ul style="list-style-type: none"> <li>• Evaluation of losses using dc power at home</li> <li>• Operate alongside with existing ac system</li> <li>• Hybrid coordination of on-site renewable energy generation</li> <li>• 380 V dc common bus with acceptable variation based on the status of source, load and energy storage</li> </ul>
7 NEC	Legal codes including introduction of dc technology	<ul style="list-style-type: none"> <li>• Article 393, 625, 690, 692 introduce dc technology</li> </ul>
8 MIL-STD-1399	Electrical interface characteristics for shipboard equipment	<ul style="list-style-type: none"> <li>• Includes sections defining the requirements of dc equipment in shipboard power systems</li> </ul>
9 IEEE 1547	Requirements for interconnecting distributed resources with electric power systems	<ul style="list-style-type: none"> <li>• Designed for ac system and some of its contents can be used as a reference when designing the standards for dc systems</li> <li>• Islanding and grid-connected operation modes</li> <li>• Normal and abnormal operation</li> <li>• Requirements and practice for distributed sources</li> </ul>

coordinated control, and grid support capability has been given. Moreover, elaboration about possibility to achieve the proposed performance specification within the framework of available architectures and control strategies has been presented together with several examples for each application.

Finally, the state of the art in protection and standardization for dc MGs has been presented. Regarding protection, basic protection principles and grounding methods have been explained within the framework of available devices. This has been followed by a critical evaluation of several newly proposed protection systems. Regarding regulation issues, it has been pointed out that the key prerequisite for true large-scale integration of low-voltage dc distribution networks into the SG is adoption of corresponding standards. In that sense, IEEE 1547 is the suitable standard for ac MGs, but only parts of it can be used for dc MGs. Therefore, dedicated standards for normalizing the operation of dc MGs are highly required. For that matter, standards such as EMerge Alliance, IEC SG4, and IEEE DC@Home and REbus are under development. This paper has addressed the current status and future development directions for each one of them. On the other hand, ETSI EN 300 132-3-1, IEEE 946, NEC, and MIL-STD-1399 are already established and the number of concepts used in them can be already directly used.

Given the increasing penetration of RESs and electronically regulated loads in modern distribution networks, it is foreseeable that dc MGs will continue to be rapidly developed in the following years. Referencing to the topics covered in this manuscript, several key lines of future research can be pointed out. First of all, a lot of attention will need to be devoted to still unresolved practical issues associated with dc systems, i.e., protection and grounding schemes. For that matter, design of fast acting dc breakers and grounding devices based on solid-state technology with current limiting capability will continue to be a very important research topic. As is customary, objective will be to achieve extended functionalities with more compact design and higher reliability. Moreover, coordinated integration of these kinds of devices into overall protection systems is envisioned to be a fertile ground for researchers in the nearest future. On the other hand, new and improved converter topologies will be developed for interfacing different types of sources or ac grids with dc MGs. Finally, the applications of dc MGs will be extended to a large extent. In particular, penetration of medium voltage dc distribution systems into practical industrial applications is expected to experience rapid growth in near future, both for autonomous and grid-connected applications. This expansion will naturally lead to proposals of new hardware architectures

and alternative arrangements of the common dc bus for higher reliability and redundancy.

## REFERENCES

- [1] W. A. Tabisz, M. Jovanovic, and F. C. Lee, "Present and future of distributed power systems," in *Proc. Appl. Power Electron. Conf. Expo.*, 1992, pp. 11–18.
- [2] S. Schulz, B. H. Cho, and F. C. Lee, "Design considerations for a distributed power system," in *Proc. IEEE Annu. Power Electron. Spec. Conf.*, 1990, pp. 611–617.
- [3] B. K. Johnson, R. H. Lasseter, F. L. Alvarado, and R. Adapa, "Expandable multiterminal DC system based on voltage droop," *IEEE Trans. Power Del.*, vol. 8, no. 4, pp. 1926–1932, Oct. 1993.
- [4] J. S. Glaser and A. F. Witulski, "Output plane analysis of load-sharing in multiple-module converter systems," *IEEE Trans. Power Electron.*, vol. 9, no. 1, pp. 43–50, Jan. 1994.
- [5] S. Luo, Z. Ye, R.-L. Lin, and F. C. Lee, "A classification and evaluation of paralleling methods for power supply modules," in *Proc. IEEE Annu. Power Electron. Spec. Conf.*, 1999, vol. 2, pp. 901–908.
- [6] I. Batarseh, K. Siri, and H. Lee, "Investigation of the output droop characteristics of parallel-connected DC–DC converters," in *Proc. IEEE Annu. Power Electron. Spec. Conf.*, 1994, pp. 1342–1351.
- [7] R. D. Middlebrook, "Input filter considerations in design and application of switching regulators," in *Proc. IEEE Ind. Appl. Soc. Annu. Meet.*, 1976, pp. 366–382.
- [8] G. S. Thandi, R. Zhang, K. Xing, F. C. Lee, and D. Boroyevich, "Modeling, control and stability analysis of a PEBB based DC DPS," *IEEE Trans. Power Del.*, vol. 14, no. 2, pp. 497–505, Apr. 1999.
- [9] C. M. Wildrick, F. C. Lee, B. H. Cho, and B. Choi, "A method of defining the load impedance specification for a stable distributed power system," *IEEE Trans. Power Electron.*, vol. 10, no. 3, pp. 280–285, May 1995.
- [10] M. Belkhat, R. Cooley, and A. Witulski, "Large signal stability criteria for distributed systems with constant power loads," in *Proc. IEEE Annu. Power Electron. Spec. Conf.*, 1995, vol. 2, pp. 1333–1338.
- [11] K. M. Mistry, E. Silverman, T. Taylor, and R. Willis, "Telecommunications power architectures: Distributed or centralized," presented at the Int. Telecommunication Energy Conf., Florence, Italy, 1989.
- [12] T. M. Gruz and J. Hall, "AC, DC or hybrid power solutions for today's telecommunications facilities," in *Proc. Int. Telecommun. Energy Conf.*, 2000, pp. 361–368.
- [13] F. Bodi, "DC-grade reliability for UPS in telecommunications data centers," in *Proc. Int. Telecommun. Energy Conf.*, 2007, pp. 595–602.
- [14] A. Kwasinski, "Quantitative evaluation of DC microgrids availability: Effects of system architecture and converter topology design choices," *IEEE Trans. Power Electron.*, vol. 26, no. 3, pp. 835–851, Mar. 2011.
- [15] G. AlLee and W. Tschudi, "Edison redux: 380 Vdc brings reliability and efficiency to sustainable data centers," *IEEE Power Energy Mag.*, vol. 10, no. 6, pp. 50–59, Nov./Dec. 2012.
- [16] A. Emadi, M. Ehsani, and J. M. Miller, *Vehicular Electric Power System: Land, Sea, Air, and Space Vehicles*. New York, NY, USA: Taylor & Francis, 2010.
- [17] A. Emadi, Y. J. Lee, and K. Rajashekara, "Power electron and motor drives in electric, hybrid electric, and plug-in hybrid electric vehicles," *IEEE Trans. Ind. Electron.*, vol. 55, no. 6, pp. 2237–2245, Jun. 2008.
- [18] D. Boroyevich, I. Cvetkovic, D. Dong, R. Burgos, F. Wang, and F. Lee, "Future electronic power distribution systems: A contemplative view," in *Proc. Int. Conf. Opt. Electr. Electron. Equip.*, 2010, pp. 1369–1380.
- [19] T. Dragicevic, J. C. Vasquez, J. M. Guerrero, and D. Skrlac, "Advanced LVDC electrical power architectures and microgrids: A step toward a new generation of power distribution networks," *IEEE Electr. Mag.*, vol. 2, no. 1, pp. 54–65, Mar. 2014.
- [20] H. Kakigano, Y. Miura, and T. Ise, "Low-voltage bipolar-type DC microgrid for super high quality distribution," *IEEE Trans. Power Electron.*, vol. 25, no. 12, pp. 3066–3075, Dec. 2010.
- [21] D. Dong, I. Cvetkovic, D. Boroyevich, W. Zhang, R. Wang, and P. Mattavelli, "Grid-interface bidirectional converter for residential DC distribution systems-part one: High-density two-stage topology," *IEEE Trans. Power Electron.*, vol. 28, no. 4, pp. 1655–1666, Apr. 2013.
- [22] D. Dong, F. Luo, X. Zhang, D. Boroyevich, and P. Mattavelli, "Grid-interface bidirectional converter for residential DC distribution systems-part two: AC and DC interface design with passive components minimization," *IEEE Trans. Power Electron.*, vol. 28, no. 4, pp. 1667–1679, Apr. 2013.
- [23] T. Dragicevic, S. Susic, J. C. Vasquez, and J. M. Guerrero, "Flywheel-based distributed bus signaling strategy for the public fast charging station," *IEEE Trans. Smart Grid*, vol. 5, no. 6, pp. 2825–2835, Nov. 2014.
- [24] S. Bai and S. M. Lukic, "Unified Active filter and energy storage system for a MW electric vehicle charging station," *IEEE Trans. Power Electron.*, vol. 28, no. 12, pp. 5793–5803, Dec. 2013.
- [25] S. Rivera, B. Wu, S. Kouro, V. Yaramasu, and J. Wang, "Electric vehicle charging station using a neutral point clamped converter with bipolar DC bus," *IEEE Trans. Ind. Electron.*, vol. 62, no. 4, pp. 1999–2009, Apr. 2015.
- [26] K. Clement-Nyns, E. Haesen, and J. Driesen, "The impact of charging plug-in hybrid electric vehicles on a residential distribution grid," *IEEE Trans. Power Syst.*, vol. 25, no. 1, pp. 371–380, Feb. 2010.
- [27] K. Kim, T. Yoon, G. Byeon, H. Jung, H. Kim, and G. Jang, "Power demand and power quality analysis of EV charging station using BESS in MicroGrid," in *Proc. IEEE Veh. Power Propul. Conf.*, 2012, pp. 996–1001.
- [28] Y. Du, X. Zhou, S. Bai, S. Lukic, and A. Huang, "Review of non-isolated bi-directional DC-DC converters for plug-in hybrid electric vehicle charge station application at municipal parking decks," in *Proc. IEEE Annu. Appl. Power Electron. Conf. Expo.*, 2010, pp. 1145–1151.
- [29] S. Jung, H. Lee, C. S. Song, J.-H. Han, W.-K. Han, and G. Jang, "Optimal operation plan of the online electric vehicle system through establishment of a DC distribution system," *IEEE Trans. Power Electron.*, vol. 28, no. 12, pp. 5878–5889, Dec. 2013.
- [30] J. Cao and A. Emadi, "A new battery/ultracapacitor hybrid energy storage system for electric, hybrid, and plug-in hybrid electric vehicles," *IEEE Trans. Power Electron.*, vol. 27, no. 1, pp. 122–132, Jan. 2012.
- [31] H. Zhou, T. Bhattacharya, D. Tran, T. S. T. Siew, and A. M. Khambadkone, "Composite energy storage system involving battery and ultracapacitor with dynamic energy management in microgrid appl," *IEEE Trans. Power Electron.*, vol. 26, no. 3, pp. 923–930, Mar. 2011.
- [32] Z. Ding, C. Yang, Z. Zhang, C. Wang, and S. Xie, "A novel soft-switching multiport bidirectional DC-DC converter for hybrid energy storage system," *IEEE Trans. Power Electron.*, vol. 29, no. 4, pp. 1595–1609, Apr. 2014.
- [33] B. Hredzak, V. G. Agelidis, and M. Jang, "A model predictive control system for a hybrid battery-ultracapacitor power source," *IEEE Trans. Power Electron.*, vol. 29, no. 3, pp. 1469–1479, Mar. 2014.
- [34] T. Ise, M. Kita, and A. Taguchi, "A hybrid energy storage with a SMES and secondary battery," *IEEE Trans. Appl. Supercond.*, vol. 15, no. 2, pp. 1915–1918, Jun. 2005.
- [35] Z. Jiang and R. A. Dougal, "A compact digitally controlled fuel cell/battery hybrid power source," *IEEE Trans. Ind. Electron.*, vol. 53, no. 4, pp. 1094–1104, Jun. 2006.
- [36] Z. Zhang, Z. Ouyang, O. C. Thomsen, and M. A. E. Andersen, "Analysis and design of a bidirectional isolated DC-DC converter for fuel cells and supercapacitors hybrid system," *IEEE Trans. Power Electron.*, vol. 27, no. 2, pp. 848–859, Feb. 2012.
- [37] C. Meyer, M. Hoing, A. Peterson, and R. W. De Doncker, "Control and design of DC grids for offshore wind farms," *IEEE Trans. Ind. Appl.*, vol. 43, no. 6, pp. 1475–1482, Nov./Dec. 2007.
- [38] J. Robinson, D. Jovicic, and G. Joos, "Analysis and design of an offshore wind farm using a MV DC grid," *IEEE Trans. Power Del.*, vol. 25, no. 4, pp. 2164–2173, Oct. 2010.
- [39] M. M. Amin and O. A. Mohammed, "Design and implementation of DC-bus system module for parallel integrated sustainable energy conversion systems," in *Proc. IEEE Power Energy Soc. Gen. Meet.*, 2011, pp. 1–8.
- [40] H. Valderrama-Blavi, J. M. Bosque, F. Guinjoan, L. Marroyo, and L. Martinez-Salamero, "Power adaptor device for domestic DC microgrids based on commercial MPPT inverters," *IEEE Trans. Ind. Electron.*, vol. 60, no. 3, pp. 1191–1203, Mar. 2013.
- [41] T.-F. Wu, J. Yang, L.-C. Lin, and Y. Chen, "Design and implementation of multiple maximum power point trackers for multi-string PV panels in DC distribution systems," in *Proc. IEEE Annu. Appl. Power Electron. Conf. Expo.*, 2012, pp. 563–567.
- [42] R. Adda, O. Ray, S. K. Mishra, and A. Joshi, "Synchronous-reference-frame-based control of switched boost inverter for standalone DC nanogrid applications," *IEEE Trans. Power Electron.*, vol. 28, no. 3, pp. 1219–1233, Mar. 2013.
- [43] S.-M. Chen, T.-J. Liang, and K.-R. Hu, "Design, analysis, and implementation of solar power optimizer for DC distribution system," *IEEE Trans. Power Electron.*, vol. 28, no. 4, pp. 1764–1772, Apr. 2013.
- [44] A. Pratt, P. Kumar, and T. V. Aldridge, "Evaluation of 400V DC distribution in telco and data centers to improve energy efficiency," in *Proc. Int. Telecommun. Energy Conf.*, 2007, pp. 32–39.

- [45] D. Salomonsson, L. Soder, and A. Sannino, "Protection of low-voltage DC microgrids," *IEEE Trans. Power Del.*, vol. 24, no. 3, pp. 1045–1053, Jul. 2009.
- [46] V. Nasirian, S. Moayedi, A. Davoudi, and F. Lewis, "Distributed cooperative control of DC microgrids," *IEEE Trans. Power Electron.*, vol. 30, no. 4, pp. 2288–2303, Apr. 2015.
- [47] C. Wang, X. Li, L. Guo, and Y. W. Li, "A nonlinear-disturbance-observer-based DC-bus voltage control for a hybrid AC/DC microgrid," *IEEE Trans. Power Electron.*, vol. 29, no. 11, pp. 6162–6177, Nov. 2014.
- [48] X. Lu, J. M. Guerrero, K. Sun, and J. C. Vasquez, "An improved droop control method for DC microgrids based on low bandwidth communication with DC bus voltage restoration and enhanced current sharing accuracy," *IEEE Trans. Power Electron.*, vol. 29, no. 4, pp. 1800–1812, Apr. 2014.
- [49] N. L. Diaz, T. Dragicevic, J. C. Vasquez, and J. M. Guerrero, "Intelligent distributed generation and storage units for DC microgrids—A new concept on cooperative control without communications beyond droop control," *IEEE Trans. Smart Grid*, vol. 5, no. 5, pp. 2476–2485, Sep. 2014.
- [50] S. Anand, B. G. Fernandes, and J. M. Guerrero, "Distributed control to ensure proportional load sharing and improve voltage regulation in low-voltage DC microgrids," *IEEE Trans. Power Electron.*, vol. 28, no. 4, pp. 1900–1913, Apr. 2013.
- [51] X. She, A. Q. Huang, S. Lukic, and M. E. Baran, "On integration of solid-state transformer with zonal DC microgrid," *IEEE Trans. Smart Grid*, vol. 3, no. 2, pp. 975–985, Jun. 2012.
- [52] A. A. A. Radwan and Y. A.-R. I. Mohamed, "Linear active stabilization of converter-dominated DC microgrids," *IEEE Trans. Smart Grid*, vol. 3, no. 1, pp. 203–216, Mar. 2012.
- [53] L. Meng, J. C. Vasquez, J. M. Guerrero, and T. Dragicevic, "Agent-based distributed hierarchical control of DC microgrid systems," in *Proc. ElectrIMACS Conf.*, 2014, pp. 281–286.
- [54] R. S. Balog and P. T. Krein, "Bus selection in multibus DC microgrids," *IEEE Trans. Power Electron.*, vol. 26, no. 3, pp. 860–867, Mar. 2011.
- [55] T. Dragicevic, J. M. Guerrero, J. C. Vasquez, and D. Skrllec, "Supervisory control of an adaptive-droop regulated DC microgrid with battery management capability," *IEEE Trans. Power Electron.*, vol. 29, no. 2, pp. 695–706, Feb. 2014.
- [56] R. H. Lasseter, "MicroGrids," in *Proc. IEEE Power Eng. Soc. Winter Meet. Conf.*, 2002, vol. 1, pp. 305–308.
- [57] T. Ackermann, G. Andersson, and L. Söder, "Distributed generation: A definition," *Electr. Power Syst. Res.*, vol. 57, no. 3, pp. 195–204, 2001.
- [58] J.-F. Chen and C.-L. Chu, "Combination voltage-controlled and current-controlled PWM inverters for UPS parallel operation," *IEEE Trans. Power Electron.*, vol. 10, no. 5, pp. 547–558, Sep. 1995.
- [59] E. A. A. Coelho, P. C. Cortizo, and P. F. D. Garcia, "Small-signal stability for parallel-connected inverters in standalone AC supply system," *IEEE Trans. Ind. Appl.*, vol. 38, no. 2, pp. 533–542, Mar./Apr. 2002.
- [60] J. M. Guerrero, L. Hang, and J. Uceda, "Control of distributed uninterruptible power supply system," *IEEE Trans. Ind. Electron.*, vol. 55, no. 8, pp. 2845–2859, Aug. 2008.
- [61] K. De Brabandere, B. Bolsens, J. den Keybus, A. Woyte, J. Driesen, and R. Belmans, "A voltage and frequency droop control method for parallel inverters," *IEEE Trans. Power Electron.*, vol. 22, no. 4, pp. 1107–1115, Jul. 2007.
- [62] J. M. Guerrero, L. G. De Vicuña, J. Matas, M. Castilla, and J. Miret, "A wireless controller to enhance dynamic performance of parallel inverters in distributed generation systems," *IEEE Trans. Power Electron.*, vol. 19, no. 5, pp. 1205–1213, Sep. 2004.
- [63] Y. Ito, Z. Yang, and H. Akagi, "DC microgrid based distribution power generation system," in *Proc. Power Electron. Motion Control Conf.*, 2004, vol. 3, pp. 1740–1745.
- [64] A. Kwasinski and P. T. Krein, "A microgrid-based telecom power system using modular multiple-input DC-DC converters," in *Proc. Int. Telecommun. Conf.*, 2005, pp. 515–520.
- [65] H. Kakigano, Y. Miura, T. Ise, and R. Uchida, "DC Micro-grid for super high quality distribution—System configuration and control of distributed generations and energy storage devices," in *Proc. IEEE Power Electron. Spec. Conf.*, 2006, pp. 1–7.
- [66] D. Salomonsson, L. Soder, and A. Sannino, "An adaptive control system for a DC microgrid for data centers," *IEEE Trans. Ind. Appl.*, vol. 44, no. 6, pp. 1910–1917, Nov./Dec. 2008.
- [67] P. Biczal, "Power electronic converters in DC microgrid," in *Proc. Compat. Power Electron.*, 2007, pp. 1–6.
- [68] Autonomous power supply system—Končar Hybrid Box. (2014). [Online]. Available: [http://www.koncar-institut.com/solutions/autonomous\\_hybrid\\_power\\_supply](http://www.koncar-institut.com/solutions/autonomous_hybrid_power_supply).
- [69] Schneider-Electric: Solar rural electrification for communities. (2015). [Online]. Available: <http://solar.schneider-electric.com/solution/residential-community-electrification/>.
- [70] T. Dragicevic, "Hierarchical control of a direct current microgrid with energy storage systems in a distributed topology," Ph.D. Dissertation, Faculty Elect. Eng. Comput., Zagreb Univ., Zagreb, Croatia, 2013.
- [71] S. P. Engel, N. Soltan, H. Stagege, and R. W. De Doncker, "Dynamic and balanced control of three-phase high-power dual-active bridge DC-DC converters in DC-grid applications," *IEEE Trans. Power Electron.*, vol. 28, no. 4, pp. 1880–1889, Apr. 2013.
- [72] R. W. De Doncker, "Power electronic technologies for flexible DC distribution grids," in *Proc. Int. Power Electron. Conf.*, 2014, pp. 736–743.
- [73] N. C. Ekneligoda and W. W. Weaver, "A game theoretic bus selection method for loads in multibus DC power systems," *IEEE Trans. Ind. Electron.*, vol. 61, no. 4, pp. 1669–1678, Apr. 2014.
- [74] Q. Shafiee, T. Dragicevic, J. C. Vasquez, and J. M. Guerrero, "Hierarchical control for multiple DC-microgrids clusters," *IEEE Trans. Energy Convers.*, vol. 29, no. 4, pp. 922–933, Dec. 2014.
- [75] R. M. Cuzner and G. Venkataramanan, "The status of DC microgrid protection," in *Proc. IEEE Ind. Appl. Soc. Annu. Meet.*, 2008, pp. 1–8.
- [76] M. Saeedifard, M. Graovac, R. F. Dias, and R. Iravani, "DC power systems: Challenges and opportunities," in *Proc. IEEE Power Energy Soc. Gen. Meet.*, 2010, pp. 1–7.
- [77] L. Tang and B.-T. Ooi, "Locating and isolating DC faults in multi-terminal DC systems," *IEEE Trans. Power Del.*, vol. 22, no. 3, pp. 1877–1884, Jul. 2007.
- [78] S. D. A. Fletcher, P. J. Norman, S. J. Galloway, P. Crolla, and G. M. Burt, "Optimizing the roles of unit and non-unit protection methods within DC microgrids," *IEEE Trans. Smart Grid*, vol. 3, no. 4, pp. 2079–2087, Dec. 2012.
- [79] K. Corzine, "DC microgrid protection with the Z-source breaker," in *Proc. IEEE Annu. Conf. Ind. Electron. Soc.*, 2013, pp. 2197–2204.
- [80] S. R. B. Vanteddu, A. Mohamed, and O. Mohammed, "Protection design and coordination of DC distributed power systems architectures," in *Proc. IEEE Power Energy Soc. Gen. Meet.*, 2013, pp. 1–5.
- [81] J.-D. Park, J. Candelaria, L. Ma, and K. Dunn, "DC ring-bus microgrid fault protection and identification of fault location," *IEEE Trans. Power Del.*, vol. 28, no. 4, pp. 2574–2584, Oct. 2013.
- [82] J.-D. Park and J. Candelaria, "Fault detection and isolation in low-voltage DC-bus microgrid system," *IEEE Trans. Power Del.*, vol. 28, no. 2, pp. 779–787, Apr. 2013.
- [83] S. D. A. Fletcher, P. J. Norman, K. Fong, S. J. Galloway, and G. M. Burt, "High-speed differential protection for smart DC distribution systems," *IEEE Trans. Smart Grid*, vol. 5, no. 5, pp. 2610–2617, Sep. 2014.
- [84] A. A. S. Enhemed and G. M. Burt, "An advanced protection scheme for enabling an LVDC last mile distribution network," *IEEE Trans. Smart Grid*, vol. 5, no. 5, pp. 2602–2609, Sep. 2014.
- [85] REBUS DC microgrid. (2013). [Online]. Available: <http://rebuspower.com/technical.shtml>
- [86] Arcola energy DC microgrid. (2015). [Online]. Available: <http://arcolaenergy.com/pages/dc-microgrid>
- [87] Elecyr DC microgrids. (2008). [Online]. Available: <http://www.hybridpropulsion.com/>
- [88] SPIDERS: The smart power infrastructure demonstration for energy reliability and security. (2012). [Online]. Available: [http://energy.sandia.gov/wp-content/gallery/uploads/SPIDERS\\_Fact\\_Sheet\\_2012-1431P.pdf](http://energy.sandia.gov/wp-content/gallery/uploads/SPIDERS_Fact_Sheet_2012-1431P.pdf)
- [89] F. Valenciaga and P. F. Puleston, "Supervisor control for a standalone hybrid generation system using wind and photovoltaic energy," *IEEE Trans. Energy Convers.*, vol. 20, no. 2, pp. 398–405, Jun. 2005.
- [90] A. M. Knight and G. E. Peters, "Simple wind energy controller for an expanded operating range," *IEEE Trans. Energy Convers.*, vol. 20, no. 2, pp. 459–466, Jun. 2005.
- [91] F. Valenciaga and P. F. Puleston, "High-order sliding control for a wind energy converters. System based on a permanent magnet synchronous generator," *IEEE Trans. Energy Convers.*, vol. 23, no. 3, pp. 860–867, Sep. 2008.
- [92] S. J. Chiang, H.-J. Shieh, and M.-C. Chen, "Modeling and control of PV charger system with SEPIC converter," *IEEE Trans. Ind. Electron.*, vol. 56, no. 11, pp. 4344–4353, Nov. 2009.

- [93] P. Lindman and L. Thorsell, "Applying distributed power modules in telecom systems," *IEEE Trans. Power Electron.*, vol. 11, no. 2, pp. 365–373, Mar. 1996.
- [94] "TS-MPPT-60, Solar System Controller," 2013.
- [95] J.-W. Kim, H.-S. Choi, and B. H. Cho, "A novel droop method for converter parallel operation," *IEEE Trans. Power Electron.*, vol. 17, no. 1, pp. 25–32, Jan. 2002.
- [96] R. Ayyanar, R. Giri, and N. Mohan, "Active input-voltage and load-current sharing in input-series and output-parallel connected modular DC-DC converters using dynamic input-voltage reference scheme," *IEEE Trans. Power Electron.*, vol. 19, no. 6, pp. 1462–1473, Nov. 2004.
- [97] D. Sha, Z. Guo, and X. Liao, "Cross-feedback output-current-sharing control for input-series-output-parallel modular DC-DC converters," *IEEE Trans. Power Electron.*, vol. 25, no. 11, pp. 2762–2771, Nov. 2010.
- [98] P. Liutanakul, A.-B. Awan, S. Pierfederici, B. Nahid-Mobarakkeh, and F. Meibody-Tabar, "Linear stabilization of a DC bus supplying a constant power load: A general design approach," *IEEE Trans. Power Electron.*, vol. 25, no. 2, pp. 475–488, Feb. 2010.
- [99] A. Kwasinski and C. N. Onwuchekwa, "Dynamic behavior and stabilization of DC microgrids with instantaneous constant-power loads," *IEEE Trans. Power Electron.*, vol. 26, no. 3, pp. 822–834, Mar. 2011.
- [100] P. Karlsson and J. Svensson, "DC bus voltage control for a distributed power system," *IEEE Trans. Power Electron.*, vol. 18, no. 6, pp. 1405–1412, Nov. 2003.
- [101] J. Schonberger, R. Duke, and S. D. Round, "DC-bus signaling: A distributed control strategy for a hybrid renewable nanogrid," *IEEE Trans. Ind. Electron.*, vol. 53, no. 5, pp. 1453–1460, Oct. 2006.
- [102] K. Sun, L. Zhang, Y. Xing, and J. M. Guerrero, "A distributed control strategy based on DC bus signaling for modular photovoltaic generation systems with battery energy storage," *IEEE Trans. Power Electron.*, vol. 26, no. 10, pp. 3032–3045, Oct. 2011.
- [103] T. Dragicevic, J. M. Guerrero, and J. C. Vasquez, "A distributed control strategy for coordination of an autonomous lvdc microgrid based on power-line signaling," *IEEE Trans. Ind. Electron.*, vol. 61, no. 7, pp. 3313–3326, Jan. 2014.
- [104] Q. Shafiee, T. Dragicevic, J. C. Vasquez, and J. M. Guerrero, "Modeling, stability analysis and active stabilization of multiple DC microgrid clusters," in *Proc. IEEE Int. Energy Conf.*, 2014, pp. 1284–1290.
- [105] X. She, A. Q. Huang, and R. Burgos, "Review of solid-state transformer technologies and their application in power distribution systems," *IEEE J. Emerg. Sel. Topics Power Electron.*, vol. 1, no. 3, pp. 186–198, Sep. 2013.
- [106] A. Q. Huang, M. L. Crow, G. T. Heydt, J. P. Zheng, and S. J. Dale, "The future renewable electric energy delivery and management (FREEDM) system: The energy internet," *Proc. IEEE*, vol. 99, no. 1, pp. 133–148, Jan. 2011.
- [107] S. Bifaretti, P. Zanchetta, A. Watson, L. Tarisciotti, and J. C. Clare, "Advanced power electronic conversion and control system for universal and flexible power management," *IEEE Trans. Smart Grid*, vol. 2, no. 2, pp. 231–243, Jun. 2011.
- [108] M. Liserre. HEART—The highly efficient and reliable smart transformer. (2015). [Online]. Available: [http://www.pe.tf.uni-kiel.de/en/staff/professors/prof.-dr.-ing.-marco-liserre/presentation\\_sonderborg](http://www.pe.tf.uni-kiel.de/en/staff/professors/prof.-dr.-ing.-marco-liserre/presentation_sonderborg)
- [109] N. R. Chaudhuri, R. Majumder, and B. Chaudhuri, "System frequency support through multi-terminal DC (MTDC) Grids," *IEEE Trans. Power Syst.*, vol. 28, no. 1, pp. 347–356, Feb. 2013.
- [110] R. T. Pinto, P. Bauer, S. F. Rodrigues, E. J. Wiggelinkhuizen, J. Pierik, and B. Ferreira, "A novel distributed direct-voltage control strategy for grid integration of offshore wind energy systems through MTDC Network," *IEEE Trans. Ind. Electron.*, vol. 60, no. 6, pp. 2429–2441, Jun. 2013.
- [111] C. Gavriluta, I. J. Candela, C. Citro, J. Rocabert, and P. Rodriguez, "Decentralized primary control of MTDC networks with energy storage and distributed generation," *IEEE Trans. Ind. Appl.*, vol. 50, no. 6, pp. 4122–4131, Nov./Dec. 2014.
- [112] X. Liu, P. Wang, and P. C. Loh, "A hybrid AC/DC microgrid and its coordination control," *IEEE Trans. Smart Grid*, vol. 2, no. 2, pp. 278–286, Jun. 2011.
- [113] R. Majumder, "A Hybrid microgrid with DC connection at back to back converters," *IEEE Trans. Smart Grid*, vol. 5, no. 1, pp. 251–259, Jan. 2014.
- [114] Z. Ye, "Modeling and control of parallel three-phase PWM converters," Ph.D. dissertation, Electr. Comput. Eng. Dept., Virginia Polytechnic Institute, Blacksburg, VA, USA, 2000.
- [115] P. C. Loh, D. Li, Y. K. Chai, and F. Blaabjerg, "Autonomous operation of hybrid microgrid with AC and DC subgrids," *IEEE Trans. Power Electron.*, vol. 28, no. 5, pp. 2214–2223, May 2013.
- [116] X. Lu, J. M. Guerrero, K. Sun, J. C. Vasquez, R. Teodorescu, and L. Huang, "Hierarchical control of parallel AC-DC converter interfaces for hybrid microgrids," *IEEE Trans. Smart Grid*, vol. 5, no. 2, pp. 683–692, Feb. 2014.
- [117] Z. Jiang and X. Yu, "Hybrid DC- and AC-linked microgrids: Towards integration of distributed energy resources," in *Proc. IEEE Energy 2030 Conf.*, 2008, pp. 1–8.
- [118] A. A. A. Radwan and Y. A. I. Mohamed, "Assessment and mitigation of interaction dynamics in hybrid AC/DC distribution generation systems," *IEEE Trans. Smart Grid*, vol. 3, no. 3, pp. 1382–1393, Sep. 2012.
- [119] N. Flourentzou, V. G. Agelidis, and G. D. Demetriades, "VSC-based HVDC power transmission systems: An overview," *IEEE Trans. Power Electron.*, vol. 24, no. 3, pp. 592–602, Mar. 2009.
- [120] M. Bragard, N. Soltan, S. Thomas, and R. W. De Doncker, "The balance of renewable sources and user demands in grids: power electronics for modular battery energy storage systems," *IEEE Trans. Power Electron.*, vol. 25, no. 12, pp. 3049–3056, Dec. 2010.
- [121] N. Hatzigiorgiou, H. Asano, R. Iravani, and C. Marnay, "Microgrids," *IEEE Power Energy Mag.*, vol. 5, no. 4, pp. 78–94, Jul./Aug. 2007.
- [122] G. Venkataramanan and C. Marnay, "A larger role for microgrids," *IEEE Power Energy Mag.*, vol. 6, no. 3, pp. 78–82, May/Jun. 2008.
- [123] M. Cespedes, L. Xing, and J. Sun, "Constant-power load system stabilization by passive damping," *IEEE Trans. Power Electron.*, vol. 26, no. 7, pp. 1832–1836, Jul. 2011.
- [124] A. M. Rahimi and A. Emadi, "Active damping in DC/DC power electronic converters: A novel method to overcome the problems of constant power loads," *IEEE Trans. Ind. Electron.*, vol. 56, no. 5, pp. 1428–1439, May 2009.
- [125] O. Garcia, P. Zumel, A. de Castro, and J. A. Cobos, "Automotive DC-DC bidirectional converter made with many interleaved buck stages," *IEEE Trans. Power Electron.*, vol. 21, no. 3, pp. 578–586, May 2006.
- [126] J. Johnston, J. Counsell, G. Banks, and M. J. Stewart, "Beyond power over Ethernet: The development of digital energy networks for buildings," presented at the CIBSE Technical Symp., London, U.K., 2012.
- [127] M.-H. Ryu, H.-S. Kim, J.-H. Kim, J.-W. Baek, and J.-H. Jung, "Test bed implementation of 380V DC distribution system using isolated bidirectional power converters," in *Proc. IEEE Energy Convers. Congr. Expo.*, 2013, pp. 2948–2954.
- [128] Intelligent DC microgrid living lab. (2014). [Online]. Available: <http://www.et.aau.dk/research-programmes/microgrids/activities/intelligent-dc-microgrid-living-lab/>
- [129] D. J. Becker and B. J. Sonnenberg, "DC microgrids in buildings and data centers," in *Proc. IEEE Int. Telecommun. Energy Conf.*, 2011, pp. 1–7.
- [130] Smart grid strategy: The intelligent energy system of the future, Danish ministry of climate, energy building. (2013). [Online]. Available: [http://www.ens.dk/sites/ens.dk/files/undergrund-forsyning/el-naturgas-varmeforsyning/Smart-grid/smartgridstrategy\\_uk\\_web.pdf](http://www.ens.dk/sites/ens.dk/files/undergrund-forsyning/el-naturgas-varmeforsyning/Smart-grid/smartgridstrategy_uk_web.pdf)
- [131] (2009). Smart grid: An introduction, the U.S. department of energy. [Online]. Available: <http://energy.gov/oe/downloads/smart-grid-introduction-0>
- [132] A.-H. Mohsenian-Rad, V. W. S. Wong, J. Jatskevich, R. Schober, and A. Leon-Garcia, "Autonomous demand-side management based on game-theoretic energy consumption scheduling for the future smart grid," *IEEE Trans. Smart Grid*, vol. 1, no. 3, pp. 320–331, Dec. 2010.
- [133] D. Guezgouz, D. E. Chariag, Y. Raingeaud, and J.-C. Le Bunetel, "Modeling of electromagnetic interference and PLC transmission for loads shedding in a microgrid," *IEEE Trans. Power Electron.*, vol. 26, no. 3, pp. 747–754, Mar. 2011.
- [134] A.-H. Mohsenian-Rad and A. Leon-Garcia, "Optimal residential load control with price prediction in real-time electricity pricing environments," *IEEE Trans. Smart Grid*, vol. 1, no. 2, pp. 120–133, Sep. 2010.
- [135] P. Du and N. Lu, "Appliance commitment for household load scheduling," *IEEE Trans. Smart Grid*, vol. 2, no. 2, pp. 411–419, Jun. 2011.
- [136] H. Saele and O. S. Grande, "Demand response from household customers: Experiences from a pilot study in Norway," *IEEE Trans. Smart Grid*, vol. 2, no. 1, pp. 102–109, Mar. 2011.
- [137] X. Chen, T. Wei, and S. Hu, "Uncertainty-aware household appliance scheduling considering dynamic electricity pricing in smart home," *IEEE Trans. Smart Grid*, vol. 4, no. 2, pp. 932–941, Jun. 2013.

- [138] M. Sechilariu, B. Wang, and F. Locment, "Building-integrated microgrid: Advanced local energy management for forthcoming smart power grid communication," *Energy Build.*, vol. 59, pp. 236–243, 2013.
- [139] H. Kakigano, Y. Miura, and T. Ise, "Distribution voltage control for DC microgrids using fuzzy control and gain-scheduling technique," *IEEE Trans. Power Electron.*, vol. 28, no. 5, pp. 2246–2258, May 2013.
- [140] K. Tanaka, K. Uchida, M. Oshiro, T. Goya, T. Senjyu, and A. Yona, "Optimal operation for DC smart houses considering forecasted error," in *Proc. Int. Power Electron. Conf.*, 2010, pp. 722–727.
- [141] H. A. B. Siddique, S. M. Ali, and R. W. De Doncker, "DC collector grid configurations for large photovoltaic parks," in *Proc. Eur. Conf. Power Electron. Appl.*, 2013, pp. 1–10.
- [142] S. Chuangpishit, A. Tabesh, Z. Moradi-Sharbabk, and M. Saeedifard, "Topology design for collector systems of offshore wind farms with pure DC power systems," *IEEE Trans. Ind. Electron.*, vol. 61, no. 1, pp. 320–328, Jan. 2014.
- [143] B.-I. Craciun, T. Kerekes, D. Sera, and R. Teodorescu, "Overview of recent grid codes for PV power integration," in *Proc. Int. Conf. Opt. Electr. Electron. Equip.*, 2012, pp. 959–965.
- [144] M. Tili and S. Papathanassiou, "A review of grid code technical requirements for wind farms," *IET Renew. Power Gener.*, vol. 3, no. 3, pp. 308–332, 2009.
- [145] A. Mohamed and O. Mohammed, "Real-time energy management scheme for hybrid renewable energy systems in smart grid applications," *Electr. Power Syst. Res.*, vol. 96, pp. 133–143, 2013.
- [146] C. Chen, S. Duan, T. Cai, B. Liu, and G. Hu, "Optimal allocation and economic analysis of energy storage system in microgrids," *IEEE Trans. Power Electron.*, vol. 26, no. 10, pp. 2762–2773, Oct. 2011.
- [147] T.-F. Wu, C.-H. Chang, L.-C. Lin, and Y.-L. Lin, "Power loss analysis of photovoltaic DC distributed generation systems with grid-connection," in *Proc. IEEE Int. Conf. Power Electron.*, 2011, pp. 2344–2351.
- [148] S. Lundberg, "Wind farm configuration and energy efficiency studies-series DC versus AC layouts," Ph.D. dissertation, Dept. Energy Environ., Chalmers Univ. Technol., Göteborg, Sweden, 2006.
- [149] S. Vazquez, S. M. Lukic, E. Galvan, L. G. Franquelo, and J. M. Carrasco, "Energy storage system for transport and grid application," *IEEE Trans. Ind. Electron.*, vol. 57, no. 12, pp. 3881–3895, Dec. 2010.
- [150] Y. Wang, X. Lin, Q. Xie, N. Chang, and M. Pedram, "Minimizing state-of-health degradation in hybrid electrical energy storage systems with arbitrary source and load profiles," in *Proc. Des., Autom. Test Eur. Conf. Exhib.*, 2014, pp. 1–4.
- [151] T. Dragicevic, H. Pandzic, D. Skrlec, I. Kuzle, J. Guerrero, and D. Kirschen, "Capacity optimization of renewable energy sources and battery storage in an autonomous telecommunication facility," *IEEE Trans. Sustain. Energy*, vol. 5, no. 4, pp. 1367–1378, Oct. 2014.
- [152] S. Lemofouet and A. Rufer, "A hybrid energy storage system based on compressed air and supercapacitors with maximum efficiency point tracking (MEPT)," *IEEE Trans. Ind. Electron.*, vol. 53, no. 4, pp. 1105–1115, Jun. 2006.
- [153] A. Ravichandran, P. Malysz, S. Sirouspour, and A. Emadi, "The critical role of microgrids in transition to a smarter grid: A technical review," in *Proc. IEEE Transp. Electr. Conf. Expo.*, 2013, pp. 1–7.
- [154] P. J. Tulpule, V. Marano, S. Yurkovich, and G. Rizzoni, "Economic and environmental impacts of a PV powered workplace parking garage charging station," *Appl. Energy*, vol. 108, pp. 323–332, 2013.
- [155] H. Choi, M. Ciobotaru, M. Jang, and V. G. Agelidis, "Performance of medium-voltage DC-bus PV system architecture utilizing high-gain DC-DC converter," *IEEE Trans. Sustain. Energy*, vol. 6, no. 2, pp. 464–473, Apr. 2015.
- [156] V. Yaramasu, B. Wu, P. C. Sen, S. Kouro, and M. Narimani, "High-power wind energy conversion systems: State-of-the-art and emerging technologies," *Proc. IEEE*, vol. 103, no. 5, pp. 740–788, May 2015.
- [157] T. Kerekes, E. Koutroulis, D. Sera, R. Teodorescu, and M. Katsanevakis, "An optimization method for designing large PV plants," *IEEE J. Photovoltaics*, vol. 3, no. 2, pp. 814–822, Apr. 2013.
- [158] P. Garcia, L. M. Fernandez, C. A. Garcia, and F. Jurado, "Energy management system of fuel-cell-battery hybrid tramway," *IEEE Trans. Ind. Electron.*, vol. 57, no. 12, pp. 4013–4023, Dec. 2010.
- [159] X. Wang, M. Yue, E. Muljadi, and W. Gao, "Probabilistic approach for power capacity specification of wind energy storage systems," *IEEE Trans. Ind. Appl.*, vol. 50, no. 2, pp. 1215–1224, Mar. 2014.
- [160] P. Wang, J. Xiao, and L. Setyawan, "Hierarchical control of hybrid energy storage system in DC microgrids," *IEEE Trans. Ind. Electron.*, vol. 62, no. 8, pp. 4915–4924, Aug. 2015.
- [161] G. F. Reed, B. M. Grainger, A. R. Sparacino, R. J. Kerestes, and M. J. Korytowski, "Advancements in medium voltage DC architecture development with applications for powering electric vehicle charging stations," in *Proc. IEEE Energytech*, 2012, pp. 1–8.
- [162] M. Vasiladiotis and A. Rufer, "A modular multiport power electronic transformer with integrated split battery energy storage for versatile ultrafast EV charging stations," *IEEE Trans. Ind. Electron.*, vol. 62, no. 5, pp. 3213–3222, May 2015.
- [163] L. Tan, B. Wu, S. Rivera, and V. Yaramasu, "Comprehensive DC power balance management in high-power three-level DC-DC converter for electric vehicle fast charging," *IEEE Trans. Power Electron.*, 2015, to be published.
- [164] J. Yang, J. E. Fletcher, and J. O'Reilly, "Short-circuit and ground fault analyses and location in VSC-based DC network cables," *IEEE Trans. Ind. Electron.*, vol. 59, no. 10, pp. 3827–3837, Oct. 2012.
- [165] B. Ram, *Power System Protection and Switchgear*. New York, NY, USA: McGraw-Hill, 2011.
- [166] A. Berizzi, A. Silvestri, D. Zaninelli, and S. Massucco, "Short-circuit current calculations for DC systems," *IEEE Trans. Ind. Appl.*, vol. 32, no. 5, pp. 990–997, Sep./Oct. 1996.
- [167] D. Paul, "DC traction power system grounding," *IEEE Trans. Ind. Appl.*, vol. 38, no. 3, pp. 818–824, Jun. 2002.
- [168] S. A. Memon and P. Fromme, "Stray current corrosion and mitigation: A synopsis of the technical methods used in dc transit systems," *IEEE Electr. Mag.*, vol. 2, no. 3, pp. 22–31, Sep. 2014.
- [169] I. Cotton, C. Charalambous, P. Aylott, and P. Ernst, "Stray current control in DC mass transit systems," *IEEE Trans. Veh. Technol.*, vol. 54, no. 2, pp. 722–730, Mar. 2005.
- [170] J.-M. Shen, H.-L. Jou, and J.-C. Wu, "Novel transformerless grid-connected power converter with negative grounding for photovoltaic generation system," *IEEE Trans. Power Electron.*, vol. 27, no. 4, pp. 1818–1829, Apr. 2012.
- [171] C. Charalambous, N. Kokkinos, and A. Demetriou, "Impact of photovoltaic oriented DC stray current corrosion on large scale solar farms' grounding and third-party infrastructure: modelling and assessment," *IEEE Trans. Ind. Appl.*, 2015, to be published.
- [172] O. Lopez, F. D. Freijedo, A. G. Yepes, P. Fernandez-Comesaa, J. Malvar, R. Teodorescu, and J. Doval-Gandoy, "Eliminating ground current in a transformerless photovoltaic application," *IEEE Trans. Energy Convers.*, vol. 25, no. 1, pp. 140–147, Mar. 2010.
- [173] M. E. Baran and N. R. Mahajan, "DC distribution for industrial systems: Opportunities and challenges," *IEEE Trans. Ind. Appl.*, vol. 39, no. 6, pp. 1596–1601, Nov./Dec. 2003.
- [174] J. Park, "Ground fault detection and location for ungrounded DC traction power systems," *IEEE Trans. Veh. Technol.*, 2015, to be published.
- [175] M. Valdes, T. Papallo, and B. Premerlani, "Finding fault—Locating a ground fault in low-voltage, high-resistance grounded systems via the single-processor concept for circuit protection," *IEEE Ind. Appl. Mag.*, vol. 13, no. 5, pp. 24–30, Sep. 2007.
- [176] B. Jacobson and J. Walker, "Grounding considerations for DC and mixed DC and AC power systems," *Nav. Eng. J.*, vol. 119, no. 2, pp. 49–62, 2007.
- [177] *IEC 60364-1 Low-Voltage Electrical Installations—Part 1: Fundamental Principles, Assessment of General Characteristics, Definitions*, IEC 60364-1, 2005.
- [178] C.-H. Lee and C.-J. Lu, "Assessment of grounding schemes on rail potential and stray currents in a DC transit system," *IEEE Trans. Power Del.*, vol. 21, no. 4, pp. 1941–1947, Oct. 2006.
- [179] J.-M. Meyer and A. Rufer, "A DC hybrid circuit breaker with ultra-fast contact opening and integrated gate-commutated thyristors (IGCTs)," *IEEE Trans. Power Del.*, vol. 21, no. 2, pp. 646–651, Apr. 2006.
- [180] *IEEE Guide for the Protection of Stationary Battery Systems*, IEEE Std 1375-1998, 1998.
- [181] C. Meyer, S. Schroder, and R. W. De Doncker, "Solid-state circuit breakers and current limiters for medium-voltage systems having distributed power systems," *IEEE Trans. Power Electron.*, vol. 19, no. 5, pp. 1333–1340, Sep. 2004.
- [182] D. Lawes, L. Ran, and Z. Xu, "Design of a solid-state DC circuit breaker for light rail transit power supply network," in *Proc. IEEE Energy Convers. Congr. Expo.*, 2014, pp. 350–357.

- [183] S. Krstić, E. L. Wellner, A. R. Bendre, and B. Semenov, "Circuit breaker technologies for advanced ship power systems," in *Proc. IEEE Electr. Ship Technol. Symp.*, 2007, pp. 201–208.
- [184] Z. J. Shen, G. Sabui, Z. Miao, and Z. Shuai, "Wide-bandgap solid-state circuit breakers for DC power systems: Device and circuit considerations," *IEEE Trans. Electron Devices*, vol. 62, no. 2, pp. 294–300, Feb. 2015.
- [185] J. Jebramcik and F. Berger, "Observations on switching characteristics of arc chutes in DC contactors," in *Proc. Int. Conf. Electr. Contacts*, 2014, pp. 1–6.
- [186] C. Jin and R. Dougal, "Current limiting technique based protection strategy for an industrial DC distribution system," in *Proc. IEEE Int. Symp. Ind. Electron.*, 2006, vol. 2, pp. 820–825.
- [187] F. Luo, J. Chen, X. Lin, Y. Kang, and S. Duan, "A novel solid state fault current limiter for DC power distribution network," in *Proc. IEEE Appl. Power Electron. Conf. Expo.*, 2008, pp. 1284–1289.
- [188] K. Yasuda, A. Ichinose, A. Kimura, K. Inoue, H. Morii, Y. Tokunaga, S. Torii, T. Yazawa, S. Hahakura, K. Shimohata, and H. Kubota, "Research development of superconducting fault current limiter in Japan," *IEEE Trans. Appl. Supercond.*, vol. 15, no. 2, pp. 1978–1981, Jun. 2005.
- [189] M. E. Baran and N. R. Mahajan, "Overcurrent protection on voltage-source-converter-based multiterminal DC distribution systems," *IEEE Trans. Power Del.*, vol. 22, no. 1, pp. 406–412, Jan. 2007.
- [190] ETSI EN 300 132-3-1. (2011). [Online]. Available: [http://www.etsi.org/deliver/etsi\\_en/300100\\_300199/3001320301/02.01.01\\_40/en\\_3001320301v020101o.pdf](http://www.etsi.org/deliver/etsi_en/300100_300199/3001320301/02.01.01_40/en_3001320301v020101o.pdf)
- [191] *EMerge Alliance Standards*. (2008). [Online]. Available: <http://www.emergealliance.org/Standards/OurStandards.aspx>
- [192] *IEEE Recommended Practice for the Design of DC Auxiliary Power Systems for Generating Stations*, IEEE Std 946-1992, pp. 1–35, Feb. 1993.
- [193] A. T. Elsayed, A. A. Mohamed, and O. A. Mohammed, "DC microgrids and distribution systems: An overview," *Electr. Power Syst. Res.*, vol. 119, pp. 407–417, 2015.
- [194] IEC—Standardization management board—SG4 LVDC distribution systems up to 1500V DC. (2009). [Online]. Available: [http://www.iec.ch/dyn/www/?p=103:85:0:::FSP\\_ORG\\_ID:6019](http://www.iec.ch/dyn/www/?p=103:85:0:::FSP_ORG_ID:6019)
- [195] DC in the home. (2013). [Online]. Available: [https://standards.ieee.org/about/sasb/iccom/IC13-005-02\\_DC\\_in\\_the\\_Home.pdf](https://standards.ieee.org/about/sasb/iccom/IC13-005-02_DC_in_the_Home.pdf)
- [196] MIL-STD-1399. (1992). [Online]. Available: [https://www.wbdg.org/ccb/FEDMIL/std1399\\_300b.pdf](https://www.wbdg.org/ccb/FEDMIL/std1399_300b.pdf)
- [197] E. Planas, J. Andreu, J. I. Gárate, I. M. de Alegría, and E. Ibarra, "AC and DC technology in microgrids: A review," *Renew. Sustain. Energy Rev.*, vol. 43, pp. 726–749, 2015.
- [198] *IEEE Application Guide for IEEE Std 1547(TM), IEEE Standard for Interconnecting Distributed Resources With Electric Power Systems*, IEEE Std 1547.2-2008, pp. 1–217, Apr. 2009.
- [199] J. Rekola, DC distribution and power electronics applications in smart grids. (2012). [Online]. Available: [http://webhotel2.tut.fi/units/set/opetus/kurssi/SET\\_1520/Materiaalit/2012/Jenni\\_DC-distribution.pdf](http://webhotel2.tut.fi/units/set/opetus/kurssi/SET_1520/Materiaalit/2012/Jenni_DC-distribution.pdf)



**Tomislav Dragičević** (S'09–M'13) received the M.E.E. and the industrial Ph.D. degrees from the Faculty of Electrical Engineering, Zagreb, Croatia, in 2009 and 2013, respectively.

He is currently a Postdoctoral Research Associate at the Institute of Energy Technology, Aalborg University, Aalborg, Denmark. His Ph.D. dissertation has been carried out in close cooperation with industry and he has received the highest honours for it. He has authored and coauthored more than 60 technical papers in his domain of interest, and 18 of them are

published in international journals. His current research interests include overall system design of autonomous and grid-connected dc and ac microgrids, and industrial application of advanced modeling, control and protection concepts to shipboard power systems, remote telecom stations, domestic and commercial facilities, and electric vehicle charging stations.

Dr. Dragičević is a Member of the IEEE Power Electronics and IEEE Power Systems Societies. He has served in Scientific Committee Boards in several IEEE conferences and has been invited for guest lectures and tutorials in a number of universities and companies around the world.

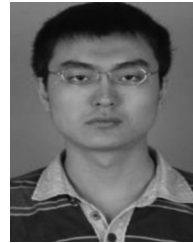

**Xiaonan Lu** (S'11–M'14) was born in Tianjin, China, in 1985. He received the B.E. and Ph.D. degrees in electrical engineering from Tsinghua University, Beijing, China, in 2008 and 2013, respectively.

From September 2010 to August 2011, he was a Guest Ph.D. Student at the Department of Energy Technology, Aalborg University, Aalborg, Denmark. From October 2013 to December 2014, he was a Postdoctoral Researcher with the Department of Electrical Engineering and Computer Science, University of Tennessee, Knoxville, TN, USA. In January 2015, he joined the Energy Systems Division, Argonne National Laboratory, Lemont, IL, USA, where he is currently a Postdoctoral Appointee. His research interests include modeling and control of power electronic converters in renewable energy systems and microgrids, hardware-in-the-loop real-time test, multilevel converters, matrix converters, etc.

Dr. Lu received the Outstanding Reviewer Award for the IEEE TRANSACTION ON POWER ELECTRONICS in 2014. He is a Member of the IEEE PELS IAS, and PES Societies.



**Juan C. Vasquez** (M'12–SM'14) received the B.S. degree in electronics engineering from the Autonomous University of Manizales, Manizales, Colombia, in 2004, and the Ph.D. degree in automatic control, robotics, and computer vision from the Technical University of Catalonia, Barcelona, Spain, in 2009.

He was with the Autonomous University of Manizales, where he taught courses on digital circuits, servo systems, and flexible manufacturing systems.

He was also with the Technical University of Catalonia, as a Postdoctoral Assistant, teaching courses based on renewable energy systems. In 2011, he was an Assistant Professor in microgrids. From February 2015 to April 2015, he was a Visiting Scholar at the Center of Power Electronics Systems at Virginia Tech. He is currently working as an Associate Professor at the Department of Energy Technology, Aalborg University, Aalborg, Denmark. He is coresponsible of the Research Program in Microgrids.

His current research interests include operation, power management, hierarchical control, optimization, and power quality applied to distributed generation and ac/dc microgrids. He is currently a Member of the IEC System Evaluation Group SEG4 on LVDC Distribution and Safety for use in Developed and Developing Economies and the Renewable Energy Systems Technical Committee TC-RES in the IEEE Industrial Electronics Society.



**Josep M. Guerrero** (S'01–M'04–SM'08–FM'15) received the B.S. degree in telecommunications engineering, the M.S. degree in electronics engineering, and the Ph.D. degree in power electronics from the Technical University of Catalonia, Barcelona, Spain, in 1997, 2000, and 2003, respectively.

Since 2011, he has been a Full Professor with the Department of Energy Technology, Aalborg University, Aalborg, Denmark, where he is responsible for the Microgrid Research Program, since 2012, he has been a Guest Professor at the Chinese Academy of

Science, Beijing, China, and the Nanjing University of Aeronautics and Astronautics, Nanjing, China; since 2014, he has been the Chair Professor at Shandong University, Shandong, China; and since 2015, he is a distinguished Guest Professor in Hunan University, Hunan, China.

His research interests include different microgrid aspects, including power electronics, distributed energy storage systems, hierarchical and cooperative controls, energy management systems, and optimization of microgrids and islanded minigrids.

Prof. Guerrero is an Associate Editor for the IEEE TRANSACTIONS ON POWER ELECTRONICS, the IEEE TRANSACTIONS ON INDUSTRIAL ELECTRONICS, and the IEEE INDUSTRIAL ELECTRONICS MAGAZINE, and an Editor for the IEEE TRANSACTIONS ON SMART GRID and the IEEE TRANSACTIONS ON ENERGY CONVERSION. He was the Chair of the Renewable Energy Systems Technical Committee of the IEEE Industrial Electronics Society. In 2014, he received the Highly Cited Researcher Award by Thomson Reuters.