

# Letters

## A DC-Link Modulation Scheme With Phase-Shifted Current Control for Harmonic Cancellations in Multidrive Applications

Yongheng Yang, *Member, IEEE*, Pooya Davari, *Member, IEEE*, Firuz Zare, *Senior Member, IEEE*, and Frede Blaabjerg, *Fellow, IEEE*

**Abstract**—This letter proposes a harmonic mitigation strategy to cancel out current harmonics induced by the front-end rectifiers in multidrive systems, which consist of diode rectifiers, silicon-controlled rectifiers (SCR), and boost converters in the dc-link. The proposed strategy is a combination of a new dc-link modulation scheme with a phase-shifted current control enabled by the SCR. The dc-link current modulation scheme is implemented by adding and subtracting specific modulation levels, which makes the total currents drawn from the grid “multilevel,” resulting in an improved current quality. Simulations and experiments have validated the effectiveness of the proposed harmonic mitigation solution for multidrive systems.

**Index Terms**—Adjustable speed drives, dc-link modulation, diode rectifier, harmonics, phase-shifted currents, silicon-controlled rectifier (SCR), three-phase multiple drive systems.

### I. INTRODUCTION

LOW-COST diode rectifiers and silicon-controlled rectifiers (SCR) are still very popular as the front-ends in modern adjustable speed drive systems [1], [2], as exemplified in Fig. 1. Harmonic emission and energy conversion efficiency are two major concerns for those drive systems [1]–[5]. Diode rectifiers and SCRs can achieve lower power losses, but increase the harmonics due to their high nonlinearity. Therefore, a vast array of harmonic mitigation solutions have been developed for such applications using either: 1) passive solutions (e.g., ac or dc chokes) that are suitable in low power applications, 2) multipulse transformer-based rectifiers as the front-ends [6], [7], 3) active power filtering techniques [8]–[10], and 4) hybrid solutions [11], [12]. Those harmonic mitigation strategies either increase the system overall volume or complicate the entire control system (or require auxiliary circuits), and thus, lead to increased cost, which is undesired in the drive systems.

In order to tackle these issues, a new dc-link current modulation scheme for multidrive systems is proposed in this letter. The new modulation scheme is derived by adding and subtracting specific modulation levels in such a way that the total

Manuscript received June 16, 2015; revised August 3, 2015; accepted August 23, 2015. Date of publication August 25, 2015; date of current version November 16, 2015.

Y. Yang, P. Davari, and F. Blaabjerg are with the Department of Energy Technology, Aalborg University, Aalborg DK-9220, Denmark (e-mail: yoy@et.aau.dk; pad@et.aau.dk; fbl@et.aau.dk).

F. Zare is with the Department of EMC and Harmonics, Global R&D Center, Danfoss Power Electronics A/S, Gråsten DK-6300, Denmark (e-mail: fza@danfoss.com).

Color versions of one or more of the figures in this paper are available online at <http://ieeexplore.ieee.org>.

Digital Object Identifier 10.1109/TPEL.2015.2472641

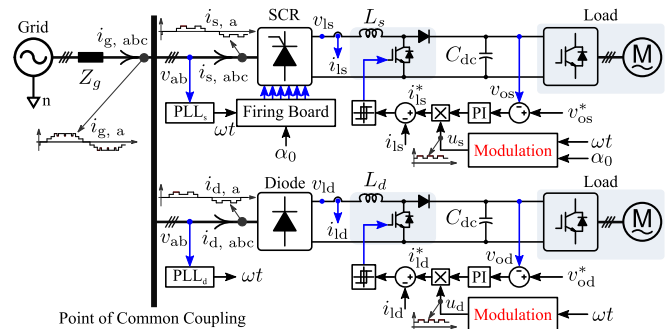

Fig. 1. Schematic and control structure of a multidrive system with boost converters as the dc-link, where hysteresis current controllers are employed: (PLL—Phase Locked Loop; PI—Proportional Integrator).

currents drawn by the rectifiers become “multilevel” [13], [14], leading to a mitigation of the current harmonics. Moreover, by phase-shifting the SCR currents, the grid current quality can be enhanced in terms of a lower total harmonic distortion (THD) and a mitigation of the harmonics of interest. If the modulation patterns are preprogrammed appropriately, the harmonic cancellation is enabled by a mix of the new modulation scheme and the phase-shifted current control, and it can be competitive to multipulse systems (e.g., 12-pulse diode rectifiers) [14]. In addition, an improvement of the harmonic cancellation strategy can be attained by optimizing the modulation patterns. Notably, one of the advantages of the proposal is to achieve low current THD even at partial power loading conditions in a cost- and size-effective way.

The rest of this letter is organized as follows. In Section II, the principle of the phase-shifted current control to mitigate the harmonics is introduced, followed by the new modulation scheme for the dc-link current. Simulations and experiments are carried out in order to verify the analysis. The results will demonstrate the effectiveness of the proposed dc-link modulation scheme with the phase-shifted current control in terms of harmonic cancellations in multidrive applications. In Section III, a basic comparison between the proposed solution with prior-art strategies is performed. Finally, conclusion is drawn in Section IV.

### II. PROPOSED DC-LINK MODULATION SCHEME

#### A. Phase-Shifted Current Control

According to Fig. 1, assuming that the dc-link current of the SCR unit  $i_{ls}$  (i.e., the rectified current) is controlled as a purely dc current (denoted as  $I_{ls}$ ), the currents  $i_{s,abc}$  drawn by the

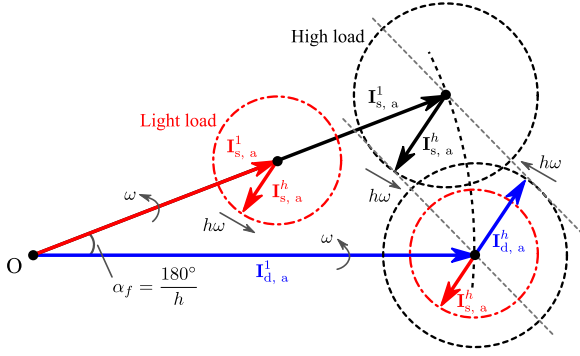

Fig. 2. Principle of harmonic cancellations by means of the phase-shifted current control in multidrive systems (phasor representations), where only the phasors of the fundamental phase-A currents (i.e.,  $I_{s,a}^1$  and  $I_{d,a}^1$ ) and the  $h$ -th harmonics (i.e.,  $I_{s,a}^h$  and  $I_{d,a}^h$ ) are shown.

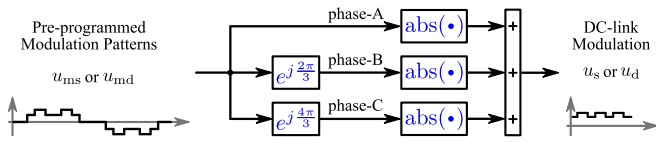

Fig. 3. Synthesis process of the proposed dc-link current modulation scheme for the drive systems shown in Fig. 1, where  $u_s$  and  $u_d$  are the synthesized dc-link current modulation signals.

SCR will be rectangular [15]. Taking the phase-A current as an example, it can be expressed by its Fourier series as

$$i_{s,a}(t) = \frac{2\sqrt{3}}{\pi} I_{Is} \sum_h \left\{ \frac{(-1)^n}{h} \sin[h(\omega t - \alpha_f)] \right\} \quad (1)$$

where  $h = 6n \pm 1$  is the harmonic order with  $h > 0$  and  $n = 0, 1, 2, \dots$ ,  $\omega t$  is defined to be zero at the positive zero crossing of the phase-A grid voltage  $v_{an}$  with  $\omega$  being the grid angular frequency, and  $\alpha_f \geq 0$  is the firing angle ( $\alpha_f = \alpha_0 - \pi/6$  in Fig. 1). Notably, the diode currents drawn from the grid (i.e.,  $i_{d,abc}$ ) can also be obtained from (1) by setting  $\alpha_f = 0$ .

Eq. (1) implies that the firing angle  $\alpha_f$  can control the phase of the currents drawn by the SCR  $i_{s,abc}$  and, thus, the output average voltage  $\bar{v}_{Is}$ . According to Fig. 1, combining the SCR and the diode rectifier offers a possibility to improve the grid current quality by properly phase-shifting the SCR currents, which in return can cancel out certain harmonics of the total currents drawn by the diode rectifier (i.e.,  $i_{d,abc}$ ). It can further be explained by Fig. 2, which exemplifies that the  $h$ -th harmonic can completely be eliminated by introducing a phase-shift of  $180^\circ/h$  to the SCR (i.e.,  $\alpha_f = 180^\circ/h$ ). This is valid only when the two rectifier systems are drawing the same amount of currents from the grid, being the main drawback of the phase-shifted current control.

### B. DC-Link Modulation Scheme

As mentioned above, when the rectifier output currents are controlled as dc currents, the currents drawn from the grid will be rectangular [15]. This will bring distortions to the grid, and even with the phase-shifted current control, only certain harmonics can be fully cancelled out in theory. In order to further reduce the harmonics, a dc-link modulation scheme is proposed, which will ensure that the currents drawn from the grid are “multilevel.” As shown in Fig. 3, the proposed scheme is synthesized using

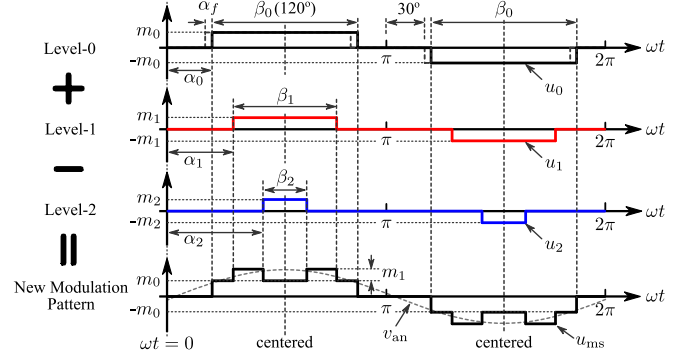

Fig. 4. Generation of the new preprogrammed modulation pattern in Fig. 3 (i.e., the desired phase-A current shape) for harmonic cancellations in a SCR-based drive system ( $\alpha_f = 0$  in the case of diode rectifiers), where  $m_0$ ,  $m_1$ , and  $m_2$  are modulation levels with  $m_1 = m_2$ .

preprogrammed modulation patterns (i.e., the desired phase-A current shape), and it is applicable to any single-drive system with a boost converter in the dc-link. Once the new modulation scheme (e.g.,  $u_s$  or  $u_d$ ) is employed in the dc-link (as the “Modulation” blocks in Fig. 1), the currents drawn by the rectifiers should follow the preprogrammed modulation patterns. Thus, the harmonic mitigations can be accomplished by properly designing the modulation patterns shown in Fig. 3. In this letter, a new modulation pattern has been designed by adding and subtracting specific modulation levels, as it is illustrated in Fig. 4, where the modulation patterns are centered and synchronized with respect to the phase-A grid voltage (i.e.,  $v_{an}$ ). The following demonstrates how harmonic mitigations are achieved in the SCR system by the designed modulation pattern shown in Fig. 4.

It is indicated in Fig. 4 that the preprogrammed modulation pattern  $u_{ms}$  consists of rectangular signals  $u_0$ ,  $u_1$ , and  $u_2$  with a conduction angle of  $\beta_0$  ( $120^\circ$ ),  $\beta_1$ , and  $\beta_2$  and a phase-shift of  $\alpha_0$ ,  $\alpha_1$ , and  $\alpha_2$ , correspondingly. Therefore, the  $h$ -th harmonic component of these rectangular signals (i.e.,  $u_0$ ,  $u_1$ , and  $u_2$ ) can be expressed as

$$u_i^h(t) = a_i^h \cos(h\omega t) + b_i^h \sin(h\omega t) \quad (2)$$

in which,  $i = 0, 1, 2$ , and  $h = 1, 3, 5, \dots$  is the harmonic order,  $a_i^h$  and  $b_i^h$  are the Fourier coefficients [15] that are given by

$$\begin{cases} a_i^h = \frac{2m_i}{h\pi} [-\sin(h\alpha_i) + \sin(h\alpha_i + h\beta_i)] \\ b_i^h = \frac{2m_i}{h\pi} [\cos(h\alpha_i) - \cos(h\alpha_i + h\beta_i)]. \end{cases} \quad (3)$$

Subsequently, according to the superposition principle and Fig. 4, the harmonic component  $u_{ms}^h$  of the new modulation pattern (i.e.,  $u_{ms}$ ) can be obtained as

$$\begin{aligned} u_{ms}^h(t) &= (a_0^h + a_1^h - a_2^h) \cos(h\omega t) \\ &\quad + (b_0^h + b_1^h - b_2^h) \sin(h\omega t) \end{aligned} \quad (4)$$

with its root-mean-square (rms) magnitude being

$$U_{ms}^h = \frac{\sqrt{2}}{2} \left[ (a_0^h + a_1^h - a_2^h)^2 + (b_0^h + b_1^h - b_2^h)^2 \right]^{1/2}. \quad (5)$$

By solving  $U_{ms}^h = 0$  ( $h \neq 1$ ) and  $U_{ms}^1 = M$  with  $M$  being the modulation index, harmonic cancellations can be achieved. When implemented according to Fig. 3, the currents drawn by

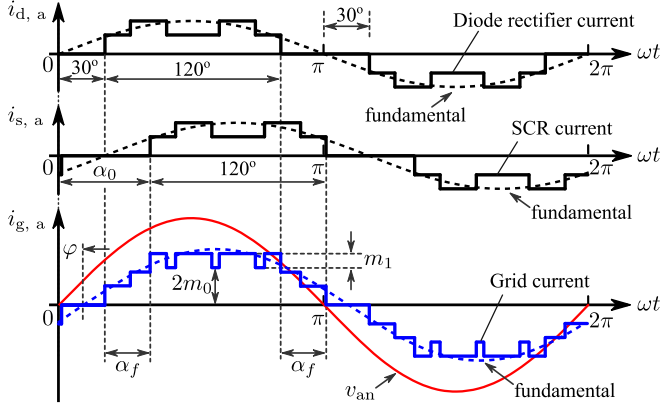

Fig. 5. Typical waveforms of the phase-A currents in a multidrive system (see Fig. 1) with the proposed modulation scheme and the phase-shifted control, where the current shapes follow the modulation pattern in Fig. 4.

the SCR will exactly follow the waveforms of the modulation pattern (e.g.,  $u_{ms}$ ). However, it should be noted that up to two low-order harmonics (e.g.,  $h = 5$  and  $h = 13$ ) in a single-drive system with a boost converter-based dc-link can be cancelled out by the new modulation scheme since the following conditions should be valid:

$$\begin{cases} \alpha_0 < \alpha_1 < \alpha_2 < \alpha_0 + 60^\circ \\ \beta_0 = \beta_1 + \beta_2 = 120^\circ \end{cases} \quad (6)$$

which may result in a unique solution of  $U_{ms}^h = 0$  ( $h \neq 1$ ) and  $U_{ms}^1 = M$ . It is worth mentioning that for diode rectifier systems, the new modulation pattern  $u_{md}$  can be obtained by setting  $\alpha_0 = 30^\circ$ . Doing so gives

$$u_{md}^h(t) = (c_0^h + c_1^h - c_2^h) \sin(h\omega t) \quad (7)$$

with  $u_{md}^h$  being the harmonics of the modulation pattern  $u_{md}$  for the diode rectifier system, and  $c_i^h$  ( $i = 0, 1, 2$ ) being the Fourier coefficients that can be expressed as

$$c_i^h = (-1)^k \frac{4m_i}{h\pi} \sin\left(\frac{h\beta_i}{2}\right) \quad (8)$$

where  $h = 2k + 1$  ( $k = 0, 1, 2, 3, \dots$ ) is the harmonic order.

Yet, it can be observed in Fig. 4 that the firing angle of a SCR (i.e.,  $\alpha_f$ ) is adjustable in the new modulation scheme. Therefore, for a multidrive system shown in Fig. 1, a further reduction of certain harmonics can be achieved as discussed in Section II-A (cf., Fig. 2) beyond the two low-order harmonics (e.g.,  $h = 5$  and  $h = 13$ ), which have been mitigated by the new dc-link modulation scheme [i.e.,  $U_{ms}^h = 0$  ( $h \neq 1$ ) and  $U_{ms}^1 = M$  according to (5)]. In that case, the resultant total harmonics  $u_{sum}^h$  will become

$$u_{sum}^h(t) = u_{ms}^h(t) + u_{md}^h(t). \quad (9)$$

Since  $i_g = i_s + i_d$ , the harmonics of the grid current will follow (9). Fig. 5 demonstrates the harmonic characteristics of the grid current  $i_g$  being multilevel with the proposed modulation scheme, which results in a better current quality. Notably, as it has been illustrated in Fig. 2, an assumption that the rectifiers are drawing the same amount of currents was made in Fig. 5. Nevertheless, a combination of the phase-shifted current control and the new modulation scheme can contribute to a lower THD of the grid currents in the multidrive systems.

TABLE I  
PARAMETERS OF THE MULTIDRIVE SYSTEM (SEE FIG. 1)

Parameter	Symbol	Value
Power rating	$P_n$	6 kW (total)
dc-link inductor	$L_s, L_d$	2 mH
dc-link capacitor	$C_{dc}$	470 $\mu$ F
Grid frequency	$f_g$	50 Hz
Grid phase voltage (RMS)	$v_{abc,n}$	220 V
Grid impedance	$Z_g (L_g, R_g)$	0.18 mH, 0.1 $\Omega$
PI controller	$k_p, k_i$	0.01, 0.1

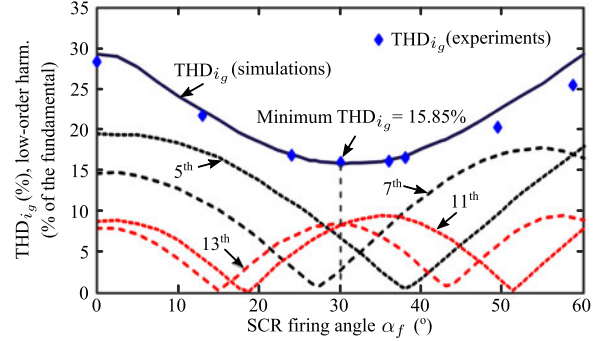

Fig. 6.  $THD_{i_g}$  and low-order harmonics of the grid current in the multidrive system with the phase-shifted current control.

It is also worth mentioning that: 1) the displacement power factor ( $\cos \varphi$ ) should be considered when applying the phase-shifted control, 2) optimizations in terms of minimizing the THD and/or lowering the harmonics of interest can be carried out according to (4), (7), and (9), 3) the flexibility of harmonic cancellations by the proposed method will be enhanced, if more SCR-based drives are included, and 4) load-adaptive strategies should be developed considering unbalanced loading conditions in practice. However, those are beyond the scope of this letter, which can be new research perspectives.

### III. SIMULATION AND EXPERIMENTAL RESULTS

In order to verify the effectiveness of the proposed modulation with the phase-shifted control, simulations and experiments have been done, referring to Figs. 1 and 3, where resistors are used as the loads. Hysteresis and PI controllers are selected to control the dc-link current ( $i_{ls}$  and  $i_{ld}$ ) and the output voltage ( $v_{os}$  and  $v_{od}$  with  $v_{os}^* = v_{od}^* = 700$  V), respectively. The system parameters are listed in Table I.

First, the phase-shifted current control is examined with only one modulation level (i.e.,  $u_0$  in Fig. 4). The results are presented in Fig. 6, showing that the  $THD_{i_g}$  can be reduced to some extent, when the phase-shifted current control is enabled (i.e.,  $\alpha_f \neq 0$ ). Moreover, the  $THD_{i_g}$  has been minimized to 15.85% at  $\alpha_f = 30^\circ$ . In addition, in order to cancel out an individual harmonic, the firing angle of the SCR unit has to be specified according to Fig. 6 (e.g.,  $36^\circ$  for cancelling out the fifth harmonic). The effectiveness of the phase-shifted current control is further confirmed by experimental results shown in Fig. 7(a). However, due to the presence of the grid impedance, the fifth harmonic is not fully eliminated [cf., Fig. 7(a)] by the phase-shifted control even when  $\alpha_f = 36^\circ$ . Nevertheless, the phase-shifted current control can reduce the harmonics, leading to a lower  $THD_{i_g}$ .

However, the one-level modulation pattern  $u_0$  with the phase-shifted current control can only lower the  $THD_{i_g}$  down

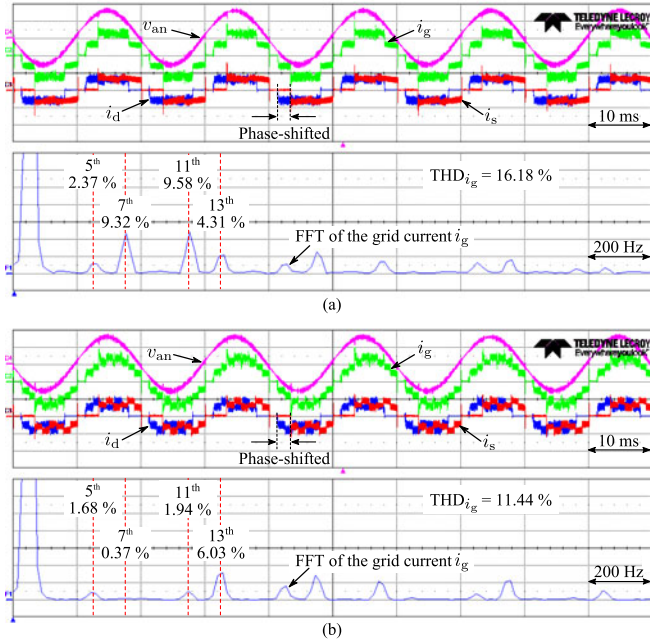

Fig. 7. Experimental results (phase-A) of the drive system with the phase-shifted current control (grid current  $i_g$  [10 A/div], grid voltage  $v_{an}$  [200 V/div], diode rectifier input current  $i_d$  [10 A/div], SCR input current  $i_s$  [10 A/div], and Fast Fourier Transform—FFT analysis [500 mA/div]): (a) with one-level modulation  $u_0$  ( $\alpha_f = 36^\circ$ ) and (b) with the proposed modulation.

TABLE II  
BENCHMARKING OF THE PROPOSED HARMONIC MITIGATION STRATEGY WITH PRIOR-ART SOLUTIONS [16], [17]<sup>1</sup>

Strategy	Typical THD	Complexity <sup>2</sup>	Cost <sup>3</sup>	Volume
Proposed solution	10%–12%	+	+	+
12-pulse rectifier	10%–15%	++	++	++
18-pulse rectifier	4%–7%	+++	+++	+++
Active filtering	3%–8%	+++	+++	++

Note: <sup>1</sup>The more “+,” the more complicated, the higher in cost, or the larger in volume (and also the heavier in weight);

<sup>2</sup>Include the implementation and control complexity;

<sup>3</sup>Not include the drive cost.

to 15.85%. Thus, the proposed dc-link modulation scheme is implemented according to Figs. 3 and 4, and applied to the drive system in order to further reduce the harmonics and, thus, the  $\text{THD}_{i_g}$ , where  $m_0 = 1$ ,  $m_1 = m_2 = 0.5326$ ,  $\alpha_0 = 66^\circ$  (for the SCR),  $\beta_1 = 80^\circ$ , and  $\beta_2 = 40^\circ$ . Fig. 7(b) shows the experimental results of the multidrive system using the dc-link modulation scheme with the phase-shifted current control. It can be seen that the  $\text{THD}_{i_g}$  of the grid current is significantly reduced to 11.44%. Moreover, the low-order harmonics (e.g., the 5th, 7th, and 11th harmonics) are also reduced. The above experiments have verified the effectiveness of the proposed modulation strategy (i.e., the dc-link modulation scheme with phase-shifted current control) in terms of harmonic cancellations in multidrive applications.

In addition, the proposed harmonic mitigation strategy is compared with the prior-art solutions [16], [17], as shown in Table II in terms of effectiveness in harmonic mitigations (typical resultant grid current THD), implementation and control complexity, cost, and volume. The basic benchmarking further highlights the merits of the proposal for harmonic cancellation in multidrive systems with boost converters in the dc-link. When

the unbalance loading issue is well addressed in practice, the proposed solution can be a cost-effective strategy for harmonic mitigations. It can compete with the 12-pulse rectifier in the harmonic performance.

#### IV. CONCLUSION

In this letter, a new dc-link modulation scheme aiming at harmonic mitigations has been proposed for three-phase multidrive systems with boost converters in the dc-link. This new modulation scheme has been implemented by adding and subtracting specific modulation levels, so that the currents drawn by the rectifiers are “multilevel.” Furthermore, an improved quality of the grid current has been achieved by combining the proposed modulation scheme with a phase-shifted current control in multidrive systems. The effectiveness of the proposed harmonic mitigation solution has been verified.

#### REFERENCES

- [1] J. W. Kolar and T. Friedli, “The essence of three-phase PFC rectifier systems: Part I,” *IEEE Trans. Power Electron.*, vol. 28, no. 1, pp. 176–198, Jan. 2013.
- [2] D. Kumar and F. Zare, “Harmonic analysis of grid connected power electronic systems in low voltage distribution networks,” *IEEE J. Emerg. Sel. Topics Power Electron.*, 10.1109/JESTPE.2015.2454537.
- [3] P. Waide and C. U. Brunner, “Energy-efficiency policy opportunities for electric motor-driven systems,” Tech. Rep., International Energy Agency, pp. 1–132, 2011.
- [4] T. Friedli, M. Hartmann, and J. W. Kolar, “The essence of three-phase PFC rectifier systems: Part II,” *IEEE Trans. Power Electron.*, vol. 29, no. 2, pp. 543–560, Feb. 2014.
- [5] P. K. Steimer, “High power electronics innovation,” in *Proc. 9th Int. Conf. Power Electron. ECCE Asia*, Jun. 2015, pp. 1–37.
- [6] S. Choi, P. N. Enjeti, and I. J. Pitel, “Polyphase transformer arrangements with reduced kVA capacities for harmonic current reduction in rectifier-type utility interface,” *IEEE Trans. Power Electron.*, vol. 11, no. 5, pp. 680–690, Sep. 1996.
- [7] F. Meng, W. Yang, Y. Zhu, L. Gao, and S. Yang, “Load adaptability of active harmonic reduction for 12-pulse diode bridge rectifier with active inter-phase reactor,” *IEEE Trans. Power Electron.*, vol. 30, no. 12, pp. 7170–7180, Dec. 2015.
- [8] H. Akagi, “Active harmonic filters,” *Proc. IEEE*, vol. 93, no. 12, pp. 2128–2141, Dec. 2005.
- [9] X. Du, L. Zhou, H. Lu, and H.-M. Tai, “DC link active power filter for three-phase diode rectifier,” *IEEE Trans. Ind. Electron.*, vol. 59, no. 3, pp. 1430–1442, Mar. 2012.
- [10] W.-J. Lee, Y. Son, and J.-I. Ha, “Single-phase active power filtering method using diode-rectifier-fed motor drive,” *IEEE Trans. Ind. Appl.*, vol. 51, no. 3, pp. 2227–2236, May/June 2015.
- [11] H. Akagi and K. Isozaki, “A hybrid active filter for a three-phase 12-pulse diode rectifier used as the front end of a medium-voltage motor drive,” *IEEE Trans. Power Electron.*, vol. 27, no. 1, pp. 69–77, Jan. 2012.
- [12] S. Hansen, P. Nielsen, and F. Blaabjerg, “Harmonic cancellation by mixing nonlinear single-phase and three-phase loads,” *IEEE Trans. Ind. Appl.*, vol. 36, no. 1, pp. 152–159, Jan./Feb. 2000.
- [13] F. Zare, “A novel harmonic elimination method for a three-phase diode rectifier with controlled DC link current,” in *Proc. 16th Int. Power Electron. Motion Control Conf.*, pp. 985–989, Sep. 21–24, 2014.
- [14] P. Davari, Y. Yang, F. Zare, and F. Blaabjerg, “A novel harmonic elimination approach in three-phase multi-motor drives,” in *Proc. 7th Annu. IEEE Energy Convers. Congress Expo.*, Sep. 20–24, 2015.
- [15] N. Mohan, T. M. Undeland, and W. P. Robbins, *Power Electronics: Converters, Applications, and Design*, 3rd ed. New York, NY, USA: Wiley, 2007, ch. 6 pp. 138–147.
- [16] Danfoss. (2015, Jul. 31). Comparing the Danfoss harmonic filter AHF 005 and AHF 010 with traditional multi-pulse solutions. [Online]. Available: <http://www.danfoss.com/NR/rdonlyres/6AE10CFE-58D6-41FB-B8AD-9430011E86E9/0/AHFcomparison.pdf>
- [17] D. J. Carnovale, T. J. Dionise, and T. M. Blooming. (2015, Jul. 31). Performance and price considerations for harmonic filtering solutions. [Online]. Available: <http://www.powerco.ca/wp-content/uploads/2011/11/14.pdf>